

MiCOM

series P10, series P20

Digital protection relays



Make the most of your energy

Range description

1

MiCOM series 10

2

MiCOM series 20

3

Order form

4

Maximize protection	6
Selection guide for all applications	10
Overcurrent applications	12
Feeder protection	12
Incomer protection	13
Transformer protection	14
Generator protection	17
Motor applications	19
Line differential applications	21
Voltage & Frequency applications	22
MiCOM Series 10	25
MiCOM series 20	99
Order form	187



1

Increase energy availability



Fast response

Maximum
dependability

Your electrical equipment is under control.
With MiCOM protection relays, you get
maximum energy availability for your process.

MiCOM protection relays

Number one in reliability

Maximize energy availability and the profits generated by your installation while protecting life and property.

The MiCOM range of relays offers varying levels of functionality and hardware options to best suit the protection requirements, and allows the customer to choose the most cost effective solution for their application.

The 10 and 20 series hardware platforms are the building blocks of the MiCOM protection relay range providing the capability for a wide variety of protection, control, measurement, monitoring and communication functions.

The versatile hardware allows for application in many installations and a common relay management software (MiCOM S1 Studio) makes for easy configuration and application.

A standard and simple user interface across the range makes this ideal in any environment, from the more complex bay level control and mimic to the more simple LCD display and interrogation facility.

Keep informed to manage better

With MiCOM, you get intuitive access to all system information in your language so that you can manage your electrical installation effectively. If a problem occurs, clear and complete information puts you in a position to make the right decisions immediately. The electrical supply is restored without delay.

Maintain installation availability

MiCOM maintains high energy availability thanks to its diagnostics function that continuously monitors network status.

In-depth analysis capabilities and high reliability ensure that equipment is de-energized only when absolutely necessary.

Risks are minimized and servicing time reduced by programming maintenance operations.

1999

Launch of first MiCOM relay protection

2014

Over 600,000 MiCOM units installed around the world

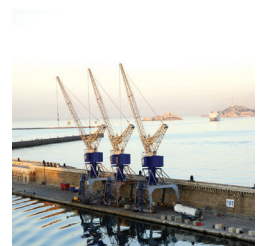

Electrical utilities, petrochemical plants, hospitals, small industry, infrastructures.

Operation



Setting file ready to be downloaded to MiCOM relay

download



export

Straightforward facility for commissioning

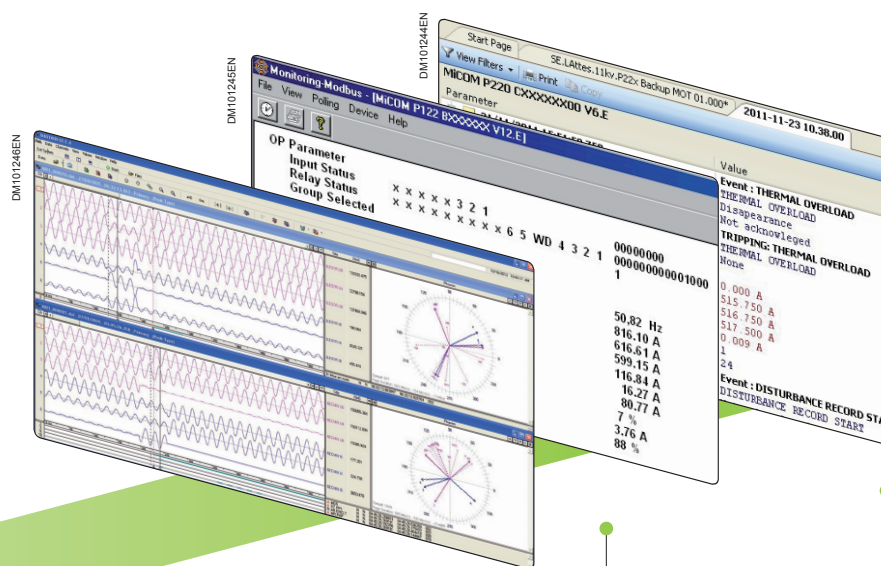

Analysis of waveform capture

Display, analysis and printing of disturbance records

Real-time supervision

Supervision of the status of all the relays in the electrical installation

Management of events

Display of event records in chronological order

Complete peace of mind during operation

1

The selection guide proposes the MiCOM types suited to your protection needs, based on the characteristics of your application. The most typical applications are presented with the corresponding MiCOM.

Each application example is described by:

- a single-line diagram indicating:
 - equipment to be protected
 - network configuration
 - position of measurement sensors
- standard and specific MiCOM functions to be implemented to protect the application.

The list of functions is given for information purposes. Earthing, wether direct or via an impedance, is represented by the same pictogram, i.e. the pictogram corresponding to a direct connection.

Warning: the MiCOM P911 is now rebranded as Vamp 11V. For further information please see Vamp documentation.

series 10

Page 24

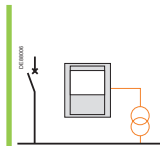
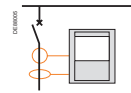

Protections

Current	■	■	■	
Voltage				■
Frequency				■
Specifics		self power	dual power	over / under voltage & frequency

Applications

Overcurrent

Feeder, Incomer, Transformer, Generator

P.12

Motor

P. 19

Line differential

P. 21

Voltage & Frequency

P. 22

P111

P115

P116

Vamp 11V

Characteristics

Logic inputs/outputs	Inputs	0 to 8	2	6	0 to 6
	Outputs	4 to 8	4	7	4 to 8
Temperature sensors	Channel				
	CT inputs	4	4	4	
Communication ports	VT inputs				4
		1	1	1	1
Control	Boolean logic equation	No			
Other	Withdrawable case	No	Yes	No	

series 20

Page 92

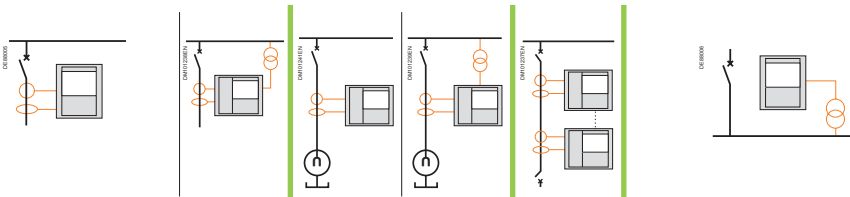

	■	■	■	■	■	■	■	■	■
			■	■	■	■	■	■	■
			■	■	■	■	■	■	■
		recloser	directional earth fault and phase overcurrent		over / under voltage	two ended current differential		over / under voltage & frequency	rate of change of frequency
	P122	P123	P127	P220	P225	P521	P921	P922	P923
	3	5	7 to 12	5	6	5	2	5	5
	7	9	9	6	6	9	4	8	8
				6	10				
	4	4	4	4	4	4			
			3		1	0	4	4	4
	1	1	1 to 2	1	1	1	1	1	1
					Yes				
					Yes				

1

Protection functions	ANSI code	P111	P115 CT powered or Dual powered	P116 CT powered or Dual powered	P122	P123	P127
Phase under/over voltage (AND & OR mode)	27/59						■
Directional Power (Under/Over act./react. power)	32						■
Wattmetric Earth Fault	32N/67W						■
Undercurrent / Loss of load	37			■	■	■	■
Negative phase sequence overcurrent	46	■ ⁽¹⁾		■	■	■	■
Broken conductor	46BC	■ ⁽¹⁾		■	■	■	■
Negative sequence overvoltage	47						■
Thermal overload	49	■ ⁽²⁾		■	■	■	■
Earth overcurrent / Sensitive earth fault	50N/51N	■	■	■	■	■	■
3 Phase overcurrent	50/51	■	■	■	■	■	■
Circuit breaker failure	50BF	■	■	■	■	■	■
Voltage controlled overcurrent	51V						■
Residual over voltage / Derived Vo sequence overvoltage	59N						■
Restricted earthfault	64	■			■	■	■
Earth fault directional overcurrent	67N						■
3 phase directional overcurrent	67P						■
Wattmetric earthfault	67W/32N						■
Autoreclose	79	■ ⁽³⁾		■		■	■
Under/over frequency	81O/U						■
Rate of change of Frequency (df/dt+)	81R						■
Output relay latching	86	■	■	■	■	■	■
CB command (local Open / Close)		■		■	■	■	■
Current transformer supervision	CTS						■
Switch on to fault	SOTF	■ ⁽⁴⁾		■		■	■
Trip Circuit Supervision	TCS	■ ⁽⁴⁾		■	■	■	■
Voltage transformer supervision	VTS/60						■
Circuit breaker monitoring		■ ⁽⁴⁾		■	■	■	■
Cold load pick-up	CLPU	■		■	■	■	■
Inrush blocking		■ ⁽⁴⁾		■	■	■	■

(1) Model E only
(2) Models E - A - B - N only
(3) Model E - A - B only
(4) Model A - E only

Feeder protection

Feeder protection

- Feeder short-circuit and overload protection.

Protection of low-capacitance feeders in impedance earthed or solidly earthed neutral systems: MiCOM P111, P115, P116, P122, P123 or P127

- no voltage and frequency monitoring

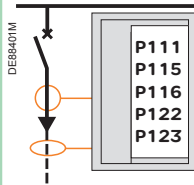

- voltage and frequency monitoring.

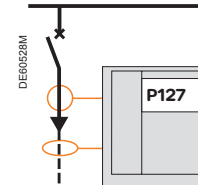

Protection of high-capacitance feeders in impedance earthed or compensated or isolated neutral systems: MiCOM P127

- Specific feeder protection: 67P/67N/67W.

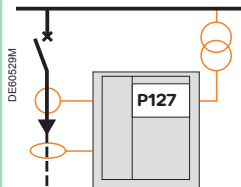

Incomer protection

Incomer protection

- Busbar short-circuit protection

Incomer protection: MiCOM P111, P115, P116, P122, P123 or P127

- No voltage and frequency monitoring

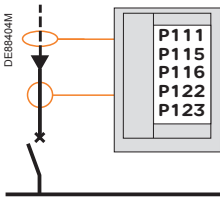

- Busbar voltage and frequency monitoring

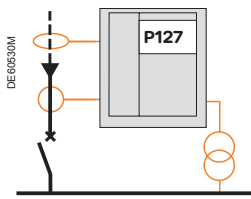

- Line voltage and frequency monitoring

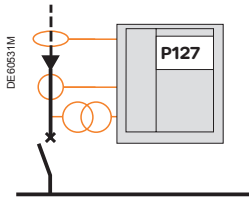

Protection of 2 incomers: MiCOM P127

- With automatic source transfer (ATS) without coupling

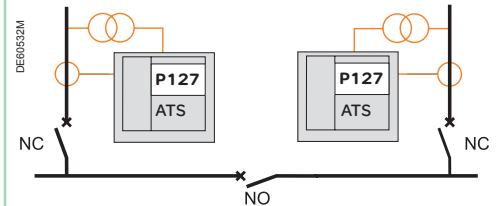

Parallel incomer protection: MiCOM P127

- Specific line or source protection: 67P, 67N/67W.

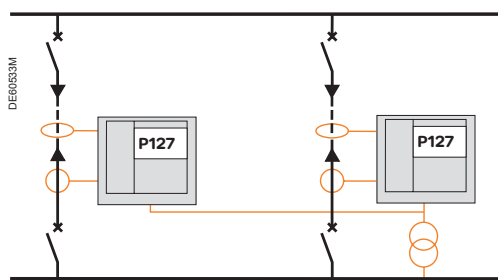

Parallel-incomer protection with disconnection function: MiCOM P127

- Disconnection-specific functions: 27, 32, 59, 59N, 81O/U

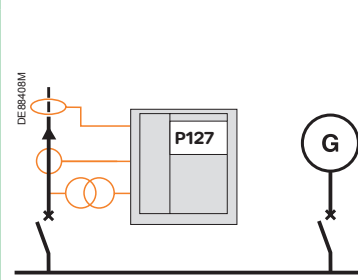

Protection of an incomer or coupling circuit breaker with load shedding based on frequency variations: MiCOM P127

- Load-shedding-specific functions: 81O/U

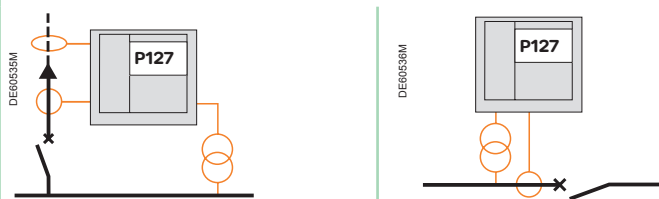

Ring incomer protection: MiCOM P127

- Line or source protection: 67P, 67N/67W
- Directional logic discrimination

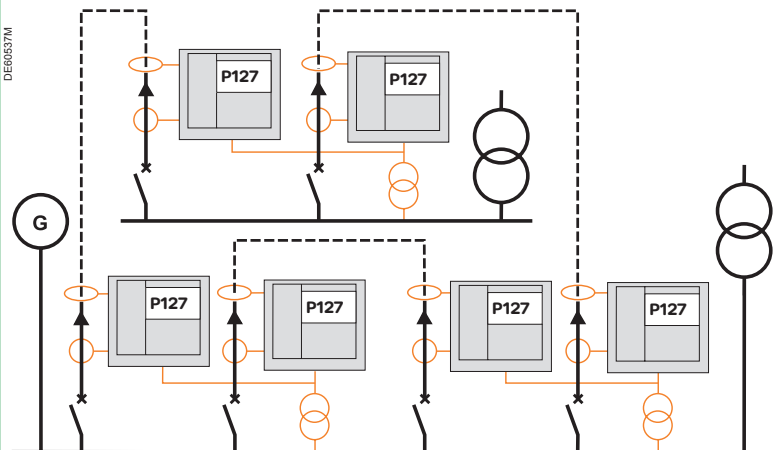

Transformer protection

Transformer feeder protection

- transformer short-circuit and overload protection
- internal transformer protection: Thermostat / Buchholz (ANSI 26/63) (*)
- RTD temperature monitoring (ANSI 49T) (*)

(*) Via logic inputs linked to devices integrated in the transformer

Transformer feeder protection without voltage monitoring: MiCOM P111, P116, P122, P123

- Earth fault protection:
- primary: 50N/51N

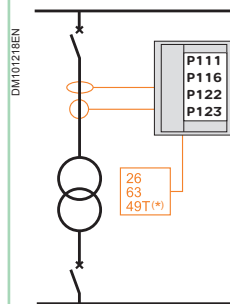

- Earth fault protection:
- neutral point: 50N/51N

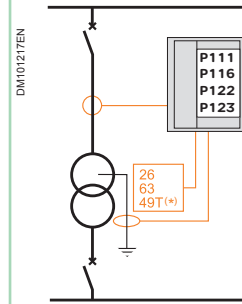

Transformer feeder protection with voltage monitoring: MiCOM P127

- Earth fault protection:
- primary: 50N/51N

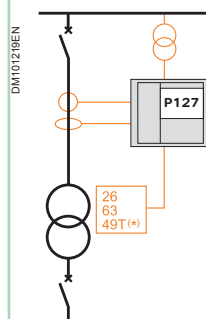

Note: for long feeders, the 50N/51N function may be replaced by the 67N

Transformer feeder protection with voltage monitoring and additional current measurement: MiCOM P127

- Earth fault protection:
- primary: 50N/51N
 - tank earth leakage: 50N/51N

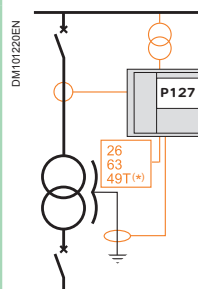

- Earth fault protection:
- primary: 50N/51N
 - secondary: 50N/51N

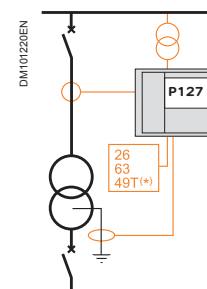

Note: for long feeders, the 50N/51N function may be replaced by the 67N

Transformer in-come protection

- transformer short-circuit and overload protection
- internal transformer protection: Thermostat / Buchholz (ANSI 26/63) (*)
- RTD temperature monitoring (ANSI 49T) (*)

(*) Via logic inputs linked to devices integrated in the transformer

Transformer in-come protection without voltage monitoring: MiCOM P111, P116, P122, P123

- Earth fault protection:
 ■ secondary: 50N/51N

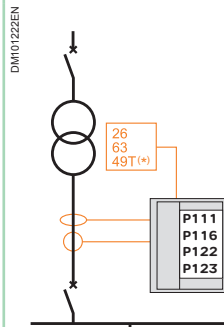

- Earth fault protection:
 ■ neutral point: 50N/51N

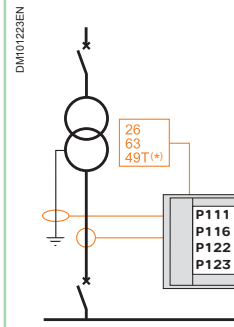

Transformer in-come protection with voltage monitoring: MiCOM P127

- Earth fault protection:
 ■ secondary: 50N/51N

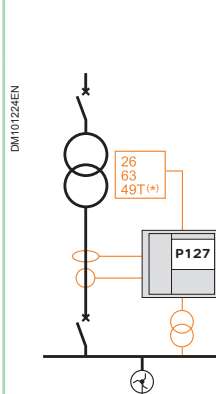

- Earth fault protection:
 ■ secondary:
 □ 64N
 □ 50N/51N

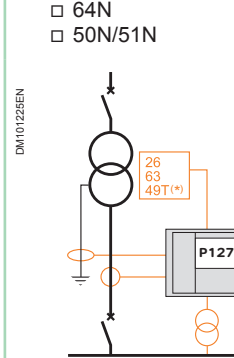

Note: for long feeders, the 50N/51N function may be replaced by the 67N

1

Transformer incomer protection

- transformer short-circuit and overload protection
- internal transformer protection: Thermostat / Buchholz (ANSI 26/63) (*)
- RTD temperature monitoring (ANSI 49T) (*)

(*) Via logic inputs linked to devices integrated in the transformer

Protection of 2 non-coupled transformers incomers: MiCOM P127

- automatic source transfer (ATS) without coupling

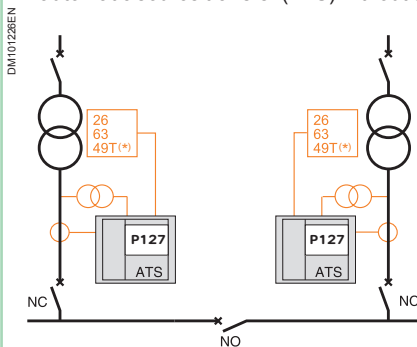

Parallel transformer incomer protection: MiCOM P127

- transformer directional phase overcurrent protection: 67
- transformer secondary earth fault protection: 50N/51N, 59N

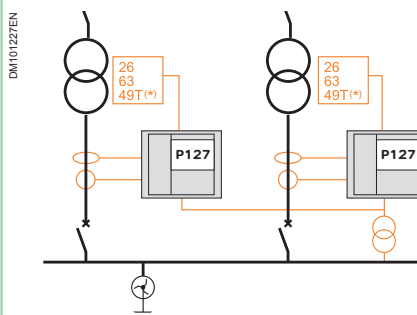

- transformer directional phase overcurrent protection: 67
- transformer secondary earth fault protection: 67N, 64N

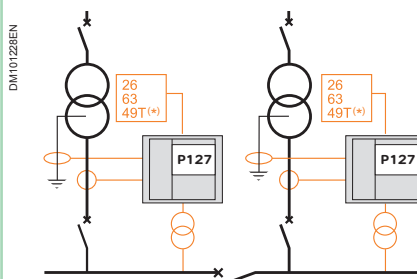

Generator protection

Generator-transformer unit protection

- generator and transformer protection against internal faults
- network fault protection
- driving machine fault protection
- RTD temperature monitoring (ANSI 38/49T) (*)
- voltage and frequency monitoring.

(*) Via logic inputs linked to devices integrated in the transformer

Protection of a separate generator: MiCOM P127

- Earth fault protection:
- 50N/51N
 - 59N

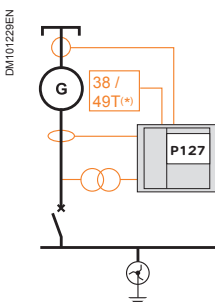

- Earth fault protection:
- 50N/51N

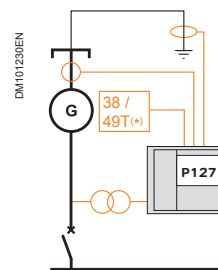

Protection of a generator-transformer unit coupled to other generators or to a network: MiCOM P127

- Short-circuit detection on generator side: 67
- Control fault protection

- Earth fault protection:
- 50N/51N
 - 59N

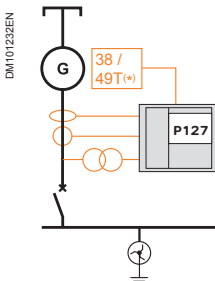

- Earth fault protection:
- 64 REF, 64N
 - 50N/51N

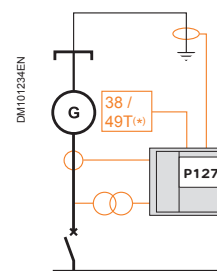

Protection functions	ANSI code	P220	P225
Speed switch inputs	12/14	■	■
Optional RTD	38/49T	6	10
Phase under/over voltage (AND & OR mode)	27/59		■
Re-acceleration autorisation	27LV		■
Undercurrent / Loss of load	37	■	■
Negative phase sequence overcurrent	46	■	■
Start / Stalled Protection / Motor Re-Acceleration	48/ 51LR	■	■
Thermal overload	49	■	■
Circuit breaker failure	50BF	■	■
3-Phase overcurrent	50 / 51	■	■
Earth overcurrent / Sensitive earth fault	50N / 51N	■	■
Locked Rotor during Start-up	51S	■	■
Number of Starts Limitation	66	■	■
Output relay latching	86	■	■
Trip Circuit Supervision	TCS	■	■

Motor protection

- internal motor fault protection
- power supply fault protection
- driven load fault protection
- RTD temperature monitoring (ANSI 38/49T)

Motor protection without voltage monitoring: MiCOM P220

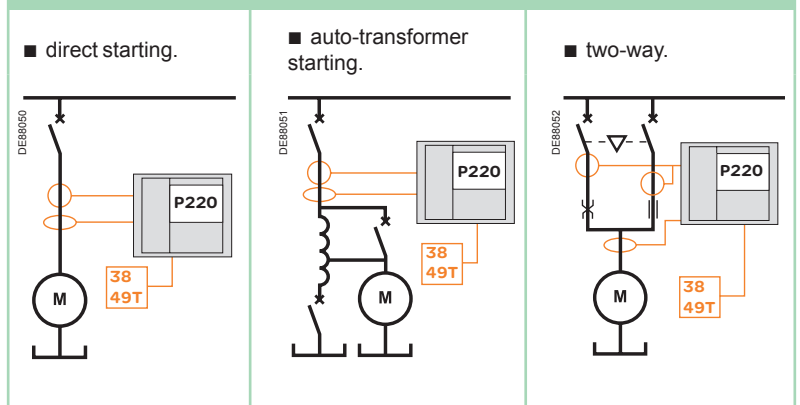

Motor protection with voltage monitoring: MiCOM P225

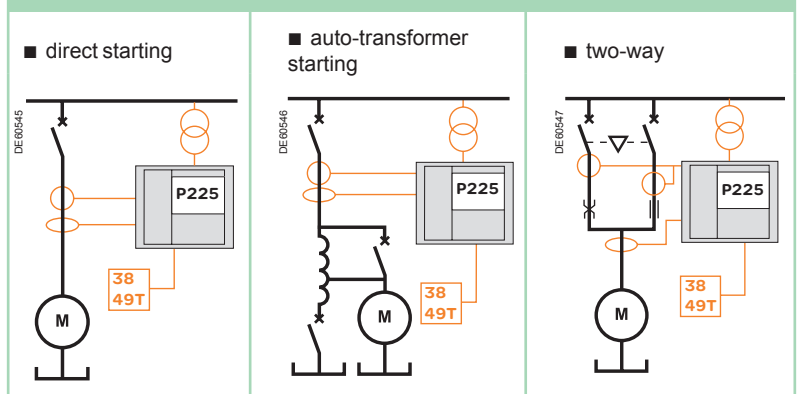

Motor-transformer unit protection

- motor and transformer protection against internal fault
- power supply fault protection
- driven load fault protection
- internal transformer protection: Thermostat / Buchholz (ANSI 26/63) (*)
- RTD temperature monitoring

(*) Via logic inputs linked to devices integrated in the transformer

Motor-transformer unit protection without voltage monitoring: MiCOM P220

- transformer primary earth fault protection: 50N/51N
- Note:** monitoring of motor insulation must be ensured by another device.

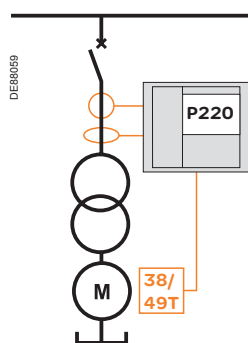

Motor-transformer unit protection with voltage and transformer monitoring: MiCOM P225 and P921 for neutral voltage protection

- motor earth fault protection: 59N
- transformer primary earth fault protection: 50N/51N
- transformer monitoring: Buchholz, thermostat, temperature measurement (*)

(*) Via logic inputs linked to devices integrated in the transformer

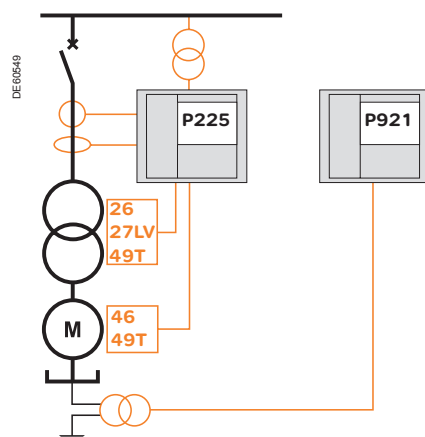

Protection functions	ANSI code	P521
Undercurrent detection	37	■
Negative phase sequence overcurrent	46	■
Broken conductor detection	46BC	■
Thermal overload	49	■
Circuit breaker failure	50BF	■
Non-directional phase overcurrent protection	50/51	■
Non-directional earth fault protection	50/51N	■
Output relay latching	86	■
Phase segregated current differential protection	87P	■
Current transformer supervision	CTS	■
Trip circuit supervision	TCS	■

Line differential protection

- Feeder protection

Differential monitoring: P521

- Phase segregated current differential protection: 86P

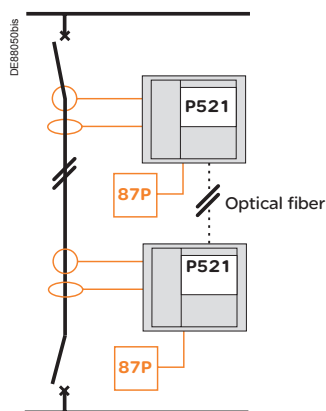

1

Protection functions	ANSI code	Vamp 11V ⁽¹⁾	P921	P922	P923
Phase under/over voltage (AND & OR mode)	27/59	■	■	■	■
Positive sequence under voltage	27D	■ ⁽²⁾		■	■
Negative sequence overvoltage	47	■ ⁽²⁾		■	■
Residual over voltage / Derived Vo sequence overvoltage	59N	■ ⁽³⁾	■	■	■
Voltage transformer supervision	VTS/ 60			■	■
Under/over frequency	81U/O	■ ⁽²⁾		■	■
Rate of change of Frequency (df/dt+t)	81R				■
Output relay latching	86	■	■	■	■

(1) Please consult Vamp 11V leaflet for details

(2) Model A only

(3) Model L has no residual voltage input.

59N is based on derived Vo sequence over voltage only

Voltage & frequency monitoring

- voltage and frequency monitoring

Monitoring of the 3 phase voltages and the residual voltage on busbars: MiCOM P921, P922, P923 and Vamp 11V

- load-shedding-specific function: 27/59

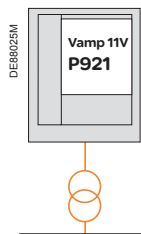

- load-shedding-specific functions: 81U/O

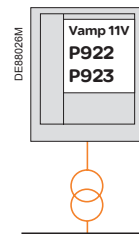

- change rate of frequency function: 81R

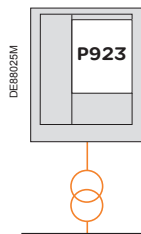

> TOOLS

schneider-electric.com

2

This international site allows you to access all the Schneider Electric products in just 2 clicks via comprehensive range data-sheets, with direct links to:

- complete library: technical documents, catalogs, FAQs, brochures...
- selection guides from the e-catalog.
- product discovery sites and their Flash animations.

You will also find illustrated overviews, news to which you can subscribe, the list of country contacts...

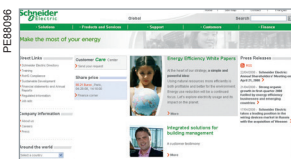

Automation panorama

This animated tool helps you to select the best Automation Intelligent Electronic Device adapted to your need. This CD includes description of all Schneider Electric IEDs ranges (Sepam, MiCOM, VAMP, Easergy). This selector is also included in the Schneider Electric web site.

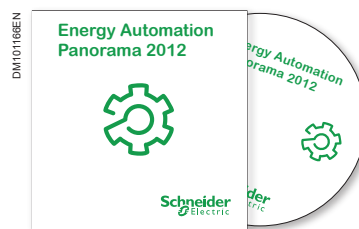

Range description	5
MiCOM series 10	25
Selection table	26
Sensor inputs	27
Environmental characteristics	28
MiCOM P111	30
Numerical three phase and earth fault overcurrent relay description	30
Ratings	31
Protection functions	34
Control & Monitoring	37
Setting ranges	39
Base unit	44
Presentation	44
Dimensions & weight	45
Description	46
Connection diagrams	47
MiCOM P115	52
Numerical CT and auxiliary voltage powered overcurrent relay description	52
Ratings	53
Protection functions	54
Control & Monitoring	59
Setting ranges	60
Base unit	64
Presentation	64
Dimensions & weight	65
Description	66
Connection diagrams	67
MiCOM P116	72
Numerical CT and Vx auxiliary voltage-powered overcurrent relay description	72
Ratings	73
Protection functions	76
Control & Monitoring	80
Setting ranges	82
Base unit	87
Presentation	87
Dimensions & weight	88
Description	89
Connection diagrams	90
MiCOM series 20	99
Order form	187

2

		Overcurrent						
Protection	ANSI	P111					P115 CT Powered or Dual Powered	P116 CT Powered or Dual Powered
		Model L	Model N	Model B	Model A	Model E		
Undercurrent	37							■
Negative sequence overcurrent	46					■		■
Broken conductor	46BC					■		■
Thermal overload	49		■	■	■	■		■
Circuit breaker failure	50BF	■	■	■	■	■	■	■
3 Phase overcurrent	50/51	■	■	■	■	■	■	■
Earth fault	50N/51N	■	■	■	■	■	■	■
Autoreclose	79					■		■
Lock-out	86	■	■	■	■	■	■	■
Inrush blocking					■	■		■
Switch on to fault	SOTF			■	■	■		■
Circuit breaker monitoring					■	■		■
Trip Circuit Supervision	TCS				■	■		■
Cold load pick-up		■	■	■	■	■		■

MiCOM series 10 sensor inputs, outputs

Each MiCOM series 10 has analog inputs that are connected to the measurement sensors required for the application.

	Overcurrent						
	P111					P115 CT Powered or Dual Powered	P116 CT Powered or Dual Powered
	Model L	Model N	Model B	Model A	Model E		
CT Inputs	4	4	4	4	4	4	4
Opto Inputs (max)			4	4	8	2	6
Output Contacts (max)	4	6	4	8	6	4	7
Output for Striker triggering /low energy 12-24Vdc CB coil/MiTOP						1	1
Magnetic Flags							up to 5
Communication port RS485: Modbus/IEC103	Option	1	1	1	1	1	1
USB Local Port		1	1	1	1	1	1

Insulation	Standard	Value
Insulation resistance	EN 60255-5: 2001	> 500 MΩ at 500 Vdc (Using only electronic/brushless insulation tester).
High Voltage (Dielectric) Withstand	EN 60255-27: 2005	2 kV rms AC, 1 minute: <ul style="list-style-type: none"> Between all case terminals connected together and the case earth. Between all terminals of independent circuits with terminals on each independent circuit connected together.
Impulse Voltage Withstand Test	EN 60255-27:2005	<ul style="list-style-type: none"> Front time: 1.2 μs Time to half-value: 50 μs Peak value: 5 kV Source Characteristics: 500 Ohm, 0.5 J Common and differential mode: power supply, terminal block (excluding RS485), binary inputs, relays
Creepage Distances and Clearances	EN 60255-27:2005	<ul style="list-style-type: none"> Pollution degree 2 Overvoltage category III Impulse test voltage 5 kV

EMC Tests	Standard	Value
1 MHz Burst High Frequency Disturbance Test	EN 60255-22-1: 2008 Class III	<ul style="list-style-type: none"> Common-mode test voltage: 2.5 kV Differential test voltage: 1.0 kV Test duration: 2 s Source impedance: 200 Ω
Immunity to Electrostatic Discharge	EN 60255-22-2: 2008 Class 3	<ul style="list-style-type: none"> 8 kV discharge in air to all communication ports. 6 kV point contact discharge to any part of the front of the product
Electrical Fast Transient or Burst Requirements	EN 60255-22-4: 2008 Test severity Class III	<ul style="list-style-type: none"> Amplitude: 2 kV, Burst frequency 5 kHz (Class III)
Surge Immunity Test	EN60255-22-5: 2002; EN 61000-4-5: 2006, Level 3	<ul style="list-style-type: none"> Time to half-value: 1.2/50 μs, Amplitude: 2 kV between all groups and case earth, 1 kV between terminals of each group
Immunity to Radiated Electromagnetic Energy	EN 60255-22-3: 2008, Class III:	<ul style="list-style-type: none"> Test field strength, frequency band: 80 MHz to 1000 MHz: 10 V/m, 1.4 GHz to 2.7 GHz: 10 V/m Test using AM: 1 kHz / 80% sinus
Radiated Immunity from Digital Radio Telephones	EN 60255-22-3:2008	10 V/m, 900 MHz 100% AM, 200 Hz/50% square wave
Immunity to Conducted Disturbances Induced by Radio Frequency Fields	EN 61000-4-6: 2009, Level 3	Disturbing test voltage: 10 V, 150 Hz to 80 MHz, 80% AM, 1 kHz
Power Frequency Magnetic Field Immunity	EN 61000-4-8: 2010, Level 4	<ul style="list-style-type: none"> 30 A/m applied continuously, 300 A/m applied for 3 s
Conducted Emissions	EN 55022: 2010	<ul style="list-style-type: none"> 0.15 - 0.5 MHz, 79 dBμV (quasi peak) 66 dBμV (average); 0.5 - 30 MHz, 73 dBμV (quasi peak) 60 dBμV (average)
Radiated Emissions	EN 55022: 2010	<ul style="list-style-type: none"> 30 - 230 MHz, 40 dBμV/m at 10 m measurement distance; 230 - 1 GHz, 47 dBμV/m at 10 m measurement distance

(cont.)

EMC Tests	Standard	Value
Ambient Temperature Range	EN 60255-1: 2010	<ul style="list-style-type: none"> ■ Operating temperature range: -20°C to +60°C (-4°F to +140°F), ■ Temporarily permissible temperature: -40°C to +85°C (-40°F to +185°F) with double errors ■ Storage and transit: -25°C to +70°C (-13°F to +158°F)
Ambient Humidity Range	EN 60068-2-78: 2001 EN 60068-2-30: 2005	56 days at 93% relative humidity and +40°C. Damp heat cyclic, six (12 + 12) hour cycles, 93% RH, +25 to +55°C
Vibration Test	EN 60255-21-1: 1995	<ul style="list-style-type: none"> ■ Response Class 1 ■ Endurance Class 1
Shock and Bump	EN 60255-21-2: 1995	<ul style="list-style-type: none"> ■ Shock response Class 1 ■ Shock withstand Class 1 ■ Bump Class 1
Seismic	EN 60255-21-3:1995	Class 2
Enclosure Protection	EN 60529: 1991	<ul style="list-style-type: none"> ■ IP 40 Protection for relay housing ■ IP 20 Protection for terminals. ■ IP 54 Protection (front panel) against dust and dripping water for flash mounted case.

EMC Directives	Standard
EMC Compliance  2004/106/EC	Compliance with the European Commission's EMC Directive Product Specific Standards were used to establish conformity: <ul style="list-style-type: none"> ■ EN 60255-26: 2009 ■ EN 60255-1: 2010
Product Safety  2006/95/EC	Compliance with the European Commission's Low Voltage Directive. Compliance is demonstrated by reference to generic safety standards : <ul style="list-style-type: none"> ■ EN60255-27:2005



MiCOM P111

Numerical three phase and earth fault overcurrent relay description

PC151012b



2

The MiCOM P111 relays are suitable for all the applications where overcurrent and/or earth-fault protection are required.

P111 can be applied to medium and low voltage electrical systems as an optimized and cost efficient solution tailored to user's needs.

Customer benefits



- Flexible current relay
- Full set of measurement
- Good feature/price ratio
- Settings made easy
- Effortless installation

MiCOM P111 relays provide features for easy adaptation to different applications and operation conditions.

The P111 can be fully configured manually, without using setting software.

Alternatively, MiCOM S1 Studio setting software allows configuration parameters to be modified for a specific application via the USB port.

IEC 60870-5-103 and Modbus RTU integrated communication protocols are available for flexible integration into most substation control or DCS systems.

Close and Trip commands can be executed via functional key on the front panel, default menu window, DCS/SCADA system (RS485) or configured binary input.

Three level password gives proper rights for secure maintenance of the relay.

As a device housed in a small sized flush-mountable case, the P111 can be easily installed in all modern, dimension-focused switchgear panels.

The relay can be also considered as a cost-effective answer to retrofit demands of older substations.

Selectable measuring criteria: True RMS and/or fundamental frequency (Fourier) current measurements allow to increase selectivity and adapt to the application.

Application

The MiCOM P111 numerical overcurrent protection relays provide an optimized and cost efficient solution.

Typical applications are:

- Utility and industrial substation fitted with cost-optimized MV switchboards
- Retrofit relays of old technology, particularly during installation of DCS systems
- Transformers, incomers, bus couplers, capacitor banks, overhead lines and underground cables on MV systems
- Neutral system protection (insulated, solid and resistance earthed)
- LV substations

Main features

The following functions are generally available in all devices:

- Operate in 1, 2, or 3-phase arrangement.
- Two setting groups, selected from the relay menu, binary input or SCADA/DCS.
- Flush mounted case.
- Fundamental (fn) and True RMS (within a frequency range from 10Hz to 1kHz) phase current value measurement.
- Earth current fundamental (fn) frequency measurement.
- 9 button keypad to input settings, configure the relay and close and trip command and display (2x16 LCD).
- Fault record for most recent trips.

The P111 protection relays are comprised of full suite of protection functions as well as auxiliaries. Each function can be individually configured or disabled to suit every kind of application.

All available functions, including protection, automation, communication, LEDs, inputs and outputs, are easily programmable through the user-friendly human machine interface and/or the MiCOM S1 STUDIO software interface.

The 32 alphanumeric LCD provides the user with key information (faults, measurements, settings, etc). The menus have a pull-down structure for easy use and quick access to any data. User can switch HMI language directly through the front panel.

8 LEDs indicate the correct operation of the relay as well as other information regarding the protection of the electrical system.

The hardware architecture and software algorithms have been designed to operate on very short failure detection times. Tripping occurs typically within no more than 40 ms.

Power supply



Power Supply Nominal Burden Auxiliary Power Supply Vx	
Nominal auxiliary voltage Vx (ordering options)	<ul style="list-style-type: none"> ■ 24 – 60 Vdc/ 24 – 60 Vac (50/60Hz) (Models B, A, and E) ■ 90 – 250 Vdc/ 90 – 240 Vac (50/60 Hz) (Model B, A and E) ■ 24 – 250 Vdc/ 24 – 240 Vac (50/60 Hz) (Models L and N)
Operating range	<ul style="list-style-type: none"> ■ 19 – 72 V (dc), 19 – 66 V (ac) (Models B, A, and E) ■ 71 – 300 V (dc), 71 – 265 V (ac) (Model B, A and E) ■ 19 – 300 Vdc/ 19 – 265 Vac (50/60 Hz) (Models L and N)
Tolerable AC ripple	Up to 12% for a dc supply, per IEC 60255-11: 2008

Nominal Burden Auxiliary Power Supply Vx			
For AC max. approx.			
	Vx - V	S - VA	
		Initial position *	Active position **
24 – 60 Vac	24	2.5	4.5
	48	3.0	5.5
	110	4.0	6.5
90 – 240 Vac (L, N : 24 -240Vac)	220 / 230	6.0	9.0
	264	7.0	10.0
For DC Vx voltage max. approx.			
		S - W	
		Initial position *	Active position **
24 – 60 Vdc		1.5	3.5
90 – 240 Vdc		2.0	3.5
		(*) Initial position: no output nor LED energized	
		(**) Active position: all outputs and LEDs energized	

Auxiliary Power Supply Voltage Interruption	
IEC 60255-11: 2008	<p>Within the auxiliary supply range:</p> <ul style="list-style-type: none"> ■ 90-250Vdc, the relay will withstand a 50 ms; ■ 24-48Vdc, the relay will withstand a 20 ms <p>Interruption of the DC auxiliary supply without de-energizing.</p>
EN 61000-4-11: 1997	<p>Within the auxiliary supply range:</p> <ul style="list-style-type: none"> ■ 90-250Vac, the relay will withstand a 50 ms; ■ 24-48Vac, the relay will withstand a 20 ms <p>Interruption of the AC auxiliary supply without de-energizing.</p>

Power-up Time for Auxiliary Supply Voltage only
Time to power up via auxiliary supply: < 0.5s

Frequency and Current inputs

Frequency (Current inputs)

Nominal frequency	50 or 60 Hz (selectable in P111 menu)
-------------------	---------------------------------------

Phase current inputs

Nominal current (In)	1 or 5 A (selectable via HMI)
RMS measurement in range	40 Hz – 1 kHz
Fundamental harmonic measurement in range	40 Hz – 70 Hz
Operating range	0.1 – 40 In
Nominal Burden at In	<ul style="list-style-type: none"> ■ < 0.3 VA at In=5A ■ < 0.1 VA at In=1A
Thermal withstand	<ul style="list-style-type: none"> ■ 1 s @ 100 x rated current ■ 2 s @ 40 x rated current ■ 10 s @ 30 x rated current ■ continuous: 4 x rated current

Earth current inputs

Nominal current (Ien):	1 or 5 A (selectable via HMI)
Fundamental harmonic measurement in range	40 Hz – 70 Hz
Operating range	Selected at order (Cortec) <ul style="list-style-type: none"> ■ 0.01 – 2Ien ■ 0.05 – 12Ien ■ 0.01-12Ien (hardware option available in Model E)
Nominal Burden at Ien	< 0.3 VA at In=5A; < 0.1 VA at In=1A
Thermal withstand	<ul style="list-style-type: none"> ■ 1 s @ 100 x rated current ■ 2 s @ 40 x rated current ■ 10 s @ 30 x rated current ■ continuous @ 4 x rated current

Ien: earth fault input nominal current (Ien)

Binary inputs (optically isolated inputs)

Ordering Code of Vx	Filtering time approx.	Nominal Voltage range	Voltage operating range	Minimum polarisation voltage (Logic 1) approx.	Maximum polarisation current approx.	Maximum continuous withstand
1	20 ms	24 – 60 Vac/dc	19.2 – 66 Vac / dc	<ul style="list-style-type: none"> ■ 16 Vdc ■ 18 Vac 	12 mA (66V)	<ul style="list-style-type: none"> ■ 110 Vdc ■ 78 Vac
2	20ms	90 – 240 Vac/dc	71 – 264 Vac / dc	66 Vac/dc	2.5 mA (264V)	<ul style="list-style-type: none"> ■ 300 Vdc ■ 264 Vac

Binary input energy consumption

Logic input burden for Vx ordering code 0	R input = approx. 6 kOhm
Logic input burden for Vx ordering code 1	R input = approx. 109 kOhm
Logic input recognition time	As filtering time + 2 ms

Output Relay Characteristics

Contact ratings

Contact relay	Dry contact, Ag Ni
Carry capability	5 A continuous
Rated Voltage	250 Vac

Breaking characteristics for RL1, RL3 and WD

Short-duration capacity	25 A for 3 s
Making capacity	150 A for 30 ms
AC breaking capacity	<ul style="list-style-type: none"> ■ 1250 VA resistive ($\cos \phi = \text{unity}$) ■ 1250 VA inductive ($\cos \phi = 0.7$)
DC breaking capacity	<ul style="list-style-type: none"> ■ 250 Vdc ■ 50 W resistive ■ 25 W inductive ($L/R = 40 \text{ ms}$)
Operation time	<10 ms

Durability

Loaded contact	10 000 operations minimum
Unloaded contact	100 000 operations minimum

Breaking characteristics for RL4 RL5, RL6, RL7, RL8

Short-duration capacity	25 A for 3 s
Making capacity	150 A for 30 ms
AC breaking capacity	<ul style="list-style-type: none"> ■ 1250 VA resistive ($\cos \phi = \text{unity}$) ■ 1250 VA inductive ($\cos \phi = 0.7$)
DC breaking capacity	<ul style="list-style-type: none"> ■ 250 Vdc ■ 50 W resistive ■ 25 W inductive ($L/R = 40 \text{ ms}$)
Operation time	< 10 ms

Durability

Loaded contact	10 000 operations minimum
Unloaded contact	100 000 operations minimum

Functional overview

(Description of ANSI code nos., see Protection Functions Table)

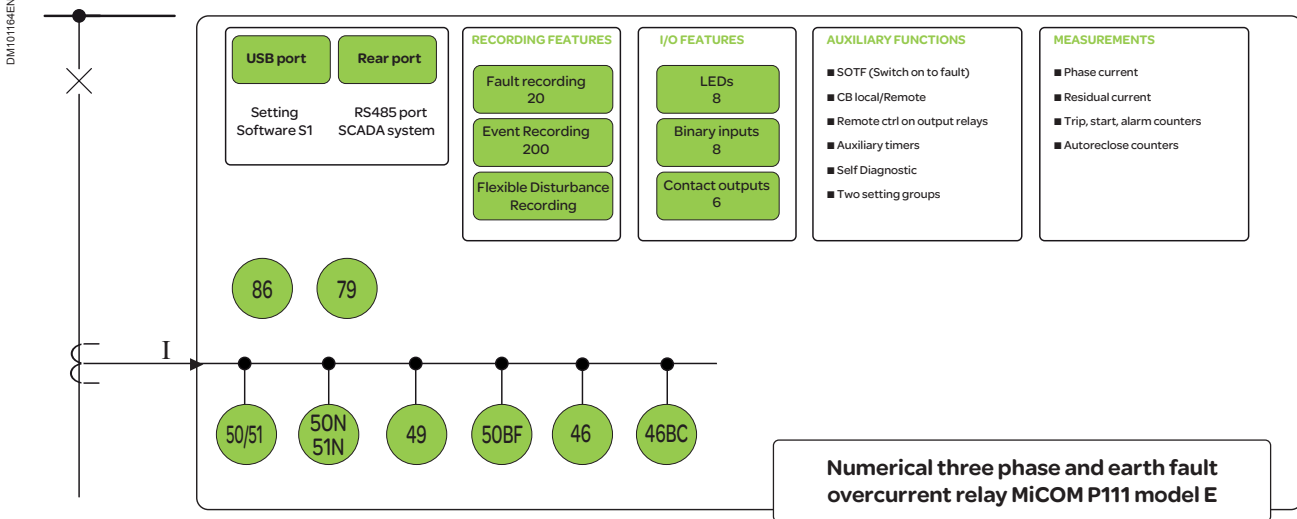

ANSI Code	Functions	Models				
		L	N	B	A	E
49	Thermal overload (true RMS): 2 independent thresholds (Alarm, Trip)		■	■	■	■
50BF	Circuit breaker failure	■	■	■	■	■
50/51	Three-phase non directional overcurrent: 3 independent thresholds (12 groups of IDMT curves)	■	■	■	■	■
	Switch on to fault (SOTF)			■	■	■
	Inrush blocking				■	■
	Blocking logic			■	■	■
	Selective relay scheme logic					■
	Cold Load Pick-Up	■	■	■	■	■
50N/51N	Phase-earth non directional overcurrent: 2 independent thresholds (12 groups of IDMT curves)	■	■	■	■	■
46	Negative phase sequence overcurrent					■
46BC	Broken conductor detection (I2/I1)					■
79	Autorecloser (4 shots)					■
86	Output relay latching	■	■	■	■	■
	2 setting groups	■	■	■	■	■
	Self-monitoring feature with watchdog contact WD	1	1	1	1	1
	Freely configurable binary inputs / output relays (watchdog contact WD included)	0/4	0/6	4/4	4/8	8/6
	8 signalling LEDs ("Healthy" + "Trip" + "Alarm" + 5 freely configurable LEDs)	■	■	■	■	■
	Circuit breaker supervision and counters				■	■
	Trip circuit supervision				■	■
	Fault records for the 20 most recent trips	■	■	■	■	■
	Event records (up to 200 events)		■	■	■	■
	Disturbance records (up to 5 s)				■	■
	LCD display	■	■	back-lit	back-lit	back-lit
	Front USB port for local downloading of settings, events and/or fault records		■	■	■	■
	Rear port RS485 communications (Modbus RTU and IEC60870-5-103)	Option	■	■	■	■
	Measurements	■	■	■	■	■
	CB control: HMI, via binary input or RS485			■	■	■
Setting software: MiCOM S1 and/or S1 Studio		■	■	■	■	
Optional cassette (adaptor) for wall-mounted solution	■	■	■	■	■	
Optional front cover preventing from unauthorized access	■	■	■	■	■	

(cont.)

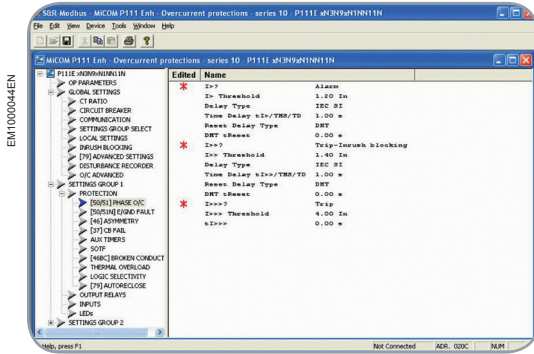

Thermal Overload (49)

The protection of transformers and cables must take into account their particular thermal characteristics.

MiCOM P111 relays include a thermal replica element based on the true RMS value of the current, up to the 10th harmonic. Alarm and Trip overload thresholds and time constant are fully programmable to match each application requirement.

Circuit Breaker Failure (50BF)

The circuit breaker failure protection function verifies the effective opening of the CB using a dedicated undercurrent threshold.

The circuit breaker failure function can be activated by the trip of an internal protection function and/or an external command through the relevant digital input. The circuit breaker failure protection function can also be used to trip upstream circuit breakers.

Three-Phase Overcurrent (50/51) & Earth Fault Overcurrent (50N/51N)

Three independent stages are available both for phase and earth fault protection. For the first and second (50/51 only) stages the user may independently select a definite time delay (DMT) or an inverse time delay (IDMT) with different types of curves (IEC, IEEE, RI, RECT, RXIDG, BNP EDF).

Each stage and related time-delay can be programmed to provide maximum selectivity.

The IDMT stages have a selectable reset feature: DMT (0 to 600 s) or an IDMT timer so as to reduce clearance times when intermittent faults occur.

The MiCOM P111 relays have separate instantaneous and delayed indications for each stage and output relays and LEDs can be configured to indicate the faulted phase(s).

Each protection stage can be disabled, configured to trip a circuit-breaker or to issue an ALARM signal only.

Switch-on-to-Fault (based on 50/51)

The closing of a circuit breaker might inadvertently lead to a short-circuit fault due to a maintenance ground clamp not yet removed. The P111 relays incorporate a settable switch-on-to-fault protection function. It provides an instantaneous trip over a settable time period after local or remote manual closure.

Inrush current in transformer applications can have an influence on the selectivity of instantaneous trips; the short time-delay (DMT) can therefore be set for this protection element in order to maintain selectivity and make it possible to have a current threshold below any inrush current peak.

One independent DMT current stage is available for phase fault protection.

Inrush Blocking

The 2nd Harmonic Blocking detects high inrush current inflows that occur upon connection of transformers or rotating machines. The function will block the phase overcurrent and earth fault elements (freely selectable).

Blocking Logic

When MiCOM P111 relays are used in critical networks, the management of protection relays must take surrounding devices into consideration. Any blocking digital inputs can be independently configured to lock any combination of selected elements (i.e. current stages, thermal replica, etc).

A typical application is to use a dedicated digital input to block the time-delayed settings of phase/earth fault protection in a relay in response to the phase/earth fault start condition of a downstream relay.

This function allows the MiCOM relays to clear the fault quickly and correctly when used in a cascading scheme.

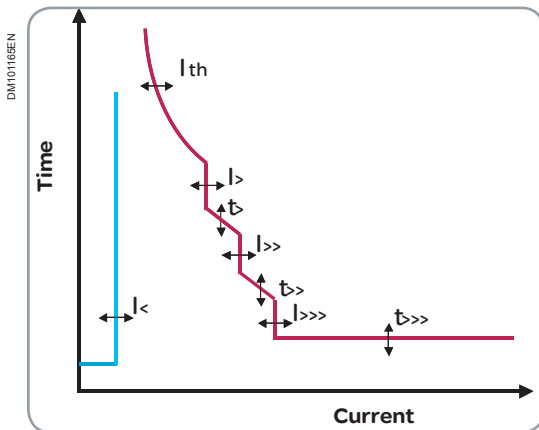

(cont.)

2

Selective Relay Scheme Logic

The MiCOM P111 relays (Model E) include selective relay scheme logic. A dedicated digital input can temporarily alter the time delay settings in response to the phase/earth fault start condition of a downstream relay. This function allows the MiCOM relays to quickly clear the fault when used in a cascade scheme.

Cold Load Pick-Up

Cold load pick-up temporarily raises the setting of selectable stages closer to the lad profile in order to avoid unwanted trips.

The setting value can be increased by 800% for example for a settable duration. To trigger this function, the CB closed position or current criteria are used.

Negative Sequence Overcurrent (46)

The MiCOM P111 relays (model E) include a programmable function specially designed to detect unbalanced load or fault conditions.

The three stages of negative sequence overcurrent have the same setting ranges and time delay as the phase overcurrent.

Broken Conductor (46BC)

A typical unbalanced fault that can occur on the system is an open circuit fault. This fault can arise from broken conductor, discrepancy of one switchgear poles position or blowing of a fuse.

MiCOM P111 relays (Model E) are able to measure the ratio of negative to positive sequence current ($I2/I1$). This fully programmable function allows more sensitivity and stability than pure negative sequence measurement

Autorecloser (79)

MiCOM P111 relays (Model E) include a 4-shot triphase autorecloser. All the programmed protection functions may independently start any of the shots and the user can program which functions are allowed to trip after any of the shots. This makes possible special reclosing cycles e.g. as requested for coordination with fuses in distribution with tapped transformers.

To prevent excessive number of reclosing cycle in a short period of time, a setting can be used to define the maximum number of reclosing cycle allowed in a period of time after first one was detected. Dead and reclaim times are freely adjustable. A counter stores the number of reclose commands. This information is free locally or remotely. To inform operator that autorecloser has been blocked internally or externally, output relays can be assigned to these signals.

Output Relay Latching (86)

All output contacts may be latched freely.

Latched outputs can be reset via the activation of a logic input through the front panel interface or by remote communication.

Instantaneous Information

Outputs and LEDs can be programmed with instantaneous information from freely selectable protection elements: with or without latching.

Additionally, every start of a protection element is recorded in the event recorder and the instantaneous recorder.

The instantaneous information is typically generated within 30 ms after the threshold has been exceeded.

Trip Via Binary Input

Opto-isolated binary inputs are freely configured to timers AUX1-AUX4. This function works if inputs are triggered via the auxiliary voltage.

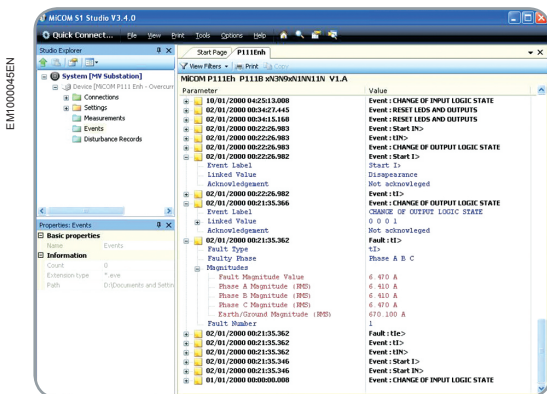

Communication & Synchronization

The MiCOM P111 offers a wide range of communication protocols allowing its utilization in most network control and data acquisition systems (via Modbus, IEC 60870-5-103). The protocol can be selected in the P111 mlt has been designed for permanent multi-drop connection through the rear RS485 communication port.

The MiCOM P111 incorporates an internal clock to allow 1 ms accuracy time tagging of alarms, events, fault and disturbance records. To avoid any drifting of the time-tagging clock, it's necessary to periodically synchronize the relays. To do this the P111 offers a solution:

- Synchronization from the substation control sysThe back-up capacitor of the internal clock is charged from an auxiliary voltage supply and supports the internal clock typically up to t

Two Setting Groups

External conditions may require the need for different settings or I/O configuration. The MiCOM P111 provides two independent setting groups. The active setting group can be switched from the local HMI or due to external conditions (digital input change of state or DCS control).

The two setting groups include protection settings, binary input, output and LED configuration.

Local/Remote Mode of CB Commands

The goal of this feature is to make it possible to block commands sent remotely through communication networks (such as setting parameters, control commands, etc.) in order to prevent any accidents or maloperation during maintenance work performed on site.

The local mode can be set via a digital input assigned to this feature or an RS485. The local mode state can be indicated via the configured LED.

Circuit Breaker/Contactor Command

Circuit breaker control is available from the front panel user interface, optically-isolated inputs and remotely via substation communications. Circuit breaker control is also possible via the function keys (Close/Open).

For contactor application the output contact has to be configured with reverse logic&latching.

It is possible to send a local open/close command through the HMI upon operator confirmation.

Circuit Breaker Condition Monitoring

The circuit breaker condition monitoring features include:

- Monitoring the number of breaker trip operations
- Recording the sum of the broken current quantity ΣI^x , (where x: 1 or 2)
- Monitoring the breaker operating time

An alarm signal is emitted if the above parameters exceed the settable threshold.

Timers AUX1, AUX2, AUX3, AUX4

Timers operate if the state of an input mapped to this function changes in such a way that the function will be triggered. Timers can be used for CB tripping or alarm signalling.

This function is available when inputs are energised via an auxiliary power supply.

To upload them, it is possible to use the front USB port (MiCOM S1 Studio) or the rear serial port (DCS). Event records are stored in a non volatile FRAM memory. All events are time-stamped to 1 ms.

Fault & Alarm Recording

The last 20 faults and 5 alarms records are stored inside the MiCOM P111 relays.

Each fault includes: Record number/ Fault time / Active setting group / Faulted phase / Protection operation / Magnitude of input quantities.

Fault indication helps the user to clearly identify the fault and monitor the relay's settings and operations as all information is available on the relay HMI.

Fault records are stored in a non-volatile FRAM memory.

(cont.)

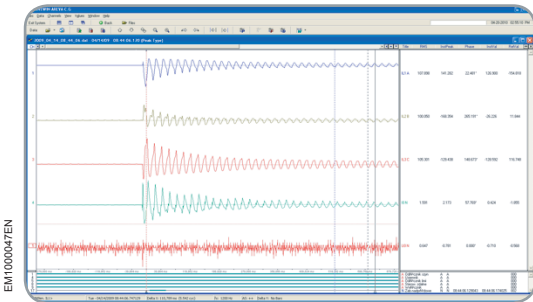

WaveWin – Data Analyzer Software

Event Recording

200 events are stored in the MiCOM P111 relays. Events include input/output state changes, alarms and contact operations.

Disturbance Recording

Up to 5 disturbance files are stored in the relay. Even if the total duration is set to 4 s, it is fully adjustable for easy adaptation to customer requirements. They are stored in COMTRADE format.

The disturbance recording function is triggered either by any of the programmed thresholds, by an external input, or through the communications. All digital and analog information is stored in non-volatile FRAM memory and can be transferred using the front communication port or the rear port to be used by an external data analyser. Disturbance records are stored in a non-volatile FRAM memory.

Trip Supervision

Trip circuit supervision in both circuit breaker open and closed states is possible using the optically isolated-inputs included in the P111 scheme logic.

I/O Configuration

Every input and output can be freely configured to available functions (blocking of protection element, reset LED or outputs, start, trip of every protection element, etc). Any input and output can be assigned to any predefined function.

Relay Maintenance Mode

The P111 incorporates direct control of the output relays (without the need to inject any current). This functionality allows the user to quickly check the external wiring of the relay's output contacts.

Support Software

MiCOM S1 Studio and MiCOM S1 (Windows™ compatible) support software is available for the entire MiCOM family, including the P111 relays.

This Support Software is used to set all parameters in the P111 or download setting parameters, fault and event records. Communication with a PC is managed by the front USB port of the P111.

Self-Monitoring

Comprehensive self-monitoring procedures within the P111 ensure that internal hardware or software errors are detected and do not cause malfunctions of the device. When the auxiliary voltage is turned on, a functional test is carried out. Cyclic self-monitoring tests are run during operation. Any deviations are stored in non-volatile memory and determines whether protection is blocked or an alarm is raised. The result of the fault diagnostics determines whether the protection unit will be blocked or only an alarm will emitted.

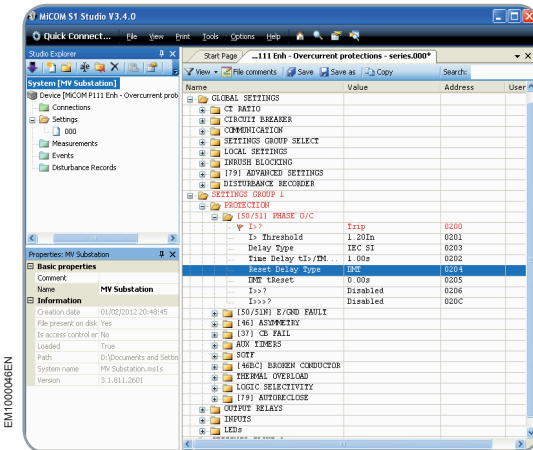

Protection functions setting ranges

Functions	Setting range		
	min.	max.	Steps
[49] Thermal overload (Models N, B, A and E)			
Therm. OL ?	Disabled, Enabled		
ltherm	0.1 In	3.0 In	0.01In
Te (heating)	1 mn	200 mn	1mn
Tr (cooling)	1 mn	999 mn	1mn
Theta Trip	50%	200%	1%
Theta Reset Ratio	20%	99%	1%
Theta Alarm ?	Disabled, Enabled		
Theta Alarm	20%	200%	1%
[50/51] Phase overcurrent			
I> ?	Disabled, Trip, Alarm, Trip with Inrush blocking (A, E), Trip Latch (A, E)		
I>	0.1 In	4 In (IDMT) 40 In (DMT)	0.01 In
Delay type	DT or IDMT (IEC_SI, IEC_VI, IEC_EI, IEC_LTI, IEC_STI, C02_P20, C08, IEEE_MI, IEEE_VI, IEEE_EI, RXIDG, BPN EDF, RI, RECT, C02_P40 curve)		
tI>	0.05 s	200 s	0.01 s
I> TMS	0.02	1.50	0.01
I> TD	0.02	100	0.01
I> Reset Delay Type	DT or IDMT		
DT I> tReset	0.00 s	600 s	0.01 s
K (RI)	0.1	10	0.1
I>> ?	Disabled, Trip, Alarm, Trip with Inrush blocking (A, E), Trip Latch (A, E)		
I>>	0.1 In	4 In (IDMT) 40 In (DMT)	0.01 In
Delay type	DT or IDMT (IEC_SI, IEC_VI, IEC_EI, IEC_LTI, IEC_STI, C02_P20, C08, IEEE_MI, IEEE_VI, IEEE_EI, RXIDG, BPN EDF, RI, RECT, C02_P40 curve)		
tI>>	0.05 s	200 s	0.01 s
I>> TMS	0.02	1.50	0.01
I>> TD	0.02	100	0.01
I>> Reset Delay Type	DT or IDMT		
DT I>> tReset	0.00 s	600 s	0.01 s
K (RI)	0.1	10	0.01
I>>> ?	Disabled, Trip, Alarm, Trip with Inrush blocking (A, E), Trip Latch (A, E)		
I>>>	1 In	40 In	0.01 In
tI>>>	0 s	200 s	0.01 s
[50/51] SOTF (switch on to fault) (Model B, A and E)			
SOTF ?	Disabled, Trip, Alarm, Trip with Inrush blocking, Trip Latch		
SOTF	1 In	40 In	0.01 In
tSOTF	0 s	600 s	0.01 s
[50/51N] Phase-earth non directional overcurrent			
High sensitivity current set			
Cortec code P111xxx0xxxxxxxxxxx (0.01-2Ien)			
IN_1 (IN>)	0.01 Ien	0.2 Ien (IDMT) 2.0 Ien (DMT)	0.01 Ien
IN_2 (IN>>)	0.05 Ien	2.0 Ien	0.01 Ien
IN_3 (IN>>>) (Model E)	0.05 Ien	2.0 Ien	0.01 Ien
Low sensitivity current set			
Cortec code P111xxx3xxxxxxxxxxx (0.05-12Ien)			
IN_1 (IN>1)	0.05 Ien	1.2 Ien (IDMT) 12 Ien (DMT)	0.01 Ien
IN_2 (IN>>)	0.3 Ien	12 Ien	0.01 Ien
IN_3 (IN>>>) (Model E)	0.3 Ien	12 Ien	0.01 Ien
Extended current set (Model E only)			
Cortec code P111xxx4xxxxxxxxxxx (0.01-12Ien)			
IN_1 (IN>1)	0.01 Ien	1.2 Ien (IDMT) 12 Ien (DMT)	0.01 Ien
IN_2 (IN>>)	0.3 Ien	12 Ien	0.01 Ien
IN_3 (IN>>>)	0.3 Ien	12 Ien	0.01 Ien

(cont.)

Functions	Setting range		
	min.	max.	Steps
[50/51N] Phase-earth non directional overcurrent (cont.)			
IN_1 (IN>) stage?	Disabled, Trip, Alarm, Trip with Inrush blocking (A, E), Trip Latch (A, E)		
Delay type	DT or IDMT (IEC_SI, IEC_VI, IEC_EI, IEC_LTI, IEC_STI, C02_P20, C08, IEEE_MI, IEEE_VI, IEEE_EI, RXIDG, BPN EDF, RI, RECT, C02_P40 curve)		
tIN_1 (tIN>)	0.05 s	200 s	0.01 s
IN_1 (IN>) TMS	0.02	1.50	0.01
IN_1 (IN>) TD	0.02	100	0.01
IN_1 (IN>) Reset Delay Type	DT or IDMT		
DT IN_1 (IN>) tReset	0.00 s	600 s	0.01 s
K (RI)	0.1	10	0.1
IN_2 (IN>>) stage?	Disabled, Trip, Alarm, Trip with Inrush blocking (A, E), Trip Latch (A, E)		
tIN_2 (tIN>>)	0 s	200 s	0.01 s
IN_3 (IN>>) stage? (Model E)	Disabled, Trip, Alarm, Trip with Inrush blocking (A, E), Trip Latch (A, E)		
tIN_3 (tIN>>) (Model E)	0 s	200 s	0.01 s
Blocking Inrush (Model A and E)			
Blocking inrush	No, Yes, Closing		
2nd Harmonic Ratio	10%	50%	1%
Inrush Reset Time	0 s	200 s	10 ms
Unblock Inrush Time	0 s	200 s	10 ms
Auxiliary timers (Model B, A and E)			
Aux1 ?	Disabled, Trip, Alarm, Trip with Inrush blocking (A,E), Load Shedding LS (E), AR after LS via Hi Input state (E), AR after LS via Lo Input state (E)		
Time-delay tAux1	0	600 s	10 ms
Aux2 ?	Disabled, Trip, Alarm, Trip with Inrush blocking (A,E), Load Shedding LS (E), AR after LS via Hi state of Input (E), AR after LS via Lo state of Input (E)		
Time-delay tAux2	0	600 s	10 ms
Aux3 ?	Disabled, Trip, Alarm, Trip with Inrush blocking (A,E), Load Shedding LS (E), AR after LS via Hi Input state (E), AR after LS via Lo Input state (E)		
Time-delay tAux3	0	600 s	10 ms
Aux4 ?	Disabled, Trip, Alarm, Trip with Inrush blocking (A,E), Load Shedding LS (E), AR after LS via Hi Input state (E), AR after LS via Lo Input state (E)		
Time-delay tAux4	0	600 s	10 ms
Cold Load PU			
Cold Load PU ?	Disabled or Current+Input or Input (A, E)		
Cold load PU Level	20%	999%	1%
Cold load PU tCL	0s	6000 s	100 ms
CLPU I>	Yes or No		
CLPU I>>	Yes or No		
CLPU I>>>	Yes or No		
CLPU IN_1 (IN>)	Yes or No		
CLPU IN_2 (IN>>)	Yes or No		
CLPU ltherm (NA)	Yes or No		
[46] Negative Sequence Overcurrent			
I2> ?	Disabled, Trip, Alarm, Trip with Inrush blocking (A, E), Trip Latch (A, E)		
I2>	0.1 In	4 In	0.01 In
Delay type	DT or IDMT (IEC_SI, IEC_VI, IEC_EI, IEC_LTI, IEC_STI, C02_P20, C08, IEEE_MI, IEEE_VI, IEEE_EI, RXIDG, BPN EDF, RI, RECT, C02_P40 curve)		
tI2>	0.05 s	200 s	0.01 s
I2> TMS	0.02	1.50	0.01
I2> TD	0.02	100	0.01
IN_2 (IN>) Reset Delay Type	DT or IDMT		
DT I2> tReset	0.00 s	600 s	0.01 s

(cont.)

Functions	Setting range		
	min.	max.	Steps
[46BC] Broken Conductor (Model A and E)			
I2> ?	Disabled, Trip, Alarm, Trip with Inrush blocking (A, E), Trip Latch (A, E)		
Ratio I2/I1	20%	100%	1%
tBCond>	0.05 s	200 s	0.01 s
Brkn. Cond I< Block	0.1 In	1 In	0.01 In
[50BF] Circuit breaker failure			
CB Fail ?	Disabled, Retrip, Alarm		
CB Fail Time tBF	0.1 s	10 s	0.01 s
I< CBF	0.1 In	2 In	0.01 In
High sensitivity current setting			
P111xxx0xxxxxxxxxxx (0.01-2len)			
IN< CBF	0.1 len	2 len	0.01 len
Low sensitivity current setting			
P111xxx3xxxxxxxxxxx (0.05-12len)			
IN< CBF	0.1 len	2 len	0.01 len
Extended current set (Model E only)			
Cortec code P111xxx4xxxxxxxxxxx (0.01-12len)			
IN<CBF	0.1 len	2 len	0.01 len
[79] Autoreclose (Model E)			
Autoreclose ?	Disabled or Enabled		
Dead time tD1	0.01s	600s	0.01s
Dead time tD2	0.01s	600s	0.01s
Dead time tD3	0.01s	600s	0.01s
Dead time tD4	0.01s	600s	0.01s
Reclaim Time tR	0.02s	600s	0.01s
Fast O/C Trip (I>, I>>, I>>>)	Enabled or Disabled for every cycle		
Fast O/C Trip Delay setting	0.00s	9.99s	0.01s
Fast E/GND Trip	Enabled or Disabled for every cycle		
Fast E/GND Trip Delay setting	0.00s	9.99s	0.01s
Close Shot tI>	Enabled or Disabled for every cycle		
Close Shot tI>>	Enabled or Disabled for every cycle		
Close Shot tI>>>	Enabled or Disabled for every cycle		
Close Shot tIN_1 (IN>)	Enabled or Disabled for every cycle		
Close Shot tIN_2 (IN>>)	Enabled or Disabled for every cycle		
Close Shot tIN_3 (IN>>>)	Enabled or Disabled for every cycle		
Close Shot tAUX1	Enabled or Disabled for every cycle		
Close Shot tAUX2	Enabled or Disabled for every cycle		
Inhibit Trip tI>	Enabled or Disabled for every cycle		
Inhibit Trip tI>>	Enabled or Disabled for every cycle		
Inhibit Trip tI>>>	Enabled or Disabled for every cycle		
Inhibit Trip tIN_1 (IN>)	Enabled or Disabled for every cycle		
Inhibit Trip tIN_2 (IN>>)	Enabled or Disabled for every cycle		
Inhibit Trip tIN_3 (IN>>>)	Enabled or Disabled for every cycle		
Inhibit Trip tAUX1	Enabled or Disabled for every cycle		
Inhibit Trip tAUX2	Enabled or Disabled for every cycle		
Ext. CB Faulty Monitoring ?	Yes or No		
Ext. Block via Input?	Yes or No		
Start Dead Time on	Protection Reset or CB trips		
Rolling Demand ?	Yes or No		
Max. cycle number Roll. Dem.	2	100	1
Time period Rolling Demand	1 mn	24 h	1 mn
Time Inhibit on Close tI	0.0 s	600 s	0.01 s
Signalling Reset	No or on Close [79]		

2

Protection functions setting ranges (cont.)

Functions	Setting range		
	Min.	Max.	Step
Logic Selectivity (Model E)			
SEL1 ?	Disabled or Enabled		
tSEL1	0.00 s	600.0 s	0.01s
SEL1 tI>>	Yes or No		
SEL1 tI>>>	Yes or No		
SEL1 tIN>>	Yes or No		
SEL1 tIN>>>	Yes or No		
SEL2 ?	Disabled or Enabled		
tSEL2	0.00 s	600.0 s	0.01s
SEL2 tI>>	Yes or No		
SEL2 tI>>>	Yes or No		
SEL2 tIN>>	Yes or No		
SEL2 tIN>>>	Yes or No		

Control & monitoring functions setting ranges

Functions	Models	Setting range		
		Min.	Max.	Step
CB Control time				
tOpen Pulse min	All models	0.1 s	10 s	0.01 s
tClose Pulse	All models	0.1 s	10 s	0.01 s
Time-delay for Close	Model A	0.0 s	200 s	0.01 s
Time-delay for faulty CB external signal (Model B, A and E)				
tCB FLT ext		1 s	200 s	1 s
Remote control mode (Model A and E)				
Remote CTRL Mode		<input type="checkbox"/> Remote only <input type="checkbox"/> Remote + Local		
[52] Unblock SOTF Time Pulse after CB Close (Model B, A and E)				
52 Unblock SOTF Time		0 s	200 s	0.01 s
Trip Circuit (TC) Supervision (Model A and E)				
TC Supervision ?		<input type="checkbox"/> No <input type="checkbox"/> Yes <input type="checkbox"/> Yes / 52A		
TC Supervision tSUP		0.1 s	10 s	0.01 s
Circuit breaker control and monitoring setting ranges (Model A and E)				
CB Time Supervision?	Yes or No			
CB Open time	0.01 s	10 s	0.01 s	
CB Close time	0.01 s	10 s	0.01 s	
CB Diagnostic ?	Yes or No			
Max CB Open NB	1	50000	1	
Σ Amps(n)	0.1 MA^n	6535.5 MA^n	0.1MA^n	

Recording functions setting ranges

Disturbance records (Model A)				
Functions	Value			
Triggers	Any protection stage selected to trip CB, logical input , remote command			
Data	<ul style="list-style-type: none"> ■ AC input channels ■ Digital input and output states ■ Frequency value 			
Functions	Default value	Setting range		
		Min.	Max.	Step
Pre-fault Time	0.1	0.1	2	0.01
Post-fault Time	0.1	0.1	1	0.01
Max duration time	3	0.10	4	0.01
Disturb rec Trig	on Inst	<ul style="list-style-type: none"> ■ on Trip ■ on Inst. 		
Trigger	<ul style="list-style-type: none"> ■ Start signal of protection selected for tripping ■ Trip signal of protection selected for tripping ■ Logic input (Start Distur.R.) 			
Event records (not available in model L without RS485)				
Capacity	200 events			
Time-tag	1 millisecond			
Triggers	<ul style="list-style-type: none"> ■ Any selected protection alarm and threshold ■ Logic input change of state ■ Setting changes ■ Self test events 			
Fault records				
Capacity	20 faults			
Time-tag	1 millisecond			
Triggers	Any selected protection which trip CB			
Data	<ul style="list-style-type: none"> ■ Fault date ■ Protection thresholds ■ Setting Group ■ AC inputs measurements ■ Fault measurements 			
Alarm recorder				
Capacity	5 alarm information			
Time-tag	1 millisecond			
Triggers	Any selected protection which is selected for signaling only (set to Alarm)			
Data	Date, hour, origin (any protection alarm)			



2

PCI51007a



Presentation

User-Machine Interface (HMI)

All functions, including protection, automation, communication, LEDs, inputs and outputs, can be programmed and modified using the front panel user interface (Human Machine Interface).

The LCD informs the user about settings, measurements & faults with a pull-down menu structure allowing easy and quick access to any data.

Working language

The relay display language can be changed in the menu system.

All the texts and messages displayed on HMI are available in:

- English/German/French/Spanish/Russian/Turkish /Regional.
(Polish or Czech can overwrite on "Regional")

Wiring

External connections are made via screw terminals.

The screw terminals allow connection of threaded wires of up to 2.5 mm² or solid wires of 4 mm² of conductor cross section, with the exception of current terminals that have up to 4mm² for threaded wires and 6mm² for solid wires.

Communication

Type port	Physical link	Connectors	Data rate	Comms. mode	Protocol
RS485	Screened twisted pair	Screws or snap-on	4.8 or 9.6 or 19.2 or 38.4 (default:19.2 kbit/s)	<ul style="list-style-type: none"> ■ Data Bit: 8 ■ Stop bit: 1/ 2 ■ Parity: None/Odd/Even ■ Address: 1 to 254 	<ul style="list-style-type: none"> ■ Modbus RTU, IEC60870-5-103 (selectable in menu)
USB	USB2.0	PC: type A male P111: type mini B male	115.2 kbits/s (fixed)	<ul style="list-style-type: none"> ■ Data Bit:8 ■ Stop bit: 1 ■ Parity: None ■ Address: 1 	<ul style="list-style-type: none"> ■ Modbus RTU

(cont.)

Case

All the models of P111 have a flush mounting plastic case:

Dimensions

- Height 106.5 mm
- Width 106.5 mm
- Depth 118 mm

Weight

- P111 approx.0.5 Kg

Wall mounting solution is possible by using the wall mounting adapter (accessories).

Dimensions & weight

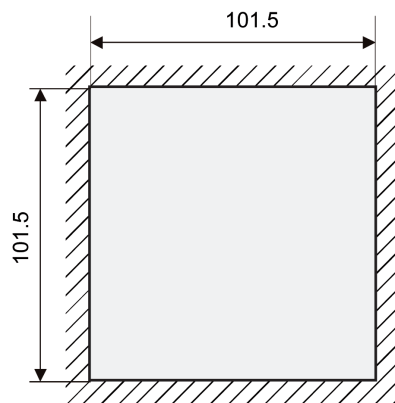
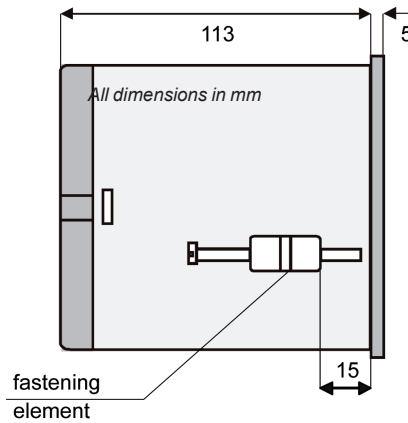
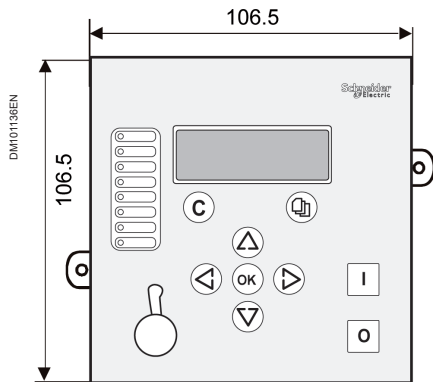

Cut-out



(cont.)

2

Front panel description

- 1 Green "Healthy" LED : Watchdog
- 2 Red "Trip" LED : Protection trip
- 3 Yellow "Alarm" LED : Alarm signalling
- 4
- 5
- 6 Red programmable LED
- 7
- 8
- 9 Alphanumeric liquid crystal display:
16 character by 2 line
- 10 CLEAR key
- 11 READ key
- 12 An ENTER key, 4 ARROW keys
- 14 CB CLOSE key
- 15 CB OPEN key
- 16 USB port for local connection

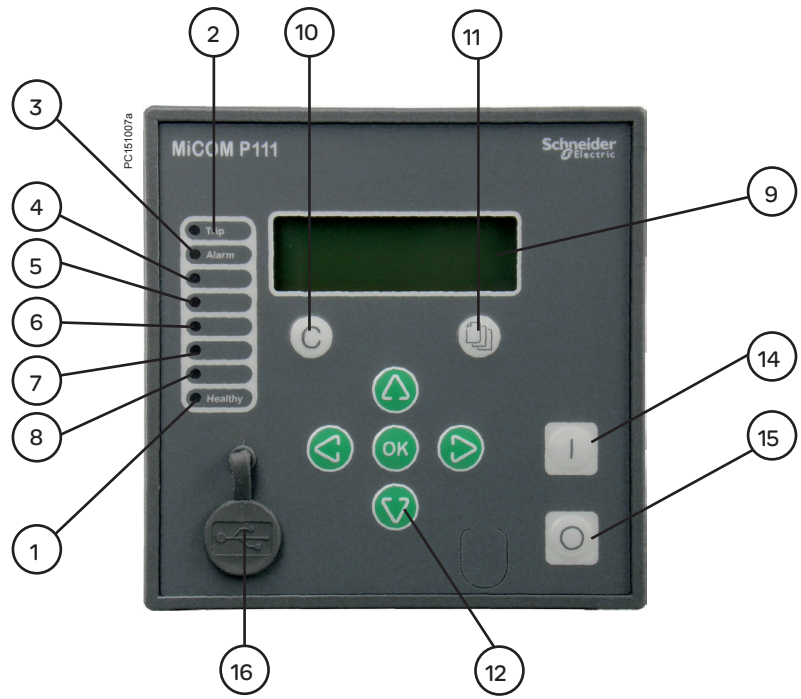

Rear panel description

- 1 Terminal block A:
 - Auxiliary voltage Vaux
 - Contact outputs: WD, RL1-RL3
 - Binary inputs: L1, L2
 - RS485
- 2 Current ring terminal block B:
 - Contact outputs
RL6, RL7 (**model A**) or RL4, RL5 (**model E**)
 - Binary inputs:
L3, L4 (**model A**) or L5, L6, L7, L8 (**model E**)
- 3 Terminal block B:
 - Current analogue inputs (phases and earth)
 - Output contacts RL4, RL5 (**models N / A**)
 - Binary inputs:
L3, L4 (**model E**)

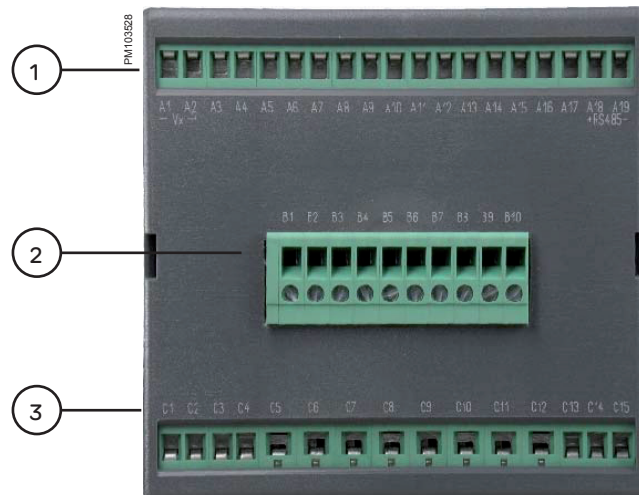

Model L external connection diagrams

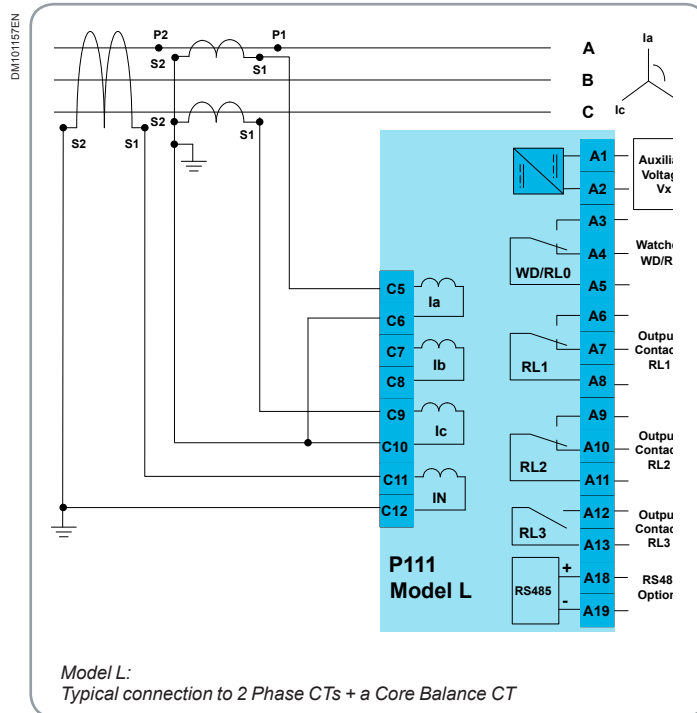
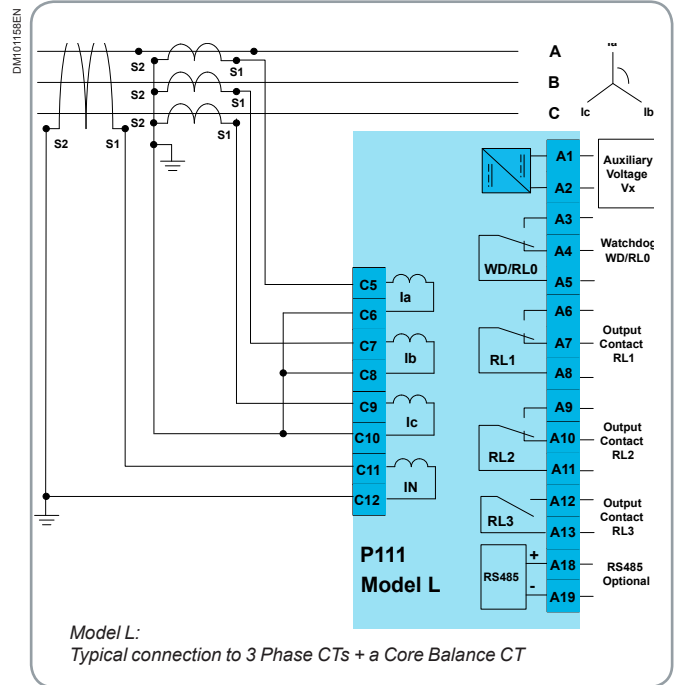
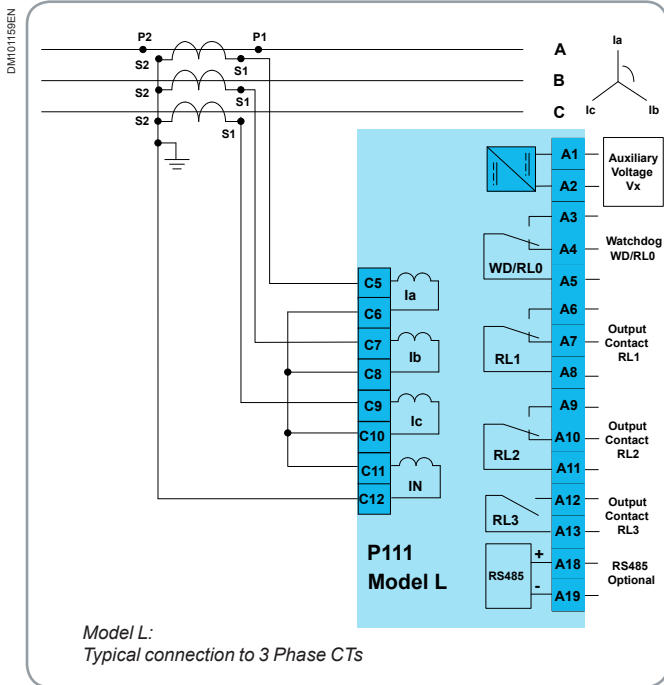

MiCOM P111

Base Unit

(cont.)

Model N external connection diagrams

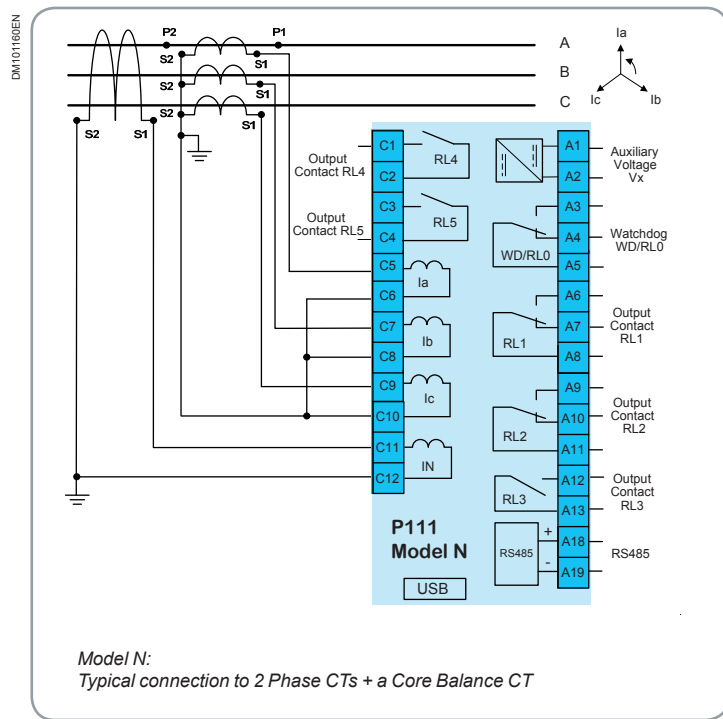
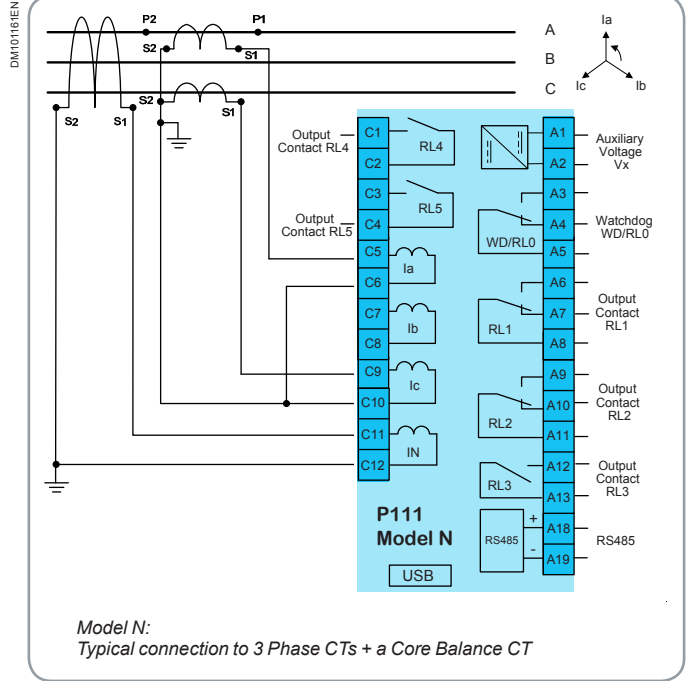
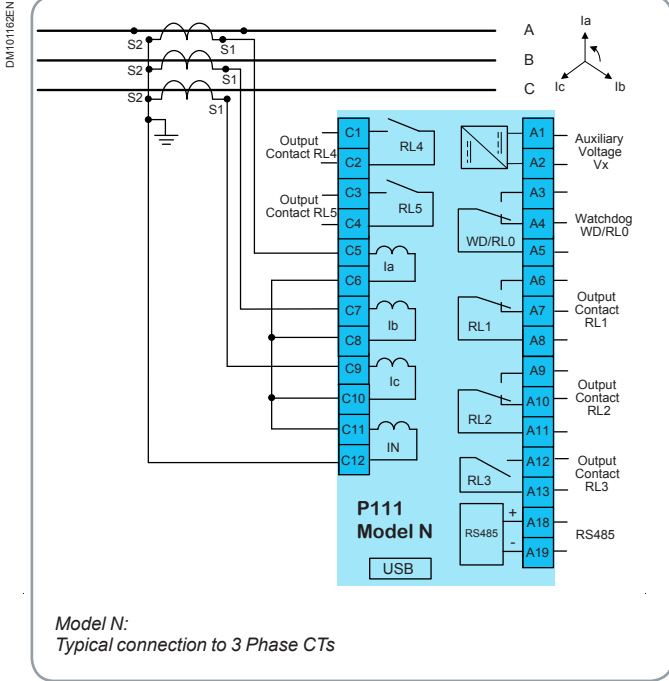

2

(cont.)

Model B external connection diagrams

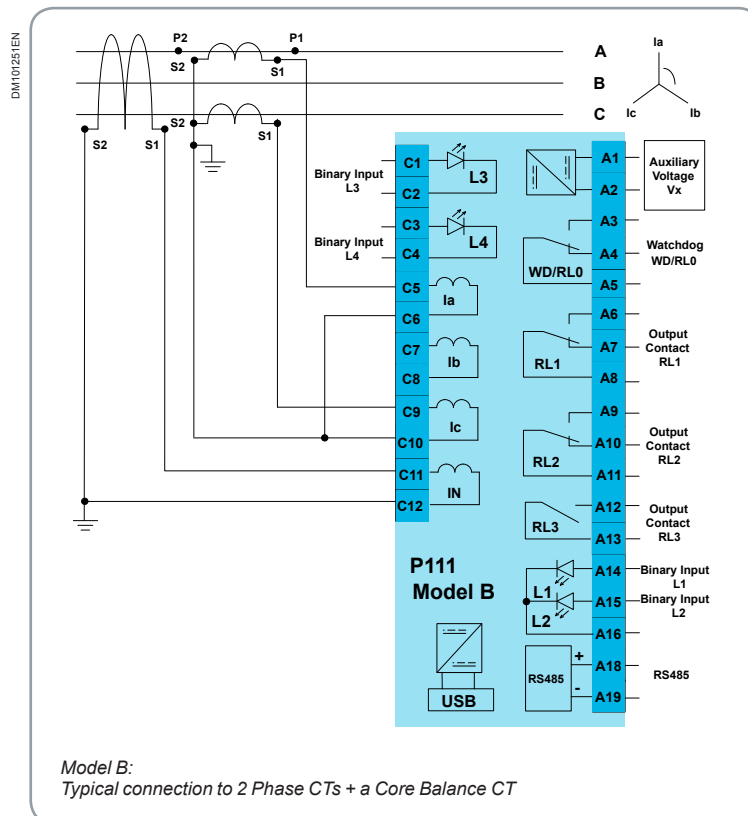
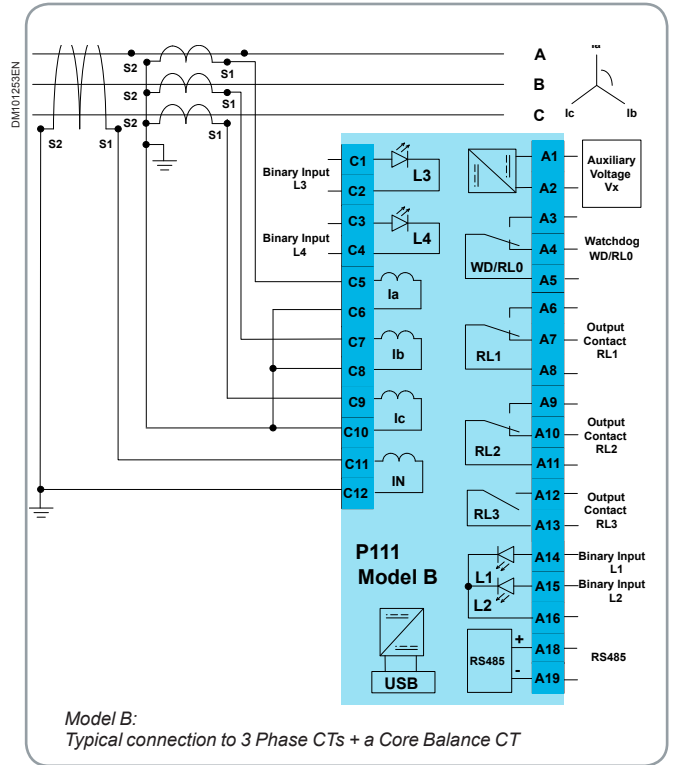
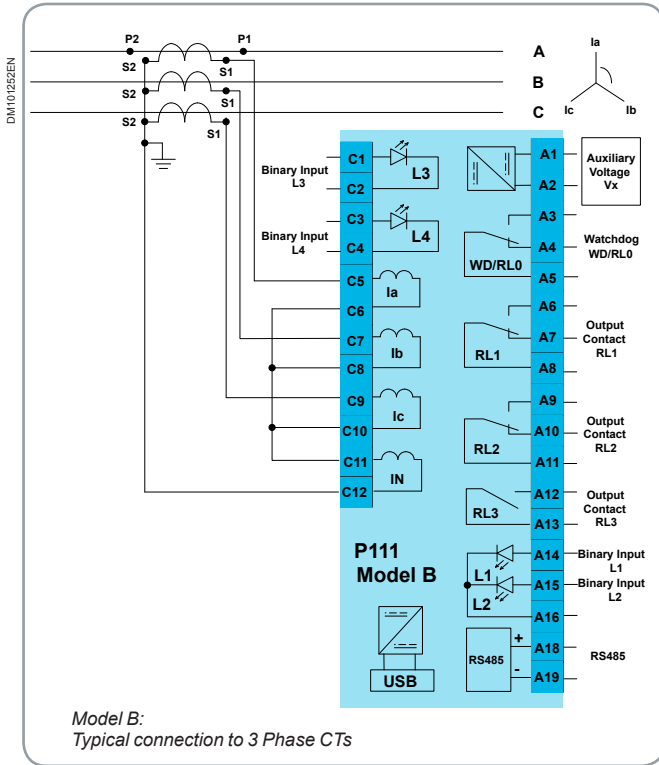

2

(cont.)

Model A external connection diagrams

2

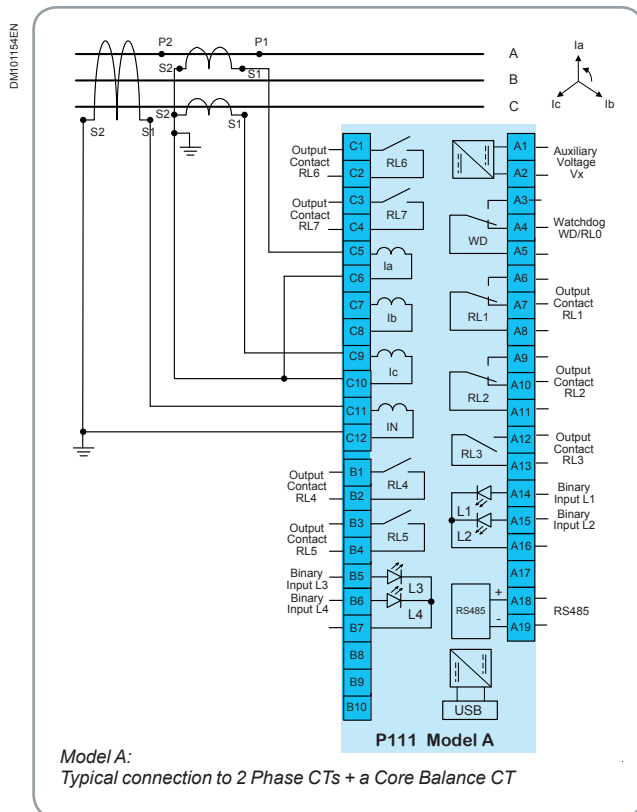
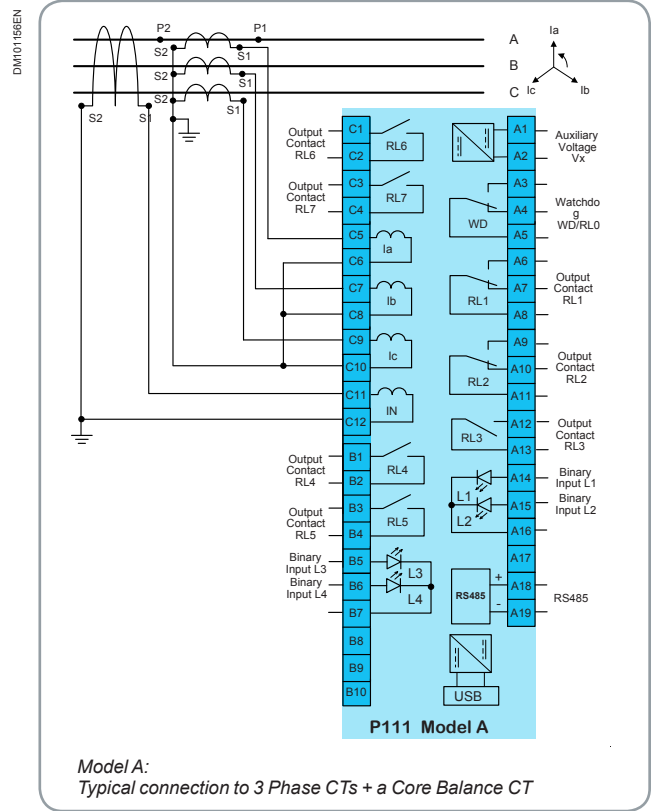
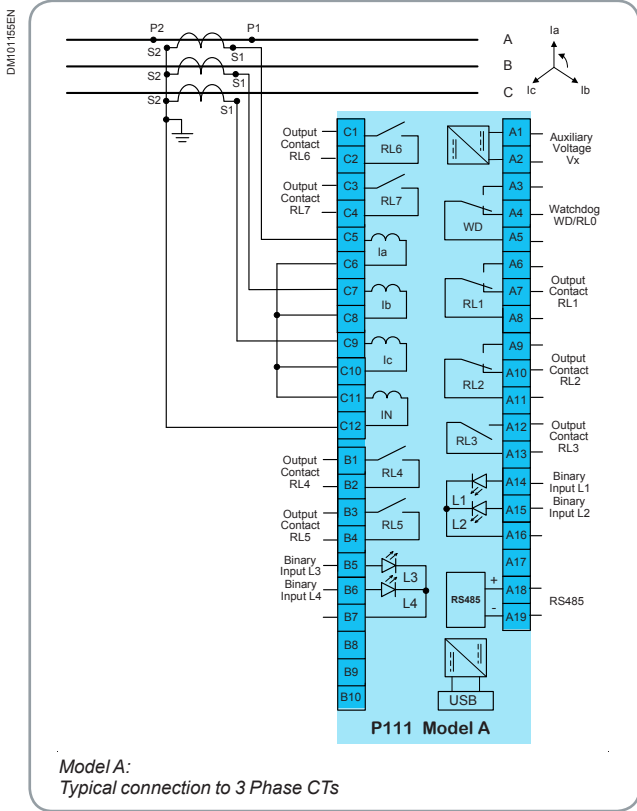

(cont.)

Model E external connection diagrams

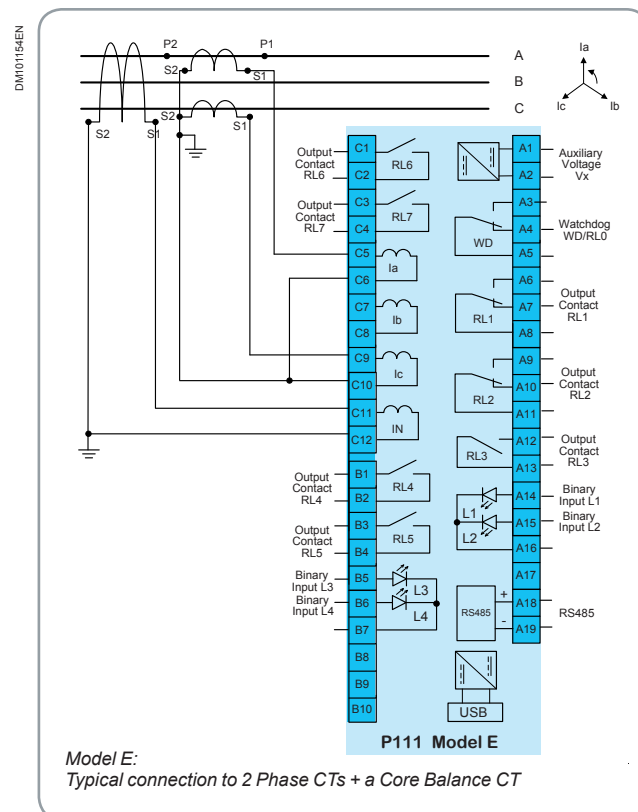
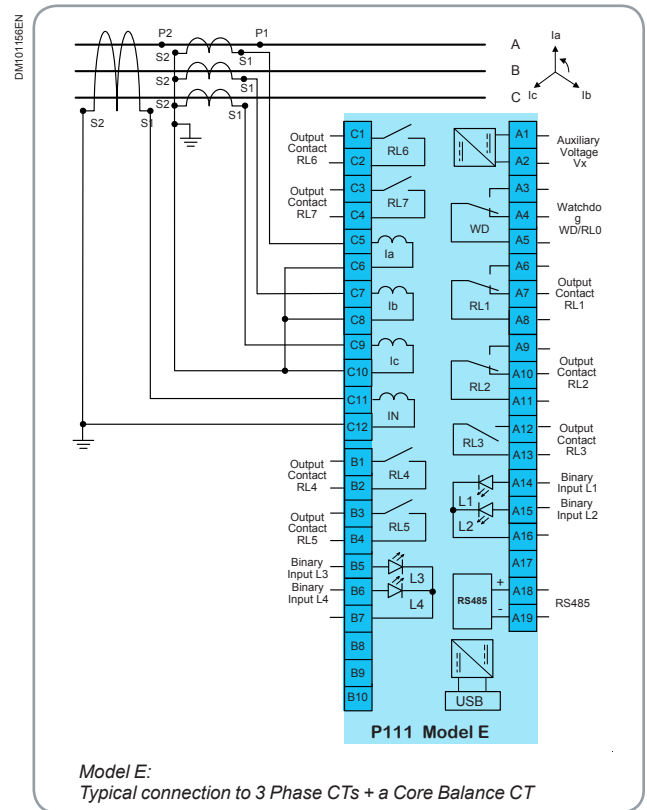
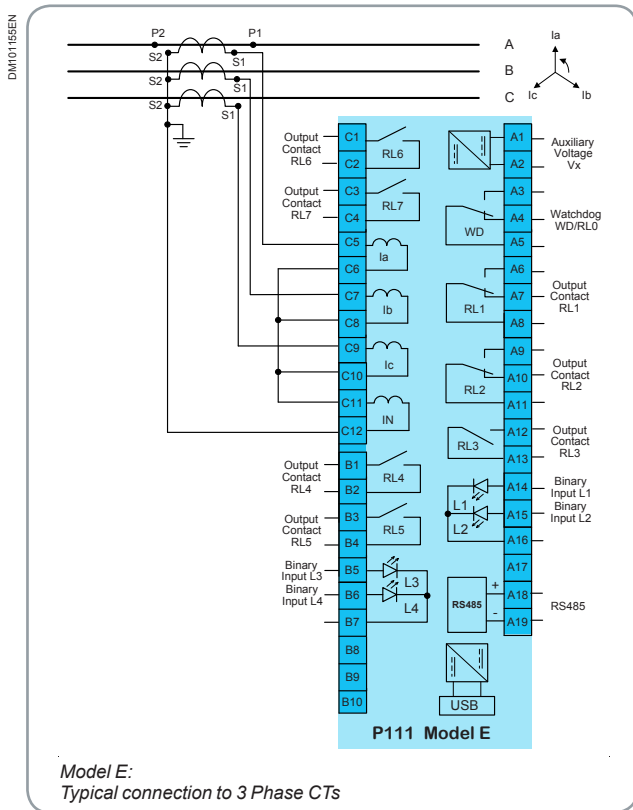

2

MiCOM P115

Numerical CT and auxiliary voltage powered overcurrent relays description

PM103829



2

MiCOM P115: A part of SCADA system today or in the future

Customer benefits

- No need of guaranteed auxiliary power supply
- Small dimensions of relay
- USB port for local communication with self-powering facilities
- Excellent for retrofit of old technology relays
- FRAM memory: no back-up battery inside



MiCOM P115 are numerical relays designed to offer overcurrent and earth fault protection without requiring any external auxiliary supply.

They can be applied to medium and high voltage electrical systems as either main or backup protection.

MiCOM P115 can be ordered in self-powered or in a dual-powered version.

P115 can be fully configured manually, without using of setting software.

MiCOM S1 Studio setting software allows via USB port to customize configuration parameters to specific application.

The relay offers additional measurement, monitoring and recording function available via communication port.

A capacitance discharge output capable of putting out sufficient power to a low energy trip coil of circuit breaker of MiTOP.

An external flag indicator F110 (SE) is used for remote or local indication that a trip has occurred.

Rear RS485 port allows to control of CB (with close and trip command).

Housed in optional Flush or Wall mounting metal case, it can be easily adapted to various applications.

Application

MiCOM P115 numerical overcurrent protection relays provide optimized and cost efficient solution where no external auxiliary power supply is available or guaranteed.

- Typical applications are:
 - A cost optimized MV switchboard with small dimensions
 - HV back up protection (HV/MV transformers)
 - Utility and industrial substations
 - Retrofit of old technology relays.

Global functions

The power supply to the electronic circuits of the MiCOM P115 has been optimised so that it can trigger the circuit breaker of MiTOP with a load current of 0.2 In on at least one phase.

The following functions are generally available:

- CT powered
- Ordering option: 1A and 5A with possibility to order different nominal current for phase and earth fault inputs
- Two types of case (HxWxD): flush (183x160x107) or wall (203x138x95) mounting
- Settings referred to nominal current.

Main functions

The hardware architecture and software algorithms have been studied to operate on very short failure detection times.

P115 relay is optional equipped with circuit breaker trip output (12-24Vdc, 0.1J CB coil or MiTOP). A capacitance discharge output capable of putting out sufficient power to low energy trip CB coil.

Thanks of changeover outputs and self-supplying facility P115 can be used in tripping current transformer application (current tripping CB coil).

An external Flag Indicator can be connected to independent energy output (24VDC, 0.01J)

Communication via USB (Modbus RTU protocol) and rear RS485 port (Modbus RTU or IEC 103 protocol) allows to download information about settings, measurements and inputs, outputs, starting, tripping, LEDs status.

IDMT (IEC, IEEE, US) time characteristics can be with instantaneous, time delayed or IDMT reset.

Power supply

AC Measuring Inputs				
Nominal frequency of fundamental harmonic (fn)	50 to 60 Hz			
Operating range of fundamental harmonic	40 to 70 Hz			
Phase current				
Nominal current (In)	1 or 5 A (ordering option)			
RMS measurement in range	40 Hz -1 kHz			
Nominal burden per phase	<ul style="list-style-type: none"> ■ In=1A: < 2.5 VA at In ■ In=5A: < 3 VA at In 			
Thermal withstand	<ul style="list-style-type: none"> ■ for 1 s: 100 In ■ for 10 s: 30 In ■ continuous: 3 In 			
Earth fault current				
Nominal current (Ien)	1 or 5 A (ordering option)			
RMS measurement in range	40 Hz -70 Hz			
Nominal burden	<ul style="list-style-type: none"> ■ In=1A: < 2.5 VA at Ien ■ In=5A: < 3 VA at Ien 			
Thermal withstand	<ul style="list-style-type: none"> ■ for 1 s: 100 Ien ■ for 10 s: 30 Ien ■ continuous: 3 Ien 			
Minimum level of current required for relay powering				
Phase current	<0.2In, approx. <ul style="list-style-type: none"> ■ one phase: 0.17 In ■ two phases: 0.1 In ■ three phases: 0.06 In 			
Earth fault current	<0.2 Ien, approx. 0.17 Ien			
<i>Note: depends on connection to the terminals, the earth fault input supplies P115 (connection: terminals 7 and 9) or does not supply P115 (connection: terminals 8 and 9) (refer to Installation chapter: User's manual P115/EN IN)</i>				
Nominal Auxiliary Voltage Vx				
Two ordering options	<ul style="list-style-type: none"> ■ Vx: 24 to 48 Vdc, and 24 to 48 Vac (50/60 Hz) ■ Vx: 60 to 250 Vdc, and 60 to 240 Vac (50/60 Hz) 			
Operating Range				
With a tolerable ac ripple of up to 12% for a dc supply, per IEC 60255-11: 1979	<ul style="list-style-type: none"> ■ 19 to 58 V (dc), 19 to 53V (ac) ■ 48 to 300 V (dc), 48 to 265 V (ac) 			
Nominal Burden - Auxiliary Power Supply Vx (Initial position: no output nor LED energized / Active position: all outputs and LEDs energized)				
Maximum (approx.)	Vx		S - VA	
	24-48Vac	24	Initial position	Active position
		48	3.1	5.5
	60-240Vac	48	2.4	6.0
		60	2.6	5.5
		100/110	2.7	5.2
		220/230	3.1	5.7
264		5.1	7.4	
24-48Vdc and 60-250Vdc		6.1	8.4	
		1.5 W	3.7 W	
Power-up Time for Auxiliary Supply Voltage only (not powered by CT)			< 0.04 s	
Auxiliary Power Supply Voltage Interruption (without powering by CT)				
IEC 60255-11: 1979	The relay will withstand a 50 ms interruption of the DC auxiliary supply within the auxiliary supply range, without de-energizing.			
EN 61000-4-11: 1997	The relay will withstand a 50 ms interruption in an AC auxiliary supply, without de-energizing.			

Inputs

Binary inputs : The binary inputs can be powered with both DC and AC voltage as binary input control voltage

Binary input type	Optically isolated
Rated nominal voltage	the same as Vx
Operating range	the same as Vx
Withstand	300 Vdc or 275 Vac

Nominal pick-up and reset thresholds

	Vx=24-48Vac/dc	■ Pick-up ■ Reset	approx. 12 Vdc approx. 11 Vdc
For DC	Vx=60-240Vac/dc	■ Pick-up ■ Reset	approx. 21 Vdc approx. 20 Vdc
	Vx=24-48Vac/dc	■ Pick-up ■ Reset	approx. 16 Vac approx. 11 Vac
For AC	Vx=60-240Vac/dc	■ Pick-up ■ Reset	approx. 26 Vac approx. 19 Vac

Recognition time <20 ms

Energy consumption of binary inputs

Resistance of binary inputs

- 24 to 48 Vac/dc: 5,5 kΩ ± 5%
- 60 to 240 Vac/dc: 100 kΩ ± 5%

For 220Vdc: $(220 \text{ Vdc})^2 \times 100 \text{ k}\Omega \pm 5\% = 0.484 \text{ W } \%$

Output contacts

General purpose relay outputs for signaling, tripping and alarming

Rated voltage	250 V	
Continuous current	5 A	
Short-duration current	25 A for 3 s	
Making capacity	150 A for 30 ms	
Breaking capacity	DC	50 W resistive
		25 W inductive (L/R = 40 ms)
	AC	1250 VA resistive (cos φ = unity)
		1250 VA inductive (cos φ = 0.7)
Response to command	< 10 ms	
Durability	Loaded contact	10 000 operations minimum
	Unloaded contact	100 000 operations minimum

Measured Data Acquisition

Reference Conditions: Sinusoidal signals with			<ul style="list-style-type: none"> ■ nominal frequency f_n ■ total harmonic distortion $\leq 2\%$ ■ ambient temperature $20\text{ }^\circ\text{C}$ ■ nominal auxiliary voltage V_x.
Operating Data	For current up to $3 I_n$ (Ien)	Phase and earth current	$\pm 3\%$
		Asymmetry current	$\pm 5\%$
Fault Data	For current $\leq 3 I_n$ (Ien)	Phase and earth current	$\pm 5\%$
	For current $> 3 I_n$ (Ien)		$\pm 5\%$



Protection functions

Operation time		
Typical operation time, if the P115 is supplied from V_x or if the current is above $0.2 I_n$ (Ien)		$\leq 40\text{ms}$
If the pre-fault current is below $0.2 I_n$ (Ien) in all phases and that there is no V_x on the 11 -12 terminals, additional time correction should be applied for the operation time (measured on the outputs contacts)		
The correction time measured on energy outputs is 6ms shorter than that measured on output contacts		
Hardware ver. P115746x0xxxxxx (without energy output for low energy tripping coil)		
■ For all types of fault (1, 2, 3-phases)		$\leq 25\text{mA}$
■ 1-phase fault, where the current is below $1.6 I_n$ (Ien)		$\leq 30\text{mA}$
Hardware ver. P115746x1xxxxxx (with energy output for low energy tripping coil 24VDC 0.1Ws)		
■ For faults where the current is $\leq 0.6 I_n$	■ 1-phase fault	Ien: $\leq 60\text{ms}$
	■ 2-phase fault	Ien: $\leq 60\text{ms}$
	■ 3-phase fault	Ien: $\leq 30\text{ms}$
■ For all types of fault where the current is $> 0.6 I_n$	■ 1, 2, 3-phases	Ien: $\leq 30\text{ms}$
<i>Note: The tripping time in case of a fault if the pre-fault current is below $0.2 I_n$ and there is no auxiliary voltage (V_x) on terminals 11 -12 is the sum of the set time delay, the operation time and the correction time.</i>		

Protection accuracy

All data are given for inception of fault from currents above 0.2 In (Ien) at least in 1 phase or if the P115 is powered from the Vx auxiliary voltage supply.
If the pre-fault current is below 0.2 In (Ien) in all phases and that there is no Vx on terminals 11 -12 additional time correction should be taken into account

**Reference Conditions:
Sinusoidal signals with**

- nominal frequency fn
- total harmonic distortion ≤2 %
- ambient temperature 20 °C
- nominal auxiliary voltage Vx.

Three-Phase Overcurrent I>, I>>

Pick-up	temperature range -20°C to +60°C	±5%
	temperature range -40°C to +85°C	±7.5%
Drop-off		0.95 x setting ±5%
Minimum IDMT level		1.05 x setting ±5%
IDMT curve		±7.5% or 30 ms whichever is greater
DT operation		±2% or 30 ms, whichever is greater
DT reset		±7.5% or 30 ms, whichever is greater

Three-Phase Overcurrent I>>>

Pick-up	temperature range -20°C to +60°C	±5%
	temperature range -40°C to +85°C	±7.5%
Drop-off		0.95 x setting ±5%
DT operation		±2% or 30 ms, whichever is greater
DT reset		±7.5% or 30 ms, whichever is greater

Earth Fault IN>

Pick-up	temperature range -20°C to +60°C	±5%
	temperature range -40°C to +85°C	±7.5%
Drop-off		0.95 x setting ±5%
Minimum IDMT level		1.05 x setting ±5%
IDMT curve		±7.5% or 30 ms whichever is greater
DT operation		±2% or 30 ms, whichever is greater
DT reset		±7.5% or 30 ms, whichever is greater

Earth Fault IN>>

Pick-up	temperature range -20°C to +60°C	±5%
	temperature range -40°C to +85°C	±7.5%
Drop-off		0.95 x setting ±5%
DT operation		±2% or 30 ms, whichever is greater
DT reset		±10% or 30 ms, whichever is greater

Assymetry overcurrent protection

Measurement criteria based on the maximum deviation of the phase current to the average value of the three-phase current

Pick-up	temperature range -20°C to +60°C	±5%
	temperature range -40°C to +85°C	±7.5%
Drop-off		0.95 x setting ±5%
DT operation		±2% or 30 ms, whichever is greater
DT reset		±7.5% or 30 ms, whichever is greater

2

Functional overview

(Description of ANSI code nos., see Protection Functions Table)

DN100116BEN

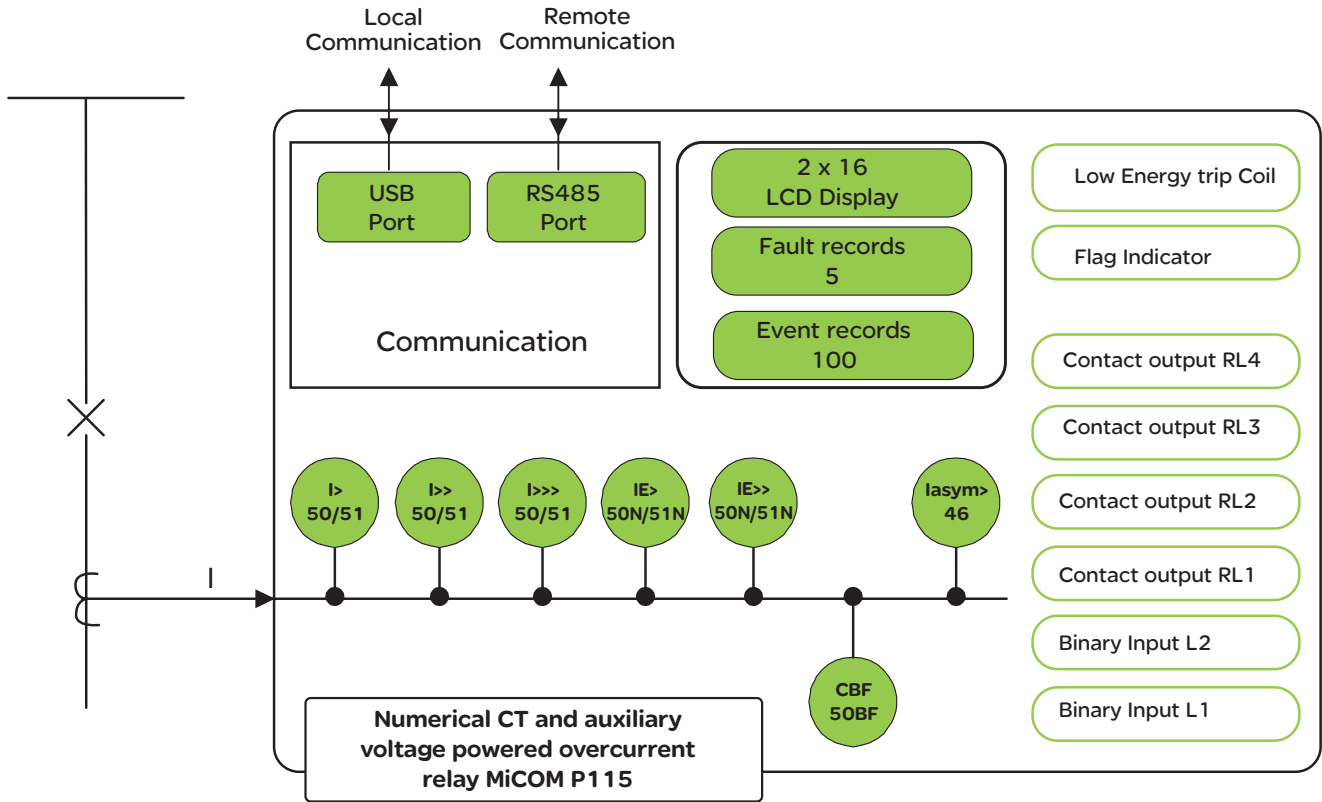

ANSI Code	Functions
	Powering from auxiliary supply voltage (ordering option)
50/51	Three-phase overcurrent I>>> (DT) Three-phase overcurrent I>> with DT or IDMT (IEC SI, VI, EI, UK LTI, STI, RI, IEEE: MI, VI, EI, US: CO2, CO8) Three-phase overcurrent I> with DT or IDMT (IEC SI, VI, EI, UK LTI, STI, RI, IEEE: MI, VI, EI, US: CO2, CO8)
50N/51N	Earth fault overcurrent IN>> (DT) Earth fault overcurrent IN> with DT or IDMT (IEC SI, VI, EI, UK LTI, STI, RI, IEEE: MI, VI, EI, US: CO2, CO8) Asymmetry overcurrent Iasym> (DT) Circuit Breaker Failure protection (CBF) with undercurrent criteria Instantaneous / IDMT delayed reset for IEC, IEEE and US characteristics Two settings group Blocking logic and selective relay scheme logic (*) External Trip or Alarm via Binary Input (timers: AUX1 and AUX2) (*) Changeover contacts output for current trip coil (RL1 and RL2) Output for low energy CB coil (12-24Vdc /0.1J) or MiTOP (ordering option) Output for Flag Indicator (24V, 0.01J) Up to 4 Binary Contacts (RL1, RL2, RL3, RL4) 8 signalling LEDs (6 freely configured) (*)
86	Output relay latching (*) Two Binary Opto Isolated Inputs (L1, L2) (*) Freely I/O configuration Fault records for the 5 most recent trips Event records (up to 100 events) Front USB port for local downloading of settings, events and/or fault records with self supplying facilities Rear port RS485 communications (Modbus RTU or IEC103) (*) Measurements (true RMS) available via communication port and LCD display (*) Setting software MiCOM S1 Studio

(*): Function not available if auxiliary power supply fails

MiCOM P115

Protection functions

(cont.)

Three-Phase Overcurrent Protection (50/51)

MiCOM P115 relays provide three phase current inputs. Three independent stages are available (I>, I>>, I>>>).

For I> and I>> the user may independently select definite time delay or inverse time delay with different type of curves IDMT (IEC SI, VI, EI, UK LTI, STI, RI, Rect, IEEE: MI, VI, EI, US: CO2, CO8). I>>> can be configured with definite time only.

Earth Fault Overcurrent Protection (50N/51N)

MiCOM P115 relays provide two independent stages earth fault current input (IN> and IN>>).

For the first stage (IN>) the user may independently select definite time delay or inverse time delay with different type of curves IDMT (IEC SI, VI, EI, UK LTI, STI, RI, Rect, IEEE: MI, VI, EI, US: CO2, CO8).

The second stage (IN>>) can be with definite time only E/f input, depends on the way of connection (terminals), can supply or not supply P115.

Assymetry Overcurrent Protection

Asymmetry overcurrent stage (DT) is based on difference between phase currents and average current in three phases.

Circuit Breaker Failure (50BF)

The circuit breaker failure verifies the effective opening of CB by dedicated undercurrent threshold.

The CBF is used for tripping upstream circuit.

Two Setting Groups

Two setting group includes protection settings, output and LED configuration.

I/O Configuration

Every input and output can be freely configured to available functions (blocking of protection element, reset LED or outputs, start, trip of every protection element, etc).

Remote Trip via Binary Input

Opto isolated binary input can be freely configured to timers AUX1 or/and AUX2. Timers can be used for ALARM signalling or TRIP of circuit breaker. This function works if powering of relay is assured.

Blocking and Selective Scheme Logic

When the P115 relays are used in critical networks, management of protection relays must take surrounding devices into consideration. Two digital inputs can be independently configured to lock any combination of selected elements (i.e. current stages or AUX timers).

Fault and Event Recording

The last 5 faults and 100 logic events are stored in FRAM memory. All events are time stamped to 1ms.

MiCOM S1 Studio support software

Support Software MiCOM S1 Studio is available for the entire MiCOM family, including P115 relays. MiCOM S1 Studio is fully Windows™ compatible.

This Support Software allows to set all parameters in P115 or download settings parameters, fault and event records.

PC connection with P115 is available via USB port.

MiCOM P115

Control & Monitoring

The P115 is equipped with integral fault recording facilities suitable for analysis of complex system disturbances. Fault records can be read out by setting software MiCOM S1 Studio via the USB port accessible on the P115 front panel. The USB port offers a communications facility to the P115.

Communications can be established via the USB port even if the P115 is supplied neither by the CT nor by the auxiliary voltage.

Access to the USB port is protected by means of an elastomer cover.

Event records

The relay records and time tags up to 100 events and stores them in non-volatile FRAM memory. This enables the system operator to establish the sequence of events that occurred within the relay following a particular power system condition, switching sequence etc. When the available space is exhausted, the oldest event is automatically overwritten by the most recent.

The real time clock within the relay provides the time tag for each event, to a resolution of 1 ms.

The event records are available for remote viewing, via the communications ports RS485 or USB.

Relay alarm conditions

Any alarm conditions generated by the relays will also be logged as individual events.

Protection element trips

Any operation of protection elements, (a trip condition) will be logged as an event record, consisting of a text string indicating the operated element and an event value (this value is intended for use by the event extraction software, such as MiCOM S1 Studio).

Fault records

Each fault record is generated with time stamp.

The data is recorded for any relevant elements that operated during a fault, and can be viewed in each of the last 5 fault records:

Measurements

The relay produces a variety of directly measured power system quantities:

- IA, IB, IC - RMS values
- IN - measured fundamental harmonic only (E/F analogue input)
- Iasym - calculated maximal difference between phase current and average value from 3 phase current

MiCOM P115

Setting ranges

Protection functions setting ranges

Function	Setting range			Step
	Default	min.	max.	
[46] Asymmetry				
	Disabled	Disabled, Enable Trip, Enable Alarm		N/A
lasym> ?	<ul style="list-style-type: none"> ■ Setting for Disable or enable of asymmetry element. ■ It is possible to enable for tripping CB (Enable Trip) or enable for an Alarm signal only (Enable Alarm) ■ If the protection element is "Enable Trip" configured it means that it is set to the General Trip Command ("Protect. Trip"), which can be used in I/O configuration ■ If the protection element is "Enable Alarm" it means that it is set to the General Alarm Command ("Alarm"), which can be used in I/O configuration. 			
lasym> Threshold	0.2 x In	0.08 x In	4 x In	0.01 x In
	■ Pick-up setting for the asymmetry overcurrent element.			
tlasym	10 s	0 s	200 s	0.01 s
	■ Setting for the operating time-delay for the asymmetry overcurrent element			
[50BF] Circuit breaker failure				
CBF ?	Disabled	Disabled, Enable Trip, Enable Alarm		
	■ Setting to enable or disable the circuit breaker supervision function.			
CB Fail Time tBF	0.2 s	0 s	10 s	0.01 s
	■ Setting for the circuit breaker fail timer stage for which the initiating condition must be valid.			
I< Threshold CBF	0.1 x In	0.05 x In	4 x In	0.01 x In
	■ Setting that determines the circuit breaker fail timer reset current for overcurrent based protection circuit breaker fail initiation.			
IN< Threshold CBF	0.1 x len	0.01 x len	2 x len	0.01 x len
	■ Setting that determines the circuit breaker fail timer reset current for earth fault current based protection circuit breaker fail initiation.			
	■ For dynamic range (ordering option): 0.01-2len, where len: nominal current for e/f input			
IN< Threshold CBF	0.1 x len	0.05 x len	2 x len	0.01 x len
	■ Setting that determines the circuit breaker fail timer reset current for earth fault current based protection circuit breaker fail initiation			
	■ For dynamic range (ordering option): 0.05-10len, where len: nominal current for e/f input			
IN< Threshold CBF	0.1 x len	0.05 x len	4 x len	0.01 x len
	■ Setting that determines the circuit breaker fail timer reset current for earth fault current based protection circuit breaker fail initiation.			
	■ For dynamic range (ordering option): 0.2-40len, where len: nominal current for e/f input.			



MiCOM P115

Setting ranges

(cont.)

Function	Setting range			Step
	Default	min.	max.	
[50N/51N] Earth/Ground fault				
	Disabled	Disabled, Enable Trip, Enable Alarm		
IN> ?	<ul style="list-style-type: none"> ■ Setting for Disable or enable of protection element. ■ It is possible to enable for tripping CB (Enable Trip) or enable for an Alarm signal only (Enable Alarm). ■ If the protection element is "Enable Trip" configured it means that it is set to the General Trip Command ("Protect. Trip"), which can be used in I/O configuration. ■ If the protection element is "Enable Alarm" it means that it is set to the General Alarm Command ("Alarm"), which can be used in I/O configuration. 			
IN> Threshold	0.1 x len	0.01 x len	0.2 x len	0.01 x len
	<ul style="list-style-type: none"> ■ Pick-up setting for first stage e/f overcurrent element. ■ For dynamic range (ordering option): 0.01-2len, where len: nominal current for e/f input. 			
IN> Threshold	0.5 x len	0.05 x len	1.0 x len	0.01 x len
	<ul style="list-style-type: none"> ■ Pick-up setting for first stage overcurrent element. ■ For dynamic range (ordering option): 0.05-10len, where len: nominal current for e/f input. 			
IN> Threshold	1 x len	0.2 x len	4.0 x len	0.01 x len
	<ul style="list-style-type: none"> ■ Pick-up setting for first stage e/f overcurrent element. ■ For dynamic range (ordering option): 0.2-40len, where len: nominal current for e/f input. 			
Delay Type IN>	IEC SI	DMT, IEC SI, IEC VI, IEC EI, UK LTI, UK STI, UK RC, RI, IEEE MI, IEEE VI, IEEE EI, US CO2, US CO8		
	<ul style="list-style-type: none"> ■ Setting for the tripping characteristic for the first stage e/f overcurrent element. 			
tIN>	1 s	0.02 s	200 s	0.01 s
	<ul style="list-style-type: none"> ■ Setting for the time-delay for the definite time setting if selected for first e/f stage element. 			
IN> TMS	1 s	0.02 s	1.6 s	0.01 s
	<ul style="list-style-type: none"> ■ Setting for the time multiplier setting to adjust the operating time of the IEC, UK, and RI IDMT characteristic. 			
IN> Time Dial	1 s	0.02 s	200 s	0.01 s
	<ul style="list-style-type: none"> ■ Setting for the time multiplier setting to adjust the operating time of the IEEE/US IDMT curves. 			
Reset Delay Type IN>	DMT	DMT or IDMT		
	<ul style="list-style-type: none"> ■ Setting to determine the type of reset/release characteristic of the IEEE/US curves. 			
DMT tReset IN>	0 s	0 s	200 s	0.01s
	<ul style="list-style-type: none"> ■ Setting that determines the reset/release time for definite time reset characteristic. 			
	Disabled	Disabled, Enable Trip, Enable Alarm		
IN>> ?	<ul style="list-style-type: none"> ■ Setting for Disable or enable of protection element. ■ It is possible to enable for tripping CB (Enable Trip) or enable for an Alarm signal only (Enable Alarm). ■ If the protection element is "Enable Trip" configured it means that it is set to the General Trip Command ("Protect. Trip"), which can be used in I/O configuration. ■ If the protection element is "Enable Alarm" it means that it is set to the General Alarm Command ("Alarm"), which can be used in I/O configuration. 			
IN>> Threshold	0.5 x len	0.01 x len	2.0 x len	0.01 x len
	<ul style="list-style-type: none"> ■ Pick-up setting for second stage of the e/f overcurrent element. ■ For dynamic range (ordering option): 0.01-2len, where len: nominal current for e/f input. 			
IN>> Threshold	2.5 x len	0.05 x len	10.0 x len	0.01 x len
	<ul style="list-style-type: none"> ■ Pick-up setting for second stage of the overcurrent element. ■ For dynamic range (ordering option): 0.05-10len, where len: nominal current for e/f input. 			
IN>> Threshold	5 x len	0.2 x len	40.0 x len	0.1 x len
	<ul style="list-style-type: none"> ■ Pick-up setting for second stage of the e/f overcurrent element. ■ For dynamic range (ordering option): 0.2-40len, where len: nominal current for e/f input. 			
tIN>>	0.1 s	0 s	200 s	0.01 s
	<ul style="list-style-type: none"> ■ Setting for the time-delay for the definite time setting if selected for this stage. 			

MiCOM P115

Setting ranges

(cont.)

2

Function	Setting range			Step
	Default	min.	max.	
[50/51] Phase overcurrent				
I> ?	Disabled	Disabled, Enable Trip, Enable Alarm		
	<ul style="list-style-type: none"> ■ Setting for Disable or enable of protection element. ■ It is possible to enable for tripping CB (Enable Trip) or enable for an Alarm signal only (Enable Alarm). ■ If the protection element is "Enable Trip" configured it means that it is set to the General Trip Command ("Protect. Trip"), which can be used in I/O configuration. ■ If the protection element is "Enable Alarm" it means that it is set to the General Alarm Command ("Alarm"), which can be used in I/O configuration. 			
I> Threshold	1.4 x In	0.2 x In	4.0 x In	0.01 x In
	■ Pick-up setting for first stage of the overcurrent element.			
I> Delay Type	IEC SI	DMT, IEC SI, IEC VI, IEC EI, UK LTI, UK STI, UK RC, RI, IEEE MI, IEEE VI, IEEE EI, US CO2, US CO8		
	■ Setting for the tripping characteristic for the first stage overcurrent element.			
tl>	1 s	0.02 s	200 s	0.01 s
	■ Setting for the time-delay for the definite time setting if selected for first stage element.			
I> TMS	1 s	0.02 s	1.6 s	0.01 s
	■ Setting for the time multiplier setting to adjust the operating time of the IEC, UK, and RI IDMT characteristic			
I> Time Dial	1 s	0.02 s	200 s	0.01 s
	■ Setting for the time multiplier setting to adjust the operating time of the IEEE/US IDMT curves.			
Reset Delay Type I>	DMT	DMT or IDMT		
	■ Setting to determine the type of reset/release characteristic of the IEEE/US curves.			
DMT tReset I>	0 s	0 s	200 s	0.01 s
	■ Setting that determines the reset/release time for definite time reset characteristic.			
I>> ?	Disabled Disabled, Enable Trip, Enable Alarm			
	<ul style="list-style-type: none"> ■ Setting for Disable or enable of protection element. ■ It is possible to enable for tripping CB (Enable Trip) or enable for an Alarm signal only (Enable Alarm). ■ If the protection element is "Enable Trip" configured it means that it is set to the General Trip Command ("Protect. Trip"), which can be used in I/O configuration. ■ If the protection element is "Enable Alarm" it means that it is set to the General Alarm Command ("Alarm"), which can be used in I/O configuration. 			
I>> Threshold	1.4 x In	0.2 x In	4.0 x In	0.01 x In
	■ Pick-up setting for second stage of the overcurrent element.			
Delay Type I>>	IEC SI	DMT, IEC SI, IEC VI, IEC EI, UK LTI, UK STI, UK RC, RI, IEEE MI, IEEE VI, IEEE EI, US CO2, US CO8		
	■ Setting for the tripping characteristic for this stage overcurrent element.			
tl>>	1 s	0.02 s	200 s	0.01 s
	■ Setting for the time-delay for the definite time setting if selected for this stage element.			
I>> TMS	1 s	0.02 s	1.6 s	0.01 s
	■ Setting for the time multiplier setting to adjust the operating time of the IEC, UK, and RI IDMT characteristic.			
I>> Time Dial	1 s	0.02 s	200 s	0.01 s
	■ Setting for the time multiplier setting to adjust the operating time of the IEEE/US IDMT curves.			
Reset Delay Type I>>	DMT	DMT or IDMT		
	■ Setting to determine the type of reset/release characteristic of the IEEE/US curves.			
DMT tReset I>>	0 s	0 s	200 s	0.01 s
	■ Setting that determines the reset/release time for definite time reset characteristic.			
I>>> ?	Disabled Disabled, Enable Trip, Enable Alarm			
	<ul style="list-style-type: none"> ■ Setting for Disable or enable of protection element. ■ It is possible to enable for tripping CB (Enable Trip) or enable for an Alarm signal only (Enable Alarm). ■ If the protection element is "Enable Trip" configured it means that it is set to the General Trip Command ("Protect. Trip"), which can be used in I/O configuration. ■ If the protection element is "Enable Alarm" it means that it is set to the General Alarm Command ("Alarm"), which can be used in I/O configuration. 			

MiCOM P115

Setting ranges

(cont.)

Function	Setting range			Step
	Default	min.	max.	
[50/51] Phase overcurrent				
I>>> Threshold	4 x I _n	0.2 x I _n	40.0 x I _n	0.1 x I _n
	<ul style="list-style-type: none"> ■ Pick-up setting for third stage of the overcurrent element. 			
tI>>>	0.1 s	0 s	200 s	0.01 s
	<ul style="list-style-type: none"> ■ Setting for the time-delay for the definite time setting if selected for this stage element. 			
AUX Timers				
	Disabled	Disabled, Enable Trip, Enable Alarm		
AUX1 ?	<ul style="list-style-type: none"> ■ Setting for Disable or enable of AUX1 element. ■ It is possible to enable for tripping CB (Enable Trip) or enable for an Alarm signal only (Enable Alarm) ■ If the protection element is "Enable Trip" configured it means that it is set to the General Trip Command ("Protect. Trip"), which can be used in I/O configuration. ■ If the protection element is "Enable Alarm" it means that it is set to the General Alarm Command ("Alarm"), which can be used in I/O configuration. 			
tAUX1	10 s	0 s	200 s	0.01 s
	<ul style="list-style-type: none"> ■ Setting for the operating time-delay for AUX1 function. 			
	Disabled	Disabled, Enable Trip, Enable Alarm		
AUX2 ?	<ul style="list-style-type: none"> ■ Setting for Disable or enable of AUX2 element. ■ It is possible to enable for tripping CB (Enable Trip) or enable for an Alarm signal only (Enable Alarm). ■ If the protection element is "Enable Trip" configured it means that it is set to the General Trip Command ("Protect. Trip"), which can be used in I/O configuration. ■ If the protection element is "Enable Alarm" it means that it is set to the General Alarm Command ("Alarm"), which can be used in I/O configuration. 			
tAUX2	10 s	0 s	200 s	0.01 s
	<ul style="list-style-type: none"> ■ Setting for the operating time-delay for AUX2 function. 			
Circuit Breaker				
tOpen Pulse min	0.5 s	0.01 s	10 s	0.01 s
	<ul style="list-style-type: none"> ■ Defines the duration of the trip pulse 			
tClose Pulse min	0.5 s	0.01 s	5 s	0.01 s
	<ul style="list-style-type: none"> ■ Defines the duration of the close pulse 			
tP pulse	5760 mn (4 days)	1 mn	65000 mn	1 mn
	<ul style="list-style-type: none"> ■ Defines the duration of the trip pulse. This pulse can be used for longer signaling of trips. <p><i>Note: E.g RL4 configured to this function can be used to switch on an auxiliary voltage supply after tripping, for a fixed period (for example four days). Thus ensuring communication and signaling facilities. After the fixed period Auxiliary Voltage can be disconnected from the P115's terminals automatically to save a substation battery.</i></p>			
CB not Healthy	16 s	1 s	200 s	1 s
	<ul style="list-style-type: none"> ■ If the circuit breaker does not indicate a healthy condition in this time period following a close command, then the relay will lockout and set off an alarm. 			

MiCOM P115

Base unit

PM103530



Presentation

User-Machine Interface (HMI)

All functions, including protection, automation, communication, LEDs, inputs and outputs, can be programmed and modified using the front panel user interface (Human Machine Interface).

The backlit LCD informs the user about settings, measurements & faults with a pull-down menu structure allowing easy and quick access to any data.

Working language

The relay display language can be changed in the menu system.

All the texts and messages displayed on HMI are available in 1 serie of languages:

- English/German/French/ Spanish/Polish

Wiring

Terminal block connections are made via screw terminals.

■ AC Current Input Terminals

Threaded M3 screw-type plug-in terminals, with wire protection for conductor cross-section

- 0.2 - 6mm² single-core
- 0.2 - 4mm² finely stranded

■ General Input/Output Terminals

For power supply, binary inputs, output contacts and COM for rear communications.

Threaded M3 screw-type plug-in terminals, with wire protection for conductor cross-section

- 0.2 - 4mm² single-core
- 0.2 - 2.5mm² finely stranded

Communication

Type Port	Physical Link	Connectors	Data Rate	Comms. mode	Protocol
RS485 (Rear communications port)	Screened twisted pair cables: multi-endpoint link max. 100 m	Screws or snap-on	<ul style="list-style-type: none"> ■ 4800 bauds or ■ 9600 bauds or ■ 19200 bauds 	<ul style="list-style-type: none"> ■ Data Bit: 8 ■ Stop bit: 1 or 2 ■ Parity: Even or Odd or no parity ■ Address: 1 to 254 	<ul style="list-style-type: none"> ■ Modbus RTU, IEC60870-5-103 (selectable in menu) Isolation to SELV level
USB	USB2.0	PC: type A male P115: type mini B male	115.2 kbits/s (fixed)	<ul style="list-style-type: none"> ■ Data Bit:8 ■ Stop bit: 1 ■ Parity: None ■ Address: 1 	<ul style="list-style-type: none"> ■ Modbus RTU

Dimensions & weight

P115 flush mounting case

Dimensions

- Height 183 mm
- Width 160 mm
- Depth 107 mm

Weight

- P115 approx.1 Kg

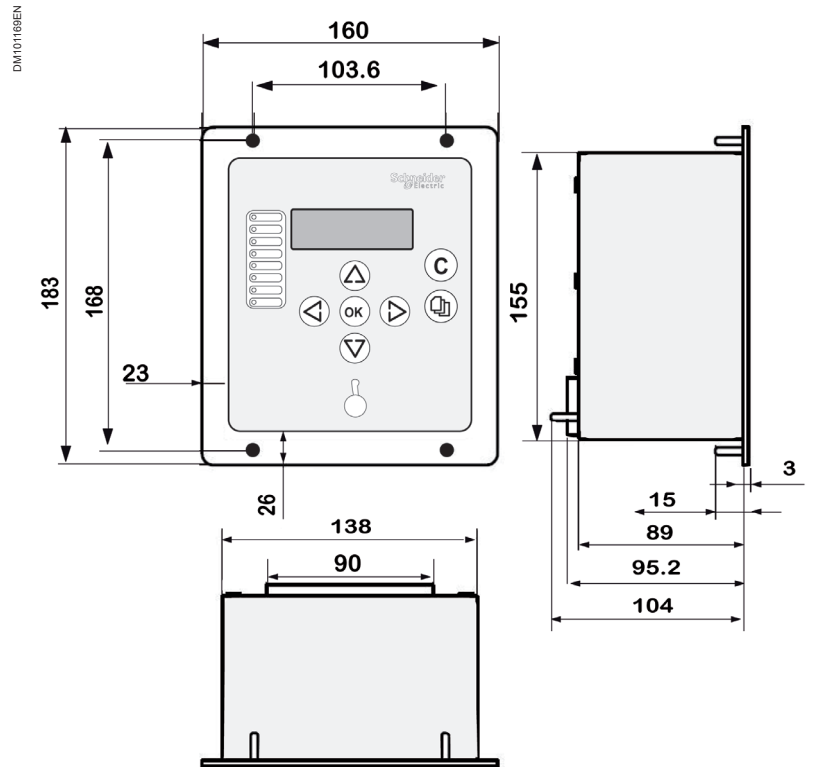

Front panel description

- 1 Green "Healthy" LED.
- 2 Red "Trip" LED Any trip of protection
- 3
- 4
- 5 Red programmable LED
- 6
- 7
- 8
- 9 16 character by 2-line alphanumeric liquid crystal display (LCD)
- 10 A clear key 1
- 11 A read key,
- 12 4 arrow keys, an enter key
- 13 USB port for local connection

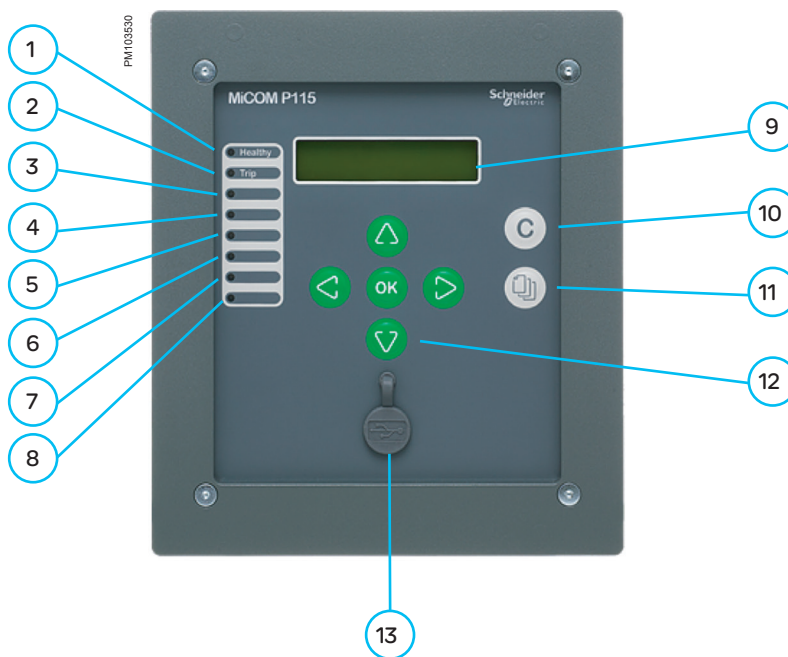

Rear panel description

- 14 3rd terminal block: Auxiliary voltage supply, Binary inputs, Binary outputs, Flag indicator energy output, Low energy trip coil
- 15 2nd terminal block: RS485
- 16 1st terminal block: phase and e/f current inputs
- 17 PCT Protective (Earth) Conductor terminal

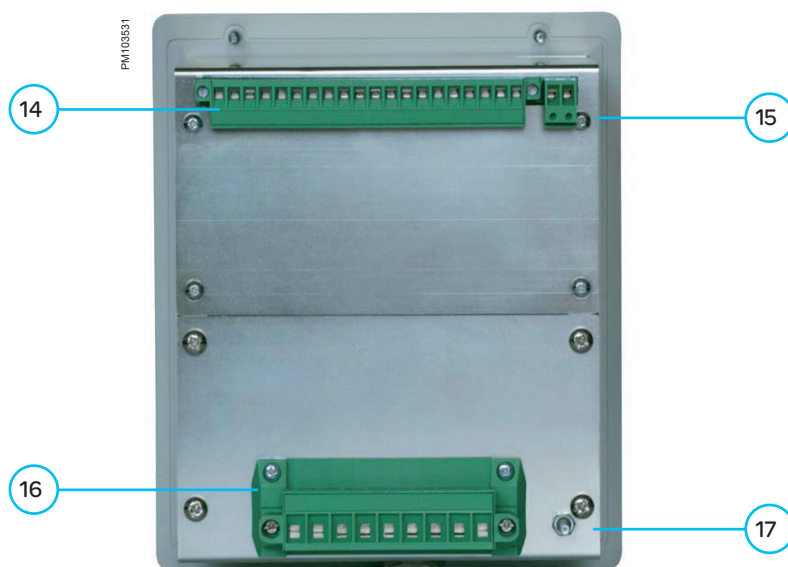

External connection diagrams

MiCOM P115:
Typical 3 phase CTs connection.

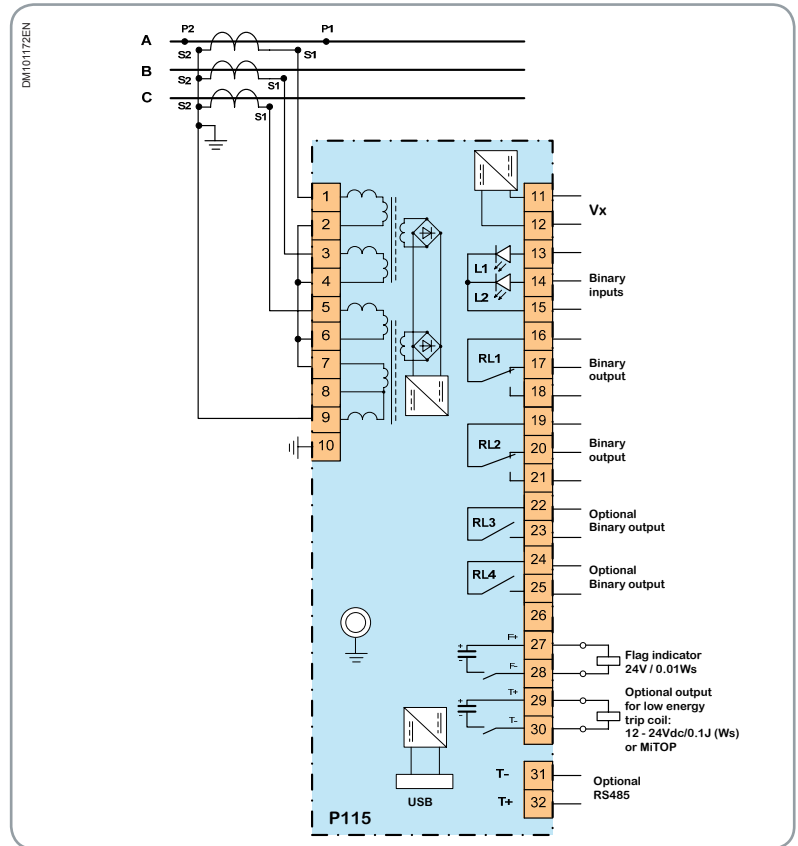

MiCOM P115:
Typical 3 phase CTs + Core balanced CT connection.
The P115 is not supplied via a Core Balance CT. An auxiliary voltage source should be connected to the 11-12 terminals in order to ensure that the P115 is supplied for earth fault currents below 0.2 In.

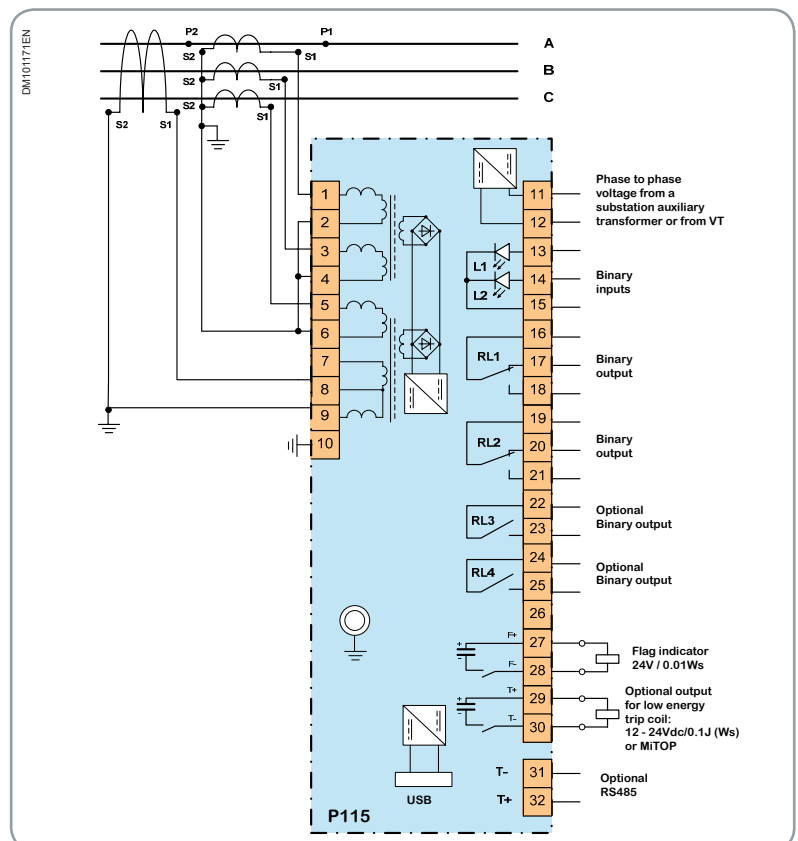

MiCOM P115

Base unit

(cont.)

2

MiCOM P115:

Typical 2 phase CTs + Core balanced CT connection.

The P115 is not supplied via a Core Balance CT. An auxiliary voltage source should be connected to the 11-12 terminals in order to ensure that the P115 is supplied for earth fault currents below 0.2 In.

If the phase to phase voltage can't be applied (11-12 terminals), a core balanced CT can be connected to 7-9 terminal to supply P115. But this application requires a Core Balanced CT which can provide enough energy to supply the P115.

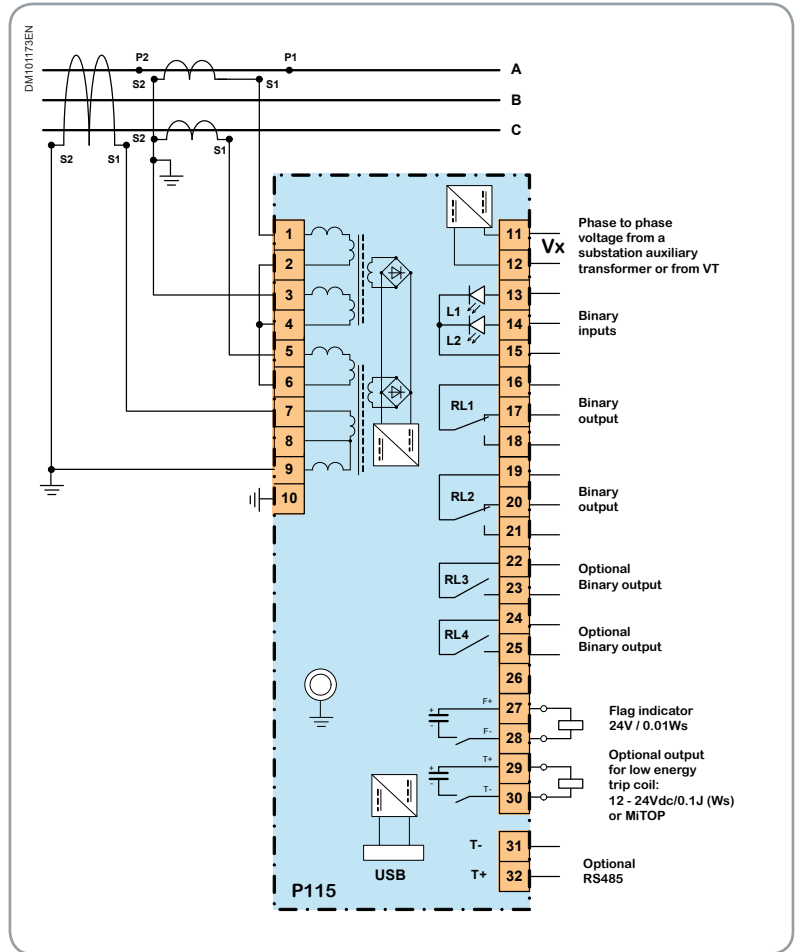

Application connection diagrams

MiCOM P115 powered by a WA 25 O / 2 pole:
 Connection example for a P115 powered by a WA 25 O and with a 2 pole connection (A - C)

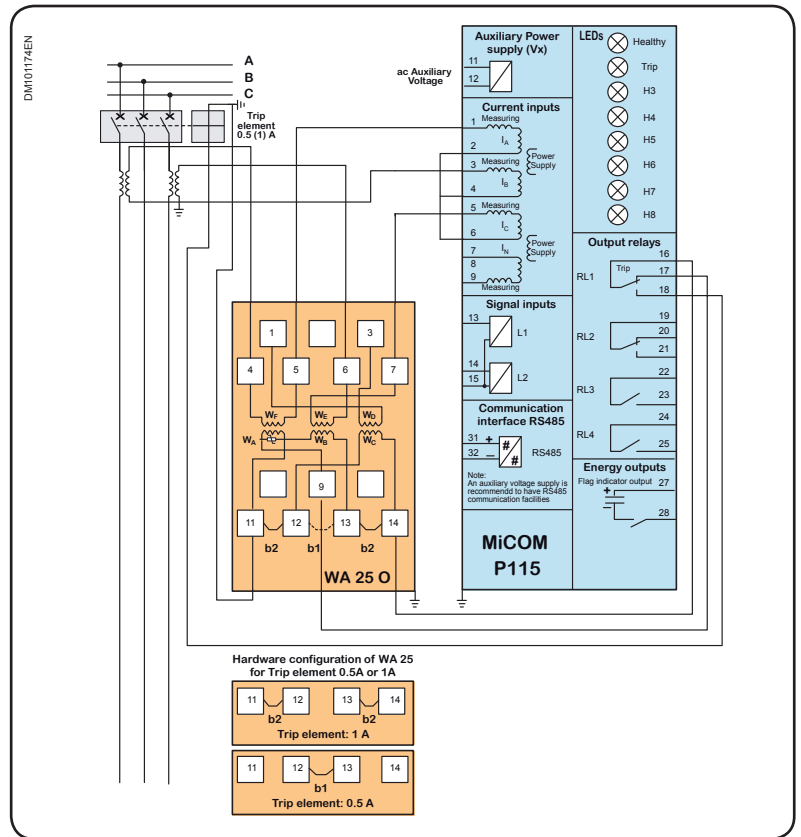

MiCOM P115 powered by a WA 25 O / 3 pole:
 Connection example for a P115 powered by a WA 25 O and with a 3 pole connection (A - B - C)

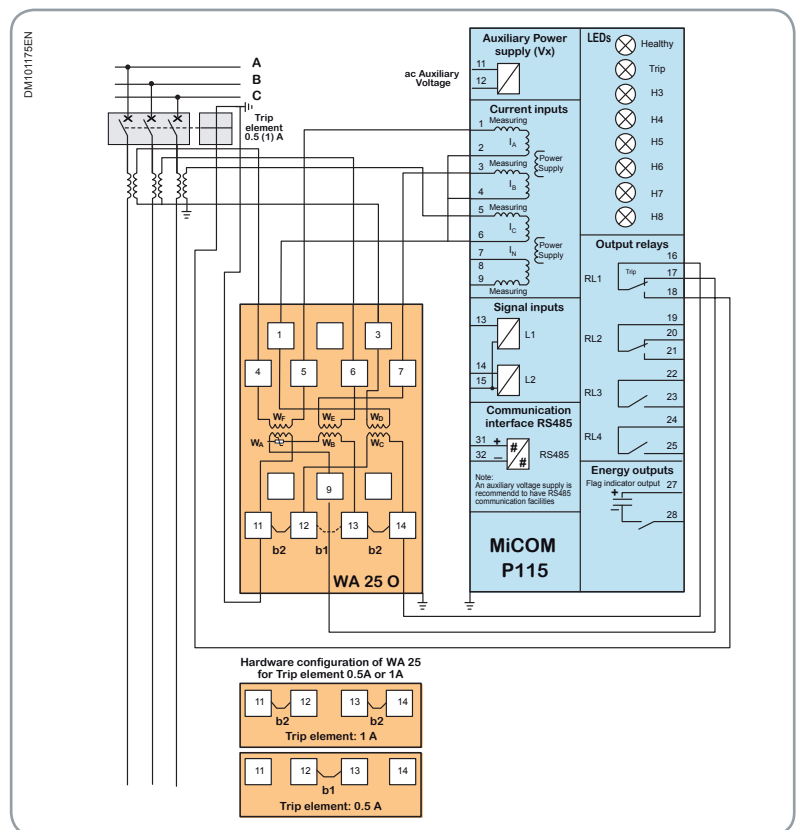

MiCOM P115

Base unit

(cont.)

2

MiCOM P115 powered by a WA 25 O / 4 pole:
 Connection example for a P115 powered by a WA 25 O and with a 4 pole connection (A - B - C - N)

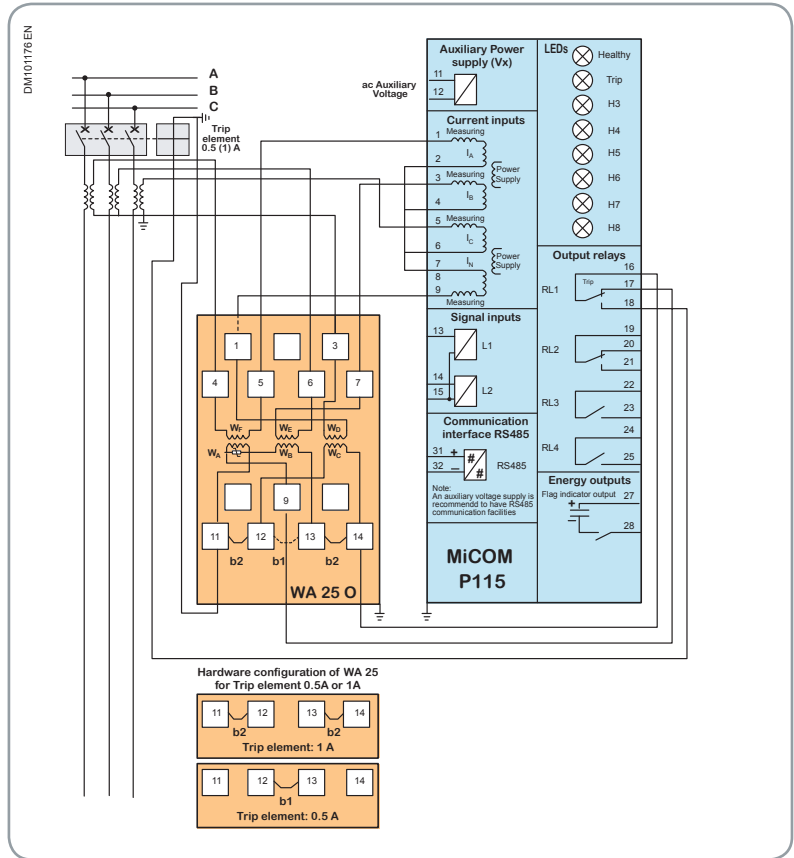

MiCOM P115 powered by a MiCOM E124 (4 pole)

Connection example for a P115 powered by an E124 and with a 4 pole connection (A - B - C - N).

The earth input supplies the relay.

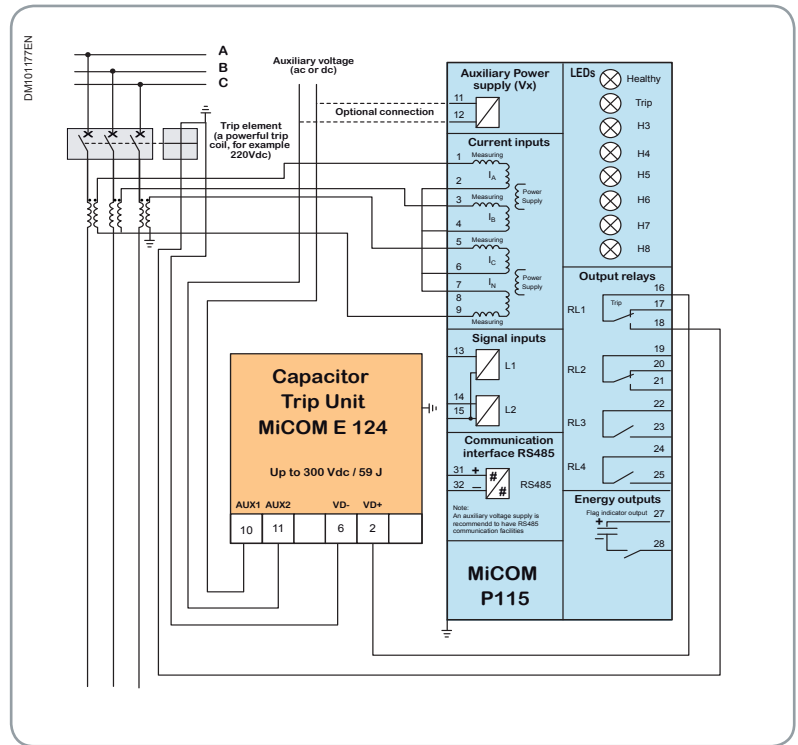

MiCOM P115 powered by a MiCOM E124 (4 pole)

Connection example for a P115 powered by an E124 and with a 4 pole connection (A - B - C - N).

The P115 is not supplied via the earth input.

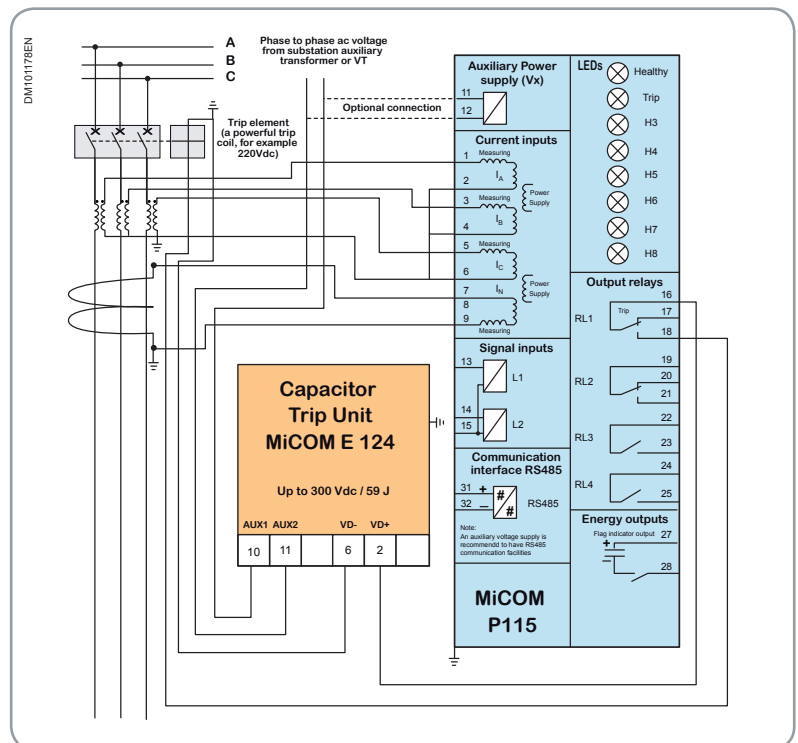

MiCOM P116

Numerical CT and Vx Auxiliary Voltage-Powered Overcurrent Relays



PM103595

2

MiCOM P116 are innovative CT-powered numerical relays for use anywhere, when auxiliary voltage is not available/guaranteed.

MiCOM P116 are numerical relays designed to offer overcurrent and earth fault protection without requiring a guaranteed external auxiliary supply.

They can be applied to medium and high voltage electrical systems as either main or backup protection.

When supervision functions are required, the dual-powered relay offers additional measurement, monitoring and recording functions.

The P116 can be fully configured manually, without using setting software. Alternatively, MiCOM S1 Studio setting software allows configuration parameters to be modified for a specific application via the USB port.

IEC 60870-5-103 and Modbus RTU integrated communication protocols are available for flexible integration into most substation control or DCS systems.

A capacitance discharge output is able to provide sufficient power to energise a circuit breaker's low energy trip coil or MiTOP. An external flag indicator is used for remote or local indication that a trip has occurred. Accessories such as low energy striker or capacitor trip unit are also available to fit your particular application.

For Flush or Wall Mounted applications, an optional secondary case is available for ease of installation.

Two hardware options are available:

- Model A (Dual powered)
- Model L (CT powered only)



Customer benefits

- No need for a guaranteed auxiliary power supply
- Small dimensions of relay
- USB port for local communication with self-powering facilities
- Additional measurement, monitoring, recording and communication features
- FRAM memory: Battery back-up not required

Application

The MiCOM P116 numerical overcurrent protection relays provide an optimized and cost efficient solution where no external auxiliary power supply is available or guaranteed.

Typical applications are:

- Utility and industrial substation fitted with cost-optimized MV switchboards
- HV back-up protection (HV/MV transformers)
- Retrofit relays of old technology, particularly during installation of DCS systems.

In addition to its protection functions and when powered by an external auxiliary supply, the dual-powered P116 is able to transmit recorded and measured data to a supervisor through communication networks. Should the auxiliary power supply (Vx) fail, protection and tripping functions remain fully operational.

MiCOM P116 relays draw the power necessary to their operation from the line's current transformers and/or the auxiliary voltage supply (Vx).

Main features

The power supply to the electronic circuits of the MiCOM P116 has been optimised so that it can trigger the circuit-breaker with a load current of 0.2 In on at least one phase. The scope of functionality depends on the following CT powering threshold:

- $(I1+I2+I3+IN) < 0.65 I_n$: all protection and recording functions, RL1, trip energy and flag indicators are active. But in order to save power – reduce the consumption of energy from the CTs (i.e. lower CT requirements), outputs contacts RL2-RL6, the LCD display, the LEDs and the RS485 port are switched off.
- $(I1+I2+I3+IN) > 0.65 I_n$: full functionality.

The front panel includes an electromagnetic bistable flag to indicate that a trip has occurred. As an option in the dual-powered P116, four additional magnetic indicator flags are configurable.

8 LEDs indicate the correct operation of the relay as well as other information regarding the protection of the electrical system.

The hardware architecture and software algorithms have been designed to operate on very short failure detection times. Tripping occurs typically within no more than 40 ms (for a switch-on-to-fault condition without Vx auxiliary voltage: typically 70 ms. This time includes 30 ms for P116 booting).

The standard flush mounting case is fitted with a CT circuit-shorting solution: a plug is built into some of the P116's terminals so that it is possible to withdraw only removable terminals even if the CB is closed and there are currents present.

For easier withdrawal of the P116 from the front of the switchgear panel, the standard P116 case can be fitted in an optional flush mounting secondary case (P116 accessories).

For wall- or plate-mounting of the P116, the wall-mounting cassette is used (P116 accessories).

Main functions

The circuit-breaker can be tripped using internal tripping energy (capacitor charge within the P116), drawn from the fault's energy (CTs) and/or from the auxiliary voltage.

The capacitor discharge energy from P116 is sufficient for energising a sensitive CB trip coil (12-24Vdc /0.1J), MiTOP, or a striker (P116 accessories), thus releasing the actuating mechanism of the circuit-breaker.

For legacy CB applications (not fitted with a sensitive CB coil) the trip command can be based on the energy stored in the microprocessor capacitor trip unit - MiCOM E124 (P116 accessories). A relay output can send a command directly to the standard circuit-breaker coil. This solution is easier to install than the striker solution, as no mechanical connection with the CB is required. However it is necessary to guarantee the auxiliary supply for charging of the E124. Approximately 1 minute of charge can ensure E124 is ready to operate for over 8 days.

E124 provides two independent capacitor banks.

If an auxiliary voltage (Vx): AC or DC, is available, redundant tripping commands can be executed using P116's relay contacts and substation auxiliary voltage.

MiCOM P116

Ratings



Power supply (Model A)	
Nominal auxiliary voltage V _x (ordering options)	<ul style="list-style-type: none"> ■ 24 – 60 Vdc/ 24 – 60 Vac (50/60 Hz) ■ 60 – 250 Vdc/ 60 – 240 Vac (50/60 Hz)
Operating range	<ul style="list-style-type: none"> ■ 19 – 72 V (dc), 19 – 66 V (ac) ■ 48 – 300 V (dc), 48 – 264 V (ac)
Tolerable AC ripple	Up to 12% for a dc supply, per IEC 60255-11: 2008

Nominal Burden - Auxiliary Power Supply V _x <i>(Initial position: no output nor LED energized / Active position: all outputs and LEDs energized)</i>				
	V _x (V)	S (VA)		
		Initial position	Active position	
For ac max. (approx.)	24 - 60 Vac	24	3.1	5.5
		48	2.8	6.0
		60	2.7	5.2
	60 - 240 Vac	100/110	3.1	5.7
		220/230	5.1	7.4
		264	6.1	8.4
For dc V _x voltage max. (approx.)	V _x (V)	P (W)		
		Initial position	Active position	
	24 - 60 Vac	1.5	3.7	
	60 - 240 Vac	1.5	3.7	

Auxiliary Power Supply Voltage Interruption (without powering by CT)	
IEC 60255-11: 2008	Within the auxiliary supply range: ■ 48-250Vdc, the relay will withstand a 50 ms ■ 24-48Vdc, the relay will withstand a 20 ms
EN 61000-4-11: 1997	Within the auxiliary supply range: ■ 48-250Vac, the relay will withstand a 50 ms ■ 24-48Vac, the relay will withstand a 20 ms

Power-up Time for Auxiliary Supply Voltage only (not includes charging of the energy outputs)	
Time to power up via auxiliary supply only (not powered by CT)	0.04 s

Current inputs	
Nominal Frequency	50 or 60 Hz (selectable in P116 menu)
Phase current inputs	
Nominal current (I _n)	1 or 5 A (ordering option)
RMS measurement in range	40 Hz – 1 kHz
Fundamental harmonic measurement in range	40 Hz – 70 Hz
Operating range	0.1 – 40 I _n
Nominal Burden at I _n (without tripping condition)	<ul style="list-style-type: none"> ■ < 2.3 VA (for I_n = 1 A) ■ < 2.1 VA (for I_n = 5 A)
Thermal withstand	<ul style="list-style-type: none"> ■ 1 s @ 100 x rated current ■ 2 s @ 40 x rated current ■ 10 s @ 30 x rated current ■ continuous @ 3 x rated current
Connection	Refer to section 12 of P116 Installation chapter (P116/EN IN)
Current transformer requirements	Detailed information and CT requirements are given in the Application chapter (P116/EN AP)
Earth current inputs	
Nominal current (I _{en})	1 or 5 A (ordering option)
Fundamental harmonic measurement in range	40 Hz – 70 Hz
Operating range	<ul style="list-style-type: none"> ■ 0.002-1 I_{en} ■ or 0.01-8 I_{en} ■ or 0.1 - 40 I_{en} (ordering option)
Nominal Burden at I _{en} (without tripping condition)	<ul style="list-style-type: none"> ■ < 2.3 VA (for I_{en} = 1 A) ■ < 2.1 VA (for I_{en} = 5 A)
Thermal withstand	<ul style="list-style-type: none"> ■ 1 s @ 100 x rated current ■ 2 s @ 40 x rated current ■ 10 s @ 30 x rated current ■ continuous @ 3 x rated current
Current transformer requirements	Detailed information and CT requirements are given in the P116 technical manual

Minimum Level of Current Required for Relay Powering

Phase current / Earth current with reduced functionality > 0.2 In in one phase

■ Active outputs: RL1, Trip electromagnetic flag and Energy output for sensitive CB coil).

■ LCD, LEDs, RL2-RL6, RS485, programmable electromagnetic flags are inactive

Phase current with full functionality

■ > 0.65 In in one phase
 ■ > $In = |\bar{I}A - \bar{I}B| + |\bar{I}C + \bar{I}N|$ ¹⁾

¹⁾ Powering of P116 from earth input is selectable by using proper terminals (A7-8: with powering or A9-10: without powering) and additionally by configuration in P116 menu (GLOBAL SETTINGS/CT RATIO/IN connection). Detailed information is given in the Setting chapter (P116/EN ST) and Installation chapter (P116/EN IN).

Note:

■ Depending on the terminal connections and configuration in menu, the earth fault input supplies the P116 (connection to terminals A7 and A8) or does not supply the P116 (connection to terminals A9 and A10) (refer to Installation chapter: P116/EN IN)

■ If the sum of the currents that power the P116 is below 0.65 In (example: 2 phase (A-B) fault – the sum equal to:

0.65 In = IA: 0.325 In - IB: - 0.325 In + IC: 0 In + IN: 0 In), the LED indications, Electromagnetic Flag indicators (Front Panel): 2 - 5, the display and the RS485 comms. are switched off and RL2, RL3, RL4, RL5 and RL6, WD are not energized. Depending on the setting, the earth current is included or not in the above sum (refer to Settings chapter: P116/EN ST).

Phase and Earth Current Transformers Consumption - P116 current input resistance in tripping condition

	I	Rp for a single current input (Ohms) approx.	
		In (Ien) = 1 A	In (Ien) = 5 A
		0.2	31.06
0.5	7.63	0.225	
1	2.89	0.074	
2	0.791	0.035	
3	0.475	0.024	
4	0.328	0.019	
5	0.317	0.019	
10	0.250	0.016	
20	0.235	0.016	
30	0.241	0.016	

■ The P116's current input resistance depends on the value of the current. The table shows the resistance for a single current input of the P116: In = 1 A / 5 A.

■ If earth input supply P116, for phase -earth fault analysis it is necessary to take into account a double value of the resistance, as shown in Table

Binary Inputs (Model A)

Setting in menu	Filtering time	Binary Inputs					
		Nominal Voltage range	Voltage operating range	Min. polarisation voltage	Max. polarisation current	Maximum holding current after 2 ms	Maximum continuous withstand
dc	5 ms	24 – 250 Vdc	19.5 – 300 Vdc	19.5 Vdc	35 mA	2.3 mA	300 Vdc
ac	■ 7.5 ms (at 50 Hz) ■ 6.25 ms (at 60 Hz)	24 – 240 Vac	19.5 – 264 Vac	19.5 Vac	35 mA	20 mA	264 Vac
ENA (ac/dc)	■ 15 ms (at 50 Hz) ■ 12.5 ms (at 60 Hz)	24 – 250 Vdc 48 – 240 Vac	■ 19.5 – 300 Vdc ■ 39.4 – 264 Vac	■ 19.5 Vdc ■ 39.4 Vac	35 mA	■ dc : 2.3 mA ■ ac : 20 mA	■ 300 Vdc ■ 264 Vac
220 Vdc	5 ms	220 Vdc	154 – 264 Vdc	154 Vdc		3.5 mA (at 220 Vdc)	264 Vdc
129 Vdc	5 ms	129 Vdc	105 – 145 Vdc	105 Vdc		3.5 mA (at 129 Vdc)	264 Vdc
110 Vdc	5 ms	110 Vdc	77 – 132 Vdc	77 Vdc		3.5 mA (at 110 Vdc)	264 Vdc

(cont.)

Binary input energy consumption (holding current)

Logic input burden for dc, ac, ENA	<ul style="list-style-type: none"> ■ < 18 mA per input (at 24 Vac) RMS value ■ < 15 mA per input (at 48 Vac) RMS value ■ < 10 mA per input (at 110 Vac) RMS value ■ < 8 mA per input (at 127 Vac) RMS value ■ < 2.5 mA per input (at 230 Vac) RMS value ■ < 2.3 mA per input (at 24-240 Vdc)
Logic input burden for 220Vdc, 129Vdc, 110Vdc	■ < 3.5 mA per input (at nominal voltage)
Logic input recognition time	As filtering time + 5 ms ± 5 ms

Impulse Output for the Trip Coil

Trip energy

Required nominal parameters of sensitive CB coils, MiTOP or strikers connected to Energy output

From nominal voltage 12 to 24 Vdc	$E \leq 0.1 \text{ J}$
--------------------------------------	------------------------

The trip energy for the trip coil is stored by a capacitor built into the protection relay. The capacitors are charged by a current input or the auxiliary voltage. The duration of the trip pulse is 50 ms (if output is not burden). The pause between the individual pulses depends on the impedance of the trip coil and on the current level. The pulse lasts as long as the activation threshold is exceeded. During the trip pulse, the capacitor is unplugged from the charging source so the voltage level of the energy output depends on the discharging time.

Impulse Output for Flag Indicator or Auxiliary Relay (Model A)

Trip energy

Required nominal parameters of the standalone flag indicator connected to Energy output	$E \leq 0.01 \text{ J}, 24 \text{ Vdc}$
---	---

The trip energy for the flag indicator is stored by a capacitor built into the protection relay. The capacitors are charged by a current input or the auxiliary voltage. The duration of the trip pulse is 50 ms (if output is not burden). The pause between the individual pulses depends on the impedance of the flag indicator and on the current level. The pulse lasts as long as the activation threshold is exceeded

Output Relay Characteristics

Contact ratings

Contact relay	Dry contact, Ag Ni
Carry capability	5 A continuous
Rated Voltage	250 Vac

Breaking characteristics for RL1, RL2 (Model A), RL1, WD (Model L)

AC breaking capacity	<ul style="list-style-type: none"> ■ 1250 VA resistive (cos φ = unity) ■ 1250 VA inductive (cos φ = 0.7)
Short-duration capacity	25 A for 3 s
Making capacity	150 A for 30 ms
AC breaking capacity	<ul style="list-style-type: none"> ■ 1250 VA resistive (cos φ = unity) ■ 1250 VA inductive (cos φ = 0.7)
DC breaking capacity	250 Vdc; <ul style="list-style-type: none"> ■ 50 W resistive ■ 35 W inductive (L/R = 40 ms)
Operation time	<10 ms

Durability

Loaded contact	10 000 operations minimum
Unloaded contact	100 000 operations minimum

Breaking characteristics for RL3, RL4 (Model A)

AC breaking capacity	1000 VA resistive (cos φ = unity) 1000 VA inductive (cos φ = 0.7)
Short-duration capacity	10 A for 3 s
Making capacity	50 A for 30 ms
DC breaking capacity	250 Vdc; <ul style="list-style-type: none"> ■ 30 W resistive ■ 15 W inductive (L/R = 40 ms)
Operation time	< 10 ms

Durability

Loaded contact	10 000 operations minimum
Unloaded contact	100 000 operations minimum

Breaking characteristics for RL5, RL6, RL0 (WD) (Model A)

AC breaking capacity	<ul style="list-style-type: none"> ■ 1250 VA resistive (cos φ = unity) ■ 1250 VA inductive (cos φ = 0.7)
Short-duration capacity	20 A for 3 s
Making capacity	100 A for 30 ms
DC breaking capacity	250 Vdc; <ul style="list-style-type: none"> ■ 50 W resistive ■ 25 W inductive (L/R = 40 ms)
Operation time	<10 ms

Durability

Loaded contact	10000 operations minimum
Unloaded contact	100000 operations minimum



MiCOM P116

Protection functions

Functional Overview

(Description of ANSI code nos. see Functions Table below)

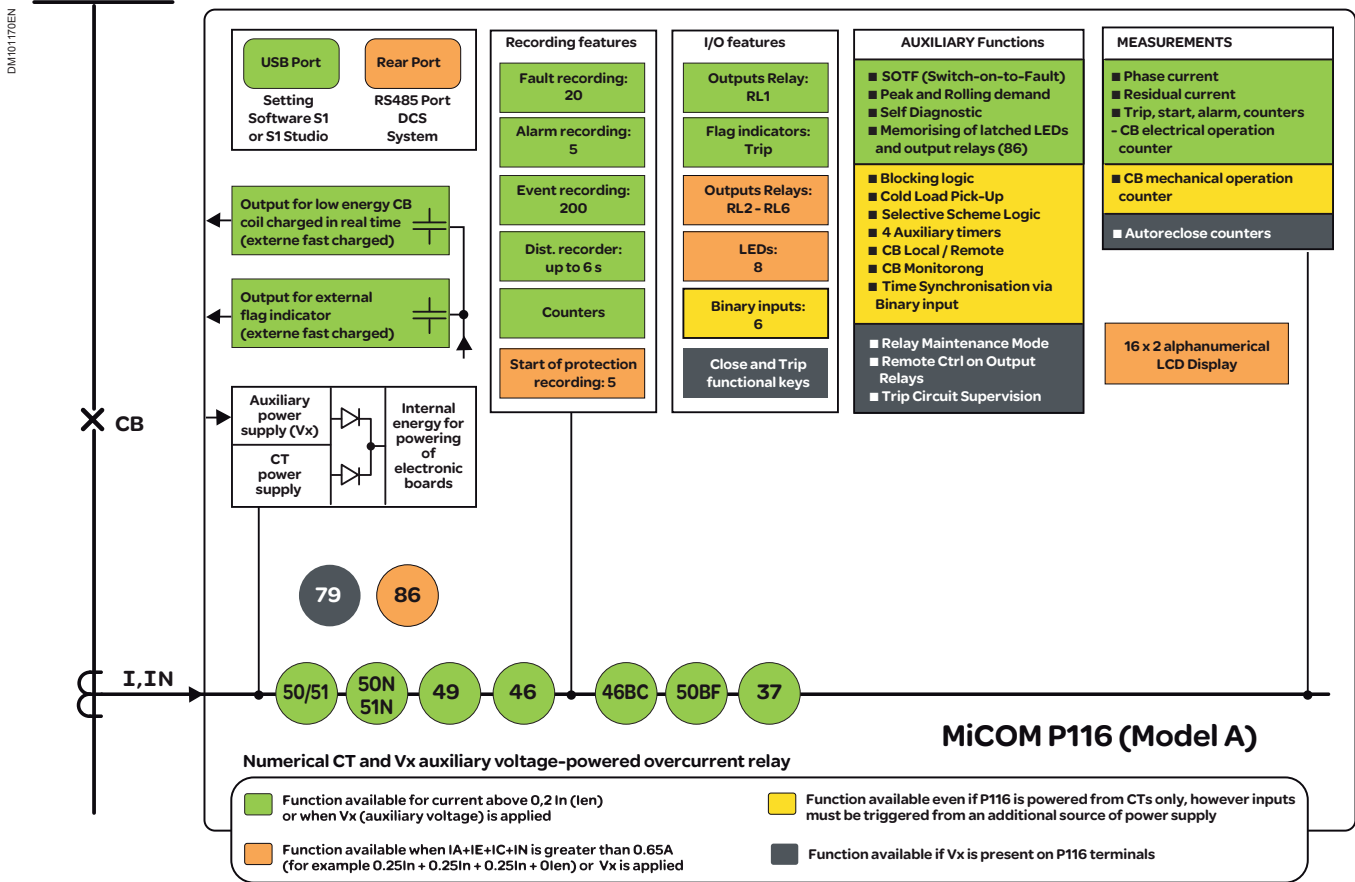

ANSI Code	Functions	Model A	Model L
37	Undercurrent	■	
46	Negative phase sequence overcurrent	■	
46BC	Broken conductor detection (I2/I1)	■	
49	Thermal overload (true RMS): 2 independent thresholds (Alarm, Trip)	■	■
50BF	Circuit breaker failure	■	■
50/51	Three-phase non directional overcurrent: 3 independent thresholds (12 groups of IDMT curves)	■	■
50N/51N	Phase-earth non directional overcurrent: 3 independent thresholds (12 groups of IDMT curves)	■	■
50/51	Switch on to fault (SOTF)	■	
79	Autorecloser option (4 shots) (Note 2)	■	
86	Output relay latching (Note 1)	■	

(Note 1): Function available even if the P116 is not supplied from the Vx auxiliary power but currents must be higher than the CT powering threshold:

$$I_n = |\bar{I}_A + \bar{I}_B| + |\bar{I}_C + \bar{I}_N| > 0.65 I_n$$

(Note 2): Function available if P116 is supplied from the Vx auxiliary power supply

Functions	Model A	Model L
Inrush blocking	■	■
Blocking logic (Note 1)	■	
Selective relay scheme logic (Note 1)	■	
Cold load pick-up (Note 1)	■	
2 setting groups (Note 1)	■	
Output for MiTOP, low energy sensitive (12-24VDC/0.1J) CB coil or striker	■	■
Output for standalone flag indicator (24VDC/0.01J)	■	
1 "Trip" (standard option) + 4 (ordering option, configurable) electro-magnetic indicator flags (Model A)	■	■
Freely configurable binary inputs / outputs contacts (watchdog contact WD included)	6/7	0/2
8 signalling LEDs ("Healthy" + "Trip" + "Alarm" + 5 freely configurable LEDs) (Note 2)	■	■
Circuit breaker supervision and counters (Note 1)	■	
Trip circuit supervision	■	
Fault records for 20 most recent trips / Alarm records for the 5 most recent alarms	■ / ■	■ / -
Event records (up to 200 events)	■	
Disturbance records (up to 6 s)	■	■
Front USB port for local downloading of settings, events and/or fault records with self-supplying facilities	■	■
Rear port RS485 communications (Modbus RTU and IEC60870-5-103) (Note 2)	■	
Time synchronization: via rear communications port (DCS) and/or via digital input (external clock) (Note 1)	■	
Measurements (Note 2)	■	■
Maximum and mean current values	■	
Setting software: MiCOM S1 and/or S1 Studio	■	■
Optional cassette (adaptor) for: wall-mounted or flush-mounted solution with withdrawable feature	■	■

(Note 1): Function available even if the P116 is supplied from CTs only (without Vx /loss of Vx), but in this case inputs must be triggered from an additional power supply source

(Note 2): Function available even if the P116 is not supplied from the Vx auxiliary power but currents must be higher than the CT powering threshold:
 $I_n = |I_A + I_B| + |I_C + I_N| > 0.65 I_n$

Undercurrent Protection (37)

MiCOM P116 relays provide definite time undercurrent protection. This function allows typical applications such as loss of load or simple broken conductor detection. The undercurrent stage can be blocked when the circuit breaker is opened.

Negative Sequence Overcurrent (46)

The MiCOM P116 relays include a programmable function specially designed to detect unbalanced load or fault conditions.

The negative sequence overcurrent (I2>) stage has the same setting ranges as the phase overcurrent function.

Thus, a negative sequence overcurrent element can operate for both phase-to-phase and phase-to-earth faults.

The I2> stage can be independently selected as a definite time DMT) or inverse time-delay (IDMT) with different types of curves (IEC, IEEE/ANSI, RI, RECT).

Broken Conductor (46BC)

A typical unbalanced fault that can occur on the system is an open circuit fault. This fault can arise from a broken conductor, a discrepancy in the position of the poles of one switchgear or a blown fuse.

MiCOM P116 relays can measure the ratio of negative to positive sequence current (I2/I1).

This fully programmable function offers more sensitivity and stability than pure negative sequence measurement.

Thermal Overload (49)

The protection of transformers and cables must take into account their particular thermal characteristics.

MiCOM P116 relays include a thermal replica element based on the true RMS value of the current, up to the 10th harmonic. Alarm and Trip overload thresholds and time constant are fully programmable to match each application requirement.

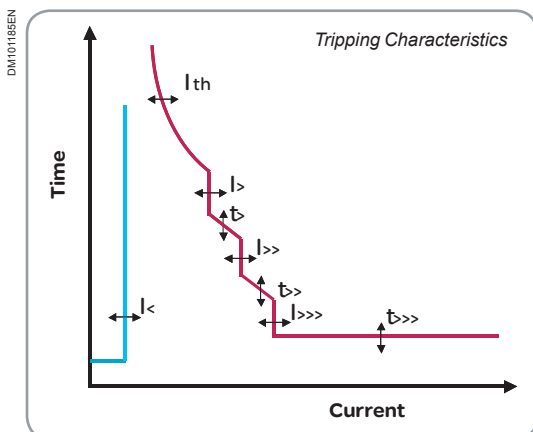

MiCOM P116

Protection functions

(cont.)

Circuit Breaker Failure (50BF)

The circuit breaker failure protection function verifies the effective opening of the CB using a dedicated undercurrent threshold.

The circuit breaker failure function can be activated by the trip of an internal protection function and/or an external command through the relevant digital input. The circuit breaker failure protection function can also be used to trip upstream circuit breakers.

Three-Phase Overcurrent (50/51) and Earth Fault Overcurrent (50N/51N)

Three independent stages are available both for phase and earth fault protection. For the first and second (50/51 only) stages the user may independently select a definite time delay (DMT) or an inverse time delay (IDMT) with different types of curves (IEC, IEEE/ANSI, RI, RECT).

Each stage and related time-delay can be programmed to provide maximum selectivity.

The IDMT stages have a selectable reset feature: DMT (0 to 600 s) or an IDMT timer so as to reduce clearance times when intermittent faults occur.

The MiCOM P116 relays have separate instantaneous and delayed indications for each stage and output relays and LEDs can be configured to indicate the faulted phase(s).

Each protection stage can be disabled, configured to trip a circuit-breaker or to issue an ALARM signal only.

Switch-on-to-Fault (based on 50/51)

The closing of a circuit breaker might inadvertently lead to a short-circuit fault due to a maintenance ground clamp not yet removed. The P116 relays incorporate a settable switch-on-to-fault protection function. It provides an instantaneous trip over a settable time period after local or remote manual closure.

Inrush current in transformer applications can have an influence on the selectivity of instantaneous trips; the short time-delay (DMT) can therefore be set for this protection element in order to maintain selectivity and make it possible to have a current threshold below any inrush current peak.

One independent DMT current stage is available for phase fault protection.

Autorecloser (79)

MiCOM P116 dual-powered relays incorporate a 4-shot autorecloser. All programmed protection functions may independently start any of the shots and the user can program which functions are allowed to trip after any of the shots.

To prevent an excessive number of reclosing cycles in a short period of time, a setting can be used to define the maximum number of reclosing cycles allowed in a period of time after the first one was detected.

Dead and reclaim times are freely adjustable.

Front panel LEDs can be configured to display the status of the autorecloser.

A counter stores the number of reclose commands. This information can be displayed either locally or remotely.

The autorecloser can be enabled when the auxiliary power supply is present.

Inrush Blocking

The 2nd Harmonic Blocking detects high inrush current inflows that occur upon connection of transformers or rotating machines. The function will block the phase overcurrent, earth fault and negative sequence overcurrent elements (freely selectable).

Timers AUX1, AUX2, AUX3, AUX4

Timers operate if the state of an input mapped to this function changes in such a way that the function will be triggered. Timers can be used for CB tripping or alarm signalling.

This function is available when inputs are energised via an auxiliary power supply.

MiCOM P116

Protection functions

(cont.)

2

Blocking Logic

When MiCOM P116 relays are used in critical networks, the management of protection relays must take surrounding devices into consideration. Any blocking digital inputs can be independently configured to lock any combination of selected elements (i.e. current stages, thermal replica, etc).

A typical application is to use a dedicated digital input to block the time-delayed settings of phase/earth fault protection in a relay in response to the phase/earth fault start condition of a downstream relay.

This function allows the MiCOM relays to clear the fault quickly and correctly when used in a cascading scheme.

Selective Relay Scheme Logic

The P116 relays include selective relaying scheme logic.

A dedicated digital input can temporarily alter the time-delay settings in response to the phase/earth fault start condition of a downstream relay.

This function allows the MiCOM relays to quickly clear the fault when used in a cascading scheme.

Cold Load Pick-Up

Cold load pick-up temporarily raises the setting of selectable stages closer to the load profile in order to avoid unwanted trips.

The setting value can be increased by 800% for example for a settable duration. To trigger this function, the CB closed position or current criteria is used.

Output Relay Latching (86)

The RL2-RL6 output contacts may be latched freely.

Latching status information is stored so that even if the P116 does not have enough power to trigger the output contacts (CT powering threshold: $I_n = |I_A + I_B| + |I_C + I_N| < 0.65 I_n$), after the return of sufficient power the latched statuses of the LEDs and outputs are recovered.

Latched outputs can be reset via the activation of a logic input through the front panel interface or by remote communication.

Instantaneous Information

Outputs and LEDs can be programmed with instantaneous information from freely selectable protection elements: with or without latching.

Additionally, every start of a protection element is recorded in the event recorder and the instantaneous recorder.

The instantaneous information is typically generated within 30 ms after the threshold has been exceeded with a load current and/or auxiliary voltage applied.

In a switch-on-to-fault case without auxiliary voltage powering, this instantaneous information is typically generated within 70 ms.

Trip Via Binary Input

Opto-isolated binary inputs are freely configured to timers AUX1 and/or AUX2.

This function works if inputs are triggered via the auxiliary voltage and when sufficient power is applied to the relay.

Communication & Synchronization

The MiCOM P116 offers a wide range of communication protocols allowing its utilization in most network control and data acquisition systems (via Modbus, IEC 60870-5-103). The protocol can be selected in the P116 menu.

It has been designed for permanent multi-drop connection through the rear RS485 communication port.

The MiCOM P116 incorporates an internal clock to allow 1 ms accuracy time tagging of alarms, events, fault and disturbance records. To avoid any drifting of the time-tagging clock, it's necessary to periodically synchronize the relays. To do this the P116 offers two solutions:

- Synchronization from the substation control system via the rear communication port.
- Synchronization from an external clock via a dedicated digital input.

The back-up capacitor of the internal clock is charged from an auxiliary voltage supply only and supports the internal clock typically up to three days.

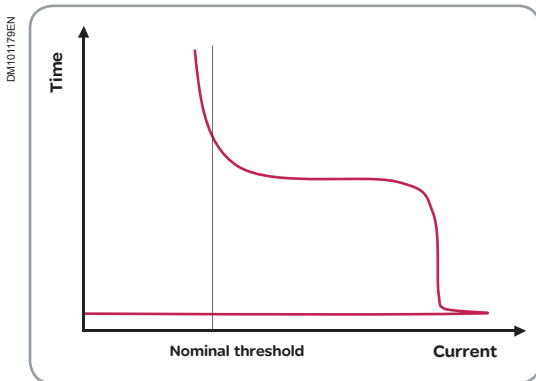

MiCOM P116

Control & Monitoring

2

Two Setting Groups

External conditions may require the need for different settings or I/O configuration. The MiCOM P116 provides two independent setting groups. The active setting group can be switched from the local HMI or due to external conditions (digital input change of state or DCS control).

The two setting groups include protection settings, binary inputs, outputs and LEDs configuration.

Switching between setting groups is possible even while a protection function is active (no time delay is lost). This allows this function to be used in advanced applications where the specific parameters (including I/O) have to be changed during certain processes.

Local/Remote Mode of CB Commands

The goal of this feature is to make it possible to block commands sent remotely through communication networks (such as setting parameters, control commands, etc.) in order to prevent any accidents or maloperation during maintenance work performed on site.

The local mode can be set via the HMI, a digital input assigned to this feature or an RS485. The Local/Remote mode state can be indicated via the HMI.

Circuit Breaker Command

Circuit breaker control is available from the front panel user interface, optically-isolated inputs and remotely via substation communications. Circuit breaker control is also possible via the function keys (Close/Open).

It is possible to send a local open/close command through the HMI upon operator confirmation.

Trip Supervision

Trip circuit supervision in both circuit breaker open and closed states is possible using the optically isolated-inputs included in the P116 scheme logic.

Circuit Breaker Condition Monitoring

The circuit breaker condition monitoring features include:

- Monitoring the number of breaker trip operations
- Recording the sum of the broken current quantity ΣI^x , (where x: 1 or 2)
- Monitoring the breaker operating time

An alarm signal is emitted if the above parameters exceed the settable threshold.

Event Recording

200 events are stored in the MiCOM P116 relays (even after a power supply loss). Events include input/output state changes, alarms and contact operations.

To upload them, it is possible to use the front USB port (MiCOM S1) or the rear serial port (DCS). Event records are stored in a non volatile FRAM memory. All events are time-stamped to 1 ms.

Fault, Alarm & Instantaneous Recording

The last 20 faults, 5 alarms and 5 instantaneous records are stored inside the MiCOM P116 relays.

Each fault includes:

- Record number
- Fault time
- Active setting group
- Faulted phase
- Protection operation
- Magnitude of input quantities.

Fault indication helps the user to clearly identify the fault and monitor the relay's settings and operations as all information is available on the relay HMI.

Fault records are stored in a non-volatile FRAM memory.

(cont.)

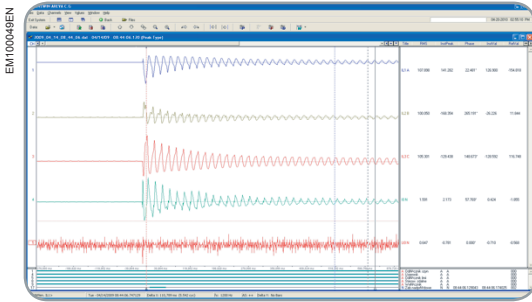

WaveWin – Data Analyzer Software

Disturbance Recording

Up to 5 disturbance files are stored in the relay. Even if the total duration is set to 6 s, it is fully adjustable for easy adaptation to customer requirements. They are stored in COMTRADE format.

The disturbance recording function is triggered either by any of the programmed thresholds, by an external input, or through the communications. All digital and analog information is stored in non-volatile FRAM memory and can be transferred using the front communication port or the rear port to be used by an external data analyser. Disturbance records are stored in a non-volatile FRAM memory.

I/O Configuration

Every input and output can be freely configured to available functions (blocking of protection element, reset LED or outputs, start, trip of every protection element, etc). Any input and output can be assigned to any predefined function.

The P116 can be fitted with (ordering option):

- Universal binary inputs which have selectable options: AC only, DC only or AC/DC energizing criteria with enhanced immunity to transients and disturbances, which can appear in secondary wiring.
- DC inputs with a selectable operation threshold (110V DC / 127V DC / 220V DC).

Relay Maintenance Mode

The P116 incorporates direct control of the output relays (without the need to inject any current). This functionality allows the user to quickly check the external wiring of the relay's output contacts.

Support Software

MiCOM S1 Studio and MiCOM S1 (Windows™ compatible) support software is available for the entire MiCOM family, including the P116 relays.

This Support Software is used to set all parameters in the P116 or download setting parameters, fault and event records. Communication with a PC is managed by the front USB port of the P116.

Self-Monitoring

Comprehensive self-monitoring procedures within the P116 ensure that internal hardware or software errors are detected and do not cause malfunctions of the device. When the auxiliary voltage is turned on, a functional test is carried out. Cyclic self-monitoring tests are run during operation. Any deviations are stored in non-volatile memory and determines whether protection is blocked or an alarm is raised. The result of the fault diagnostics determines whether the protection unit will be blocked or only an alarm will emitted.

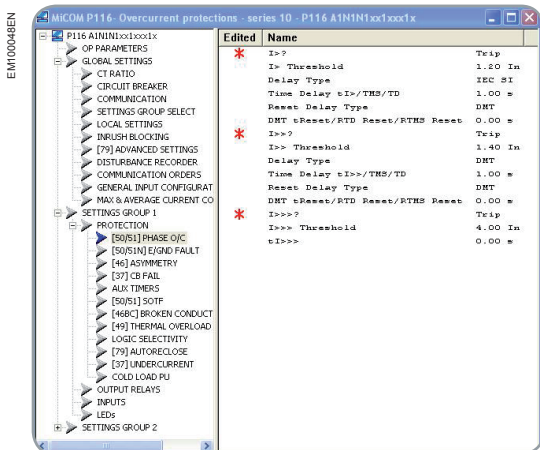

MiCOM S1 Studio- Communication software



MiCOM P116

Setting ranges

Protection functions settings

Function	Setting range		Step
	min.	max.	
[37] Under Current G1/G2 (Model A)			
I< ?	Disabled, Trip, Alarm, Trip with Inrush blocking, Trip with Latching, Trip with Inhibition on 52A, Alarm with Inhibition on 52A		
I<	0.1 In	2 In	0.01 In
tI<	0.05 s	200 s	0.01 s
[46] Negative sequence overcurrent G1/G2 (Model A)			
I2> ?	Disabled, Trip, Alarm, Trip with Inrush blocking, Trip with Latching		
I2>	0.1 In	4 In	0.01 In
Delay Type	DT or IDMT (IEC_S1, IEC_V1, IEC_E1, IEC_LT1, IEC_ST1, C02_P20, C08, IEEE_MI, IEEE_V1, IEEE_E1, RXIDG, BPN EDF, RI, RECT, C02_P40 curve)		
tI2>	0.05 s	200s	0.01s
I2> TMS	0.02	1.5	0.01
I2> Reset Delay Type	DT or IDMT (refer to Operation chapter)		
DT I2> tReset	0.00 s	600 s	0.01 s
[46BC] Broken Conductor G1/G2 (Model A)			
Broken Cond. ?	Disabled, Trip, Alarm, Trip with Inrush blocking, Trip with Latching		
Ratio I2/I1	20%	100%	1%
tBCond	0.05 s	600s	0.01s
Global settings/ O/C advanced			
[46BC] Brkn.Cond I< Block.	0.1 In	1.00 In	0.01 In
[49] Thermal overload G1/G2			
Therm. OL ?	Disabled, Enabled		
Itherm	0.1 In	3.0 In	0.01In
Te (heating)	1 mn	200 mn	1mn
Tr (cooling)	1 mn	999 mn	1mn
Theta Trip	50%	200%	1%
Theta Reset Ratio	20%	99%	1%
Theta Alarm ?	Disabled, Enabled		
Theta Alarm	20%	200%	1%
[50BF] Circuit breaker failure G1/G2			
CB Fail ?	Disabled, Retrip, Alarm		
CB Fail Time tBF	0.1 s	10 s	0.01 s
I< CBF	0.1 In	2 In	0.01 In
High sensitivity current setting			
IN< CBF	Cortec: P116A1N1Nxxxxxxx1x (1 A) or P116A1N4Nxxxxxxx1x (5 A)		
IN< CBF	0.01 len	1.0 len	0.001 len
Medium sensitivity current setting			
IN< CBF	Cortec: P116A1N2Nxxxxxxx1x (1 A) or P116A1N5Nxxxxxxx1x (5 A)		
IN< CBF	0.05 len	2 len	0.01 len
Low sensitivity current setting			
IN< CBF	Cortec: P116A1N3Nxxxxxxx1x (1 A) or P116A1N6Nxxxxxxx1x (5 A)		
IN< CBF	0.1 len	2 len	0.01 len
Block I>?	No, Yes		
Block IN>?	No, Yes		
[50/51] SOTF (switch on to fault) G1/G2			
SOTF ?	Disabled, Trip, Alarm, Trip with Inrush blocking, Trip with Latching		
SOTF	1 In	40 In	0.01 In
tSOTF	0 s	600 s	0.01 s

2

MiCOM P116

Setting ranges

(cont.)

Function	Setting range		Step
	min.	max.	
[50/51] Phase overcurrent G1/G2			
I> ?	Disabled, Trip, Alarm, Trip with Inrush blocking, Trip with Latching		
I>	0.1 I _n	3 I _n (IDMT) 40 I _n (DMT)	0.01 I _n
Delay type	DT or IDMT (IEC_SI, IEC_VI, IEC_EI, IEC_LTI, IEC_STI, C02_P20, C08, IEEE_MI, IEEE_VI, IEEE_EI, RXIDG, BPNEDF, RI, RECT, C02_P40 curve)		
tI>	0.05 s	200 s	0.01 s
I> TMS	0.02	1.50	0.01
I> TD	0.02	100	0.01
I> Reset Delay Type	DT or IDMT (refer to Operation chapter)		
DT I> tReset	0.00 s	600 s	0.01 s
K (RI)	0.1	10	0.1
I>> ?	Disabled, Trip, Alarm, Trip with Inrush blocking, Trip with Latching		
I>>	0.1 I _n	3 I _n (IDMT) 40 I _n (DMT)	0.01 I _n
Delay type	DT or IDMT (IEC_SI, IEC_VI, IEC_EI, IEC_LTI, IEC_STI, C02_P20, C08, IEEE_MI, IEEE_VI, IEEE_EI, RXIDG, BPNEDF, RI, RECT, C02_P40 curve)		
tI>>	0.05 s	200 s	0.01 s
I>> TMS	0.02	1.50	0.01
I>> TD	0.02	100	0.01
I>> Reset Delay Type	DT or IDMT (refer to Operation chapter)		
DT I>> tReset	0.00 s	600 s	0.01 s
K (RI)	0.1	10	0.01
I>>> ?	Disabled, Trip, Alarm, Trip with Inrush blocking, Trip with Latching		
I>>>	1 I _n	40 I _n	0.01 I _n
tI>>>	0 s	200 s	0.01 s
[50/51N] Earth overcurrent G1/G2			
High sensitivity current set			
Cortec code P116A1N1Nxxxxxxx1x (1 A)			
IN_1 (IN>)	0.002 I _n	0.1 I _n (IDMT) 1.0 I _n (DMT)	0.001 I _n
IN_2 (IN>>)	0.025 I _n	1.0 I _n	0.001 I _n
IN_3 (IN>>>)	0.025 I _n	1.0 I _n	0.001 I _n
Medium sensitivity current set			
Cortec code P116A1N2Nxxxxxxx1x (1A) or P116A1N5Nxxxxxxx1x (5A)			
IN_1 (IN>)	0.01 I _n	■ 0.4 I _n (IDMT) ■ 8 I _n (DMT)	0.01 I _n
IN_2 (IN>>)	0.2 I _n	8 I _n	0.01 I _n
IN_3 (IN>>>)	0.2 I _n	8 I _n	0.01 I _n
IN_1 stage ?	Disabled, IN> Trip, IN> Alarm, IN> Trip with Inrush blocking, IN> Trip with Latching		
Delay type	DT or IDMT (IEC_SI, IEC_VI, IEC_EI, IEC_LTI, IEC_STI, C02_P20, C08, IEEE_MI, IEEE_VI, IEEE_EI, RXIDG, BPNEDF, RI, RECT, C02_P40 curve)		
tIN_1	0.05 s	200 s	0.01 s
K (RI)	0.1 s	10 s	0.01 s
IN_1 TMS	0.02 s	1.5 s	0.01 s
IN_1 TD	0.02 s	100 s	0.01 s
IN_1 Reset Delay Type	DT or IDMT (refer to Operation chapter)		
DT IN_1 tReset	0.00 s	600 s	0.01 s
IN_2 stage ?	Disabled, IN>> Trip, IN>> Alarm, IN>> Trip with Inrush blocking, IN>> Trip with Latching		
tIN>>	0 s	200 s	0.01 s
IN_3 stage ?	Disabled, IN>>> Trip, IN>>> Alarm, IN>>> Trip with Inrush blocking, IN>>> Trip with Latching		
tIN_3	0 s	200 s	0.01 s

MiCOM P116

Setting ranges

(cont.)

2

Function	Setting range		Step
	min.	max.	
[79] Autoreclose G1/G2 (Model A)			
Autoreclose ?	Disabled, Enabled		
Dead time			
tD1	0.01 s	600 s	0.01 s
tD2	0.01 s	600 s	0.01 s
tD3	0.1 s	600 s	0.01 s
tD4	0.1 s	600 s	0.01 s
Reclaim time			
Reclaim Time tR	0.02 s	600 s	0.01 s
Phase overcurrent			
Fast tripping shots	54321 (trip cycle)	Settings	
Fast O/C Trip (l>, l>>, l>>>)	0 0 0 0	<ul style="list-style-type: none"> ■ 0 - delay O/C protection element ■ 1 - with Fast Trip delay 	
Fast O/C Trip Delay setting	0.00 s	9.99 s	10 ms
Earth/Ground			
Fast tripping shots	54321 (trip cycle)	Settings	
Fast E/Gnd Trip (tIN_1, tIN_2, tIN_3)	0 0 0 0	<ul style="list-style-type: none"> ■ 0 – Time delay E/GND protection element ■ 1 – with Fast Trip delay 	
Fast E/Gnd Trip Delay setting	0.00 s	9.99 s	10 ms
Close Shot			
4321 (close cycle)	Settings		
tI>	0 0 0 0	0 or 1	
tI>>	0 0 0 0	0 or 1	
tI>>>	0 0 0 0	0 or 1	
tIN_1 (tIN>)	0 0 0 0	0 or 1	
tIN_2 (tIN>>)	0 0 0 0	0 or 1	
tIN_3 (tIN>>>)	0 0 0 0	0 or 1	
tAux1	0 0 0 0	0 or 1	
tAux2	0 0 0 0	0 or 1	
Inhibit Trip on [79] close shot	4 3 2 1 (close cycle)	Settings	
Inhibit Trip tI> Shot:	0 0 0 0	0 or 1	
Inhibit Trip tI>> Shot:	0 0 0 0	0 or 1	
Inhibit Trip tI>>> Shot:	0 0 0 0	0 or 1	
Inhibit Trip tIN_1 (tIN>) Shot:	0 0 0 0	0 or 1	
Inhibit Trip tIN_2 (tIN>>) Shot:	0 0 0 0	0 or 1	
Inhibit Trip tIN_3 (tIN>>>) Shot:	0 0 0 0	0 or 1	
Inhibit Trip tAux1 Shot:	0 0 0 0	0 or 1	
Inhibit Trip tAux2 Shot:	0 0 0 0	0 or 1	
<ul style="list-style-type: none"> ■ Cycles: 0 = no action on auto-recloser: definitive trip 1 = trip on protection element pick-up, followed by a reclose cycle ■ Inhibit Trip on Shot: 0 = no inhibit function 1 = auto-reclose without protection trip (trip command inhibited for protection element - no trip command from the auto-reclose function). 			
[79] Autoreclose Advanced Settings			
CB Faulty Monitor.?	Yes or No		
Block via Input ?	Yes or Yes + tI/52a or No		
Start Dead t on	Protection Reset or CB trips		
Rolling demand ?	Yes or No		
Maximum cycle No. Rol. Demand	2	100	1
Time period Rol. Demand	1 mn	24 h	1 mn
Inhibit Time on Close tI	0.0 s	600 s	0.01 s
Signaling Reset	No or Close via 79		

(cont.)

Automation control functions settings

Function	Setting range		Step
	min.	max.	
Blocking Inrush			
Blocking inrush	No, Yes, Closing		
2nd Harmonic Ratio	10%	50%	1%
Inrush Reset Time	0 s	200 s	10 ms
Unblock Inrush Time	0 s	200 s	10 ms
Logic Selectivity G1/G2 (Model A)			
Logic selectivity 1 and logic selectivity 2: This function is used to assign a time-delay to the protection elements mapped to the "Log Sel" inputs. The inputs can be mapped to the following protection elements: I>, I>>, IN_2 (IN>>), IN_3 (IN>>>).			
Sel1?	Disabled or Enabled		
t Sel1	0 s	600 s	10 ms
Sel2?	Disabled or Enabled		
t Sel2	0 s	600 s	10 ms
Auxiliary timers G1/G2 (Model A)			
Aux1 ?	Disabled, Trip, Alarm, Trip with Inrush blocking, Trip with Latching, Load Shedding (LS), AR after LS Hi (Hi state – activates), AR after LS Lo (Lo state – activates)		
Time-delay tAux1	0	600 s	10 ms
Aux2 ?	Disabled, Trip, Alarm, Trip with Inrush blocking, Trip with Latching, Load Shedding (LS), AR after LS Hi, AR after LS Lo		
Time-delay tAux2	0	600 s	10 ms
Aux3 ?	Disabled, Trip, Alarm, Trip with Inrush blocking, Trip with Latching, Load Shedding (LS), AR after LS Hi, AR after LS Lo		
Time-delay tAux3	0	600 s	10 ms
Aux4 ?	Disabled, Trip, Alarm, Trip with Inrush blocking, Trip with Latching, Load Shedding (LS), AR after LS Hi, AR after LS Lo		
Time-delay tAux4	0	600 s	10 ms
Cold Load PU G1/G2 (Model A)			
Cold Load PU ?	Disabled or Current+Input or Input		
Cold load PU Level	20%	999%	1%
Cold load PU tCL	0s	6000 s	100 ms
CLPU I>	Yes or No		
CLPU I>>	Yes or No		
CLPU I>>>	Yes or No		
CLPU IN_1 (IN>)	Yes or No		
CLPU IN_2 (IN>>)	Yes or No		
CLPU IN_3 (IN>>>)	Yes or No		
CLPU Brkn Cond	Yes or No		
CLPU Itherm	Yes or No		
CLPU I2>	Yes or No		
CB Control Time			
tOpen Pulse min	0.1 s	10 s	0.01 s
tClose Pulse (Model A)	0.1 s	10 s	0.01 s
Time-delay for Close (Model A)	0.0 s	200 s	0.01 s
tP pulse (Model A)	1 mn	65000 mn	1 mn
CB Faulty External Monitoring (Model A)			
TCB Faulty External Signal	1 s	200 s	1 s
Remote Control Mode (Model A)			
Remote CTRL Mode	<input type="checkbox"/> Remote only <input type="checkbox"/> Remote + Local		
Unblock SOTF Time (Model A)			
52 Unblock SOTF Time	0 s	200 s	0.01 s

MiCOM P116

Setting ranges

(cont.)

Function	Setting range		Step
	min.	max.	
TC Supervision (Model A)			
TC Supervision ?	No or Yes or Yes - 52A		
TC Supervision tSUP	0.1 s	10 s	0.01 s
CB Supervision (Model A)			
CB Time Supervision?	Yes or No		
Max CB Open time	0.01 s	10 s	0.01 s
Max CB Close time	0.01 s	10 s	0.01 s
CB Diagnostic ?	Yes or No		
Max CB Open No.	1	50000	1
Max Sum Amps^n	0 MA	655.34 MA^n	0.1MA^n
AMPS's n=	1	2	1
Communication Orders (Model A)			
Pulse Time tCOM1	0	200s	10ms
Pulse Time tCOM2	0	200s	10ms
COM2 Order Conf.	RS485 or RS485+Button_C or Button_C This configuration allows adding to Comm.Order 2: pressing of the 'C' clear key located on the front panel of P116. Setting option: RS485+Button_C means that if command tCOM2 (Communication Order 2) via RS485 is executed or 'C' Clear key on the front panel is pressed, the output contact assigned to Comm.Order 2 will be energized via set pulse time		

Recording functions settings

Function	Setting range
Event Records (Model L without Real Time Clock)	
Capacity	200 events
Time-tag	1 millisecond
Triggers	<ul style="list-style-type: none"> ■ Any selected protection alarm and threshold ■ Logic input change of state ■ Logic output change of state ■ Self test events
Fault Records (Model L without Real Time Clock)	
Capacity	20 faults
Time-tag	1 millisecond
Triggers	Any selected protection which trip CB
Data	<ul style="list-style-type: none"> ■ Fault date Fault time ■ Protection thresholds ■ Active Setting Group ■ Fault Origin (faulty phase/earth) ■ Fault measurements
Instantaneous Recorder (available if Model A is powered from Vx only)	
Capacity	5 starting information (instantaneous)
Time-tag	1 millisecond
Triggers	Any selected protection which trip CB
Data	Date, hour, origin (any protection)

Function	Setting range
Alarm Recorder (Model A)	
Capacity	5 alarm information
Time-tag	1 millisecond
Triggers	Any selected protection which is selected for signaling only (set to Alarm)
Data	Date, hour, origin (any protection alarm)

Disturbance Records (Model L without Real Time Clock)	
Total record: max 6 s	
Triggers	Any selected protection alarm and threshold, logic input, remotecommand
Data	<ul style="list-style-type: none"> ■ AC input channels ■ Digital input and ■ Output states frequency value

Function	Default value	Setting range		
		Min.	Max.	Step
Pre-fault Time	0.1 s	0.1 s	2 s	0.01 s
Post-fault Time	0.1 s	0.1 s	1 s	0.01 s
Max Record time	3 s	1.50 s	6 s	0.01 s
Disturb rec Trig	on Inst	on Trip or on Inst.		
Trigger	Protection selected for tripping, Logic input assigned to 'StartDistur.R.'			

MiCOM P116

Base unit

PM110535



P116 basic Flush mounting cassette

Presentation

User-Machine Interface (HMI)

All functions, including protection, automation, communication, LEDs, inputs and outputs, can be programmed and modified using the front panel user interface (Human Machine Interface).

Working language

The LCD informs the user about settings, measurements & faults with a pull-down menu structure allowing easy and quick access to any data. The relay display language can be changed in the menu system:

- English/German/French/Spanish/Portuguese/Russian/Turkish

Wiring

Terminal block connections are made via screw terminals.

■ AC Current Input Terminals

Threaded M4 screw-type plug-in terminals, ring type, with wire protection for conductor cross-section

- 0.2 - 6mm² single-core
- 0.2 - 4mm² finely stranded

■ General Input/Output Terminals

For power supply, binary inputs, contact output contacts and COM for rear communications.

Threaded M3 screw-type plug-in terminals (MSTB 2.5/xx-ST-5.08)

- 0.2 - 4mm² single-core
- 0.2 - 2.5mm² finely stranded

Communication

- Communication software: MiCOM S1 Studio

Type Port	Physical Link	Connectors	Data Rate	Comms. mode	Protocol
RS485 signal levels, two wire (Rear communications port)	Screened twisted pair cable, distance to be bridged: multi-endpoint link: max. 100 m	Screws or snap-on	<ul style="list-style-type: none"> ■ 4800 bauds or ■ 9600 bauds or ■ 38400 bauds or ■ 57600bauds or ■ 115200 bauds (default:19.2 kbit/s)	<ul style="list-style-type: none"> ■ Data Bit: 8 ■ Stop bit: 1 or 2 ■ Parity: <ul style="list-style-type: none"> <input type="checkbox"/> 'No parity' or <input type="checkbox"/> 'Odd parity' or <input type="checkbox"/> 'Even parity' ■ Address: 1 to 254 (default: 1) 	<ul style="list-style-type: none"> ■ Modbus RTU, IEC60870-5-103 (selectable in menu) Isolation to SELV level
USB	USB2.0: <ul style="list-style-type: none"> ■ minimum 1P*28AWG/2C*24AWG, ■ max : 2m 	PC: type A male P116: type mini B 5-pin male	115 200 bauds (fixed)	<ul style="list-style-type: none"> ■ Data Bit:8 ■ Stop bit: 1 ■ Parity: None ■ Address: 1 	<ul style="list-style-type: none"> ■ Modbus RTU



2

Case

Flush mounting case

Dimensions

- Height 184 mm
- Width 157 mm
- Depth 110 mm

Weight

- approx. 3.1 kg
- with optional cassette: approx. 4.2 kg

Dimensions & weight

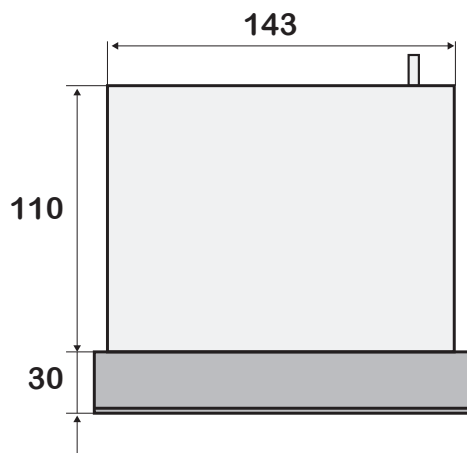
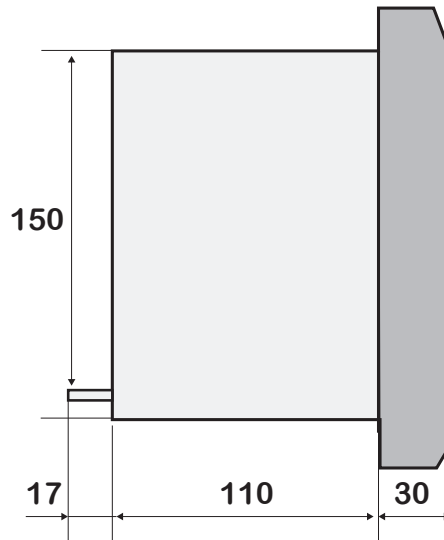
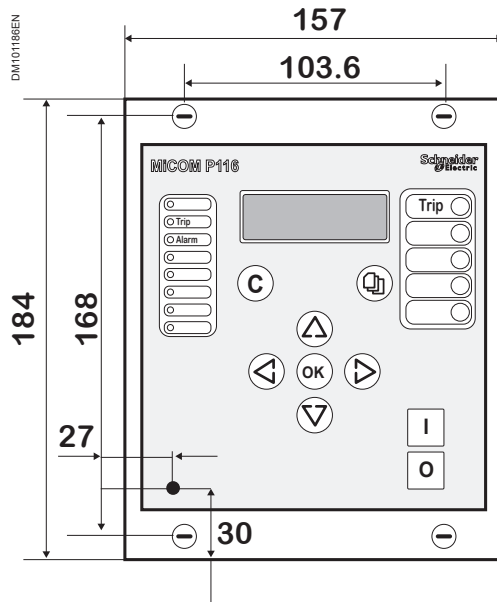

Front panel description

- 1 Green "Healthy" LED: Watchdog
- 2 Red "Trip" LED: Protection trip
- 3 Yellow "Alarm" LED: Alarm signaling
- 4 Up to five red programmable LEDs
- 5 16-character by 2-line alphanumeric liquid crystal display (LCD)
- 6 Clear key
- 7 Read key (jump to RECORDS column)
- 8 4 arrow keys, an enter key
- 9 Electromechanical flag indicators
- 10 CB Close key (Model A)
- 11 CB Open key (Model A)
- 12 USB port for local connection

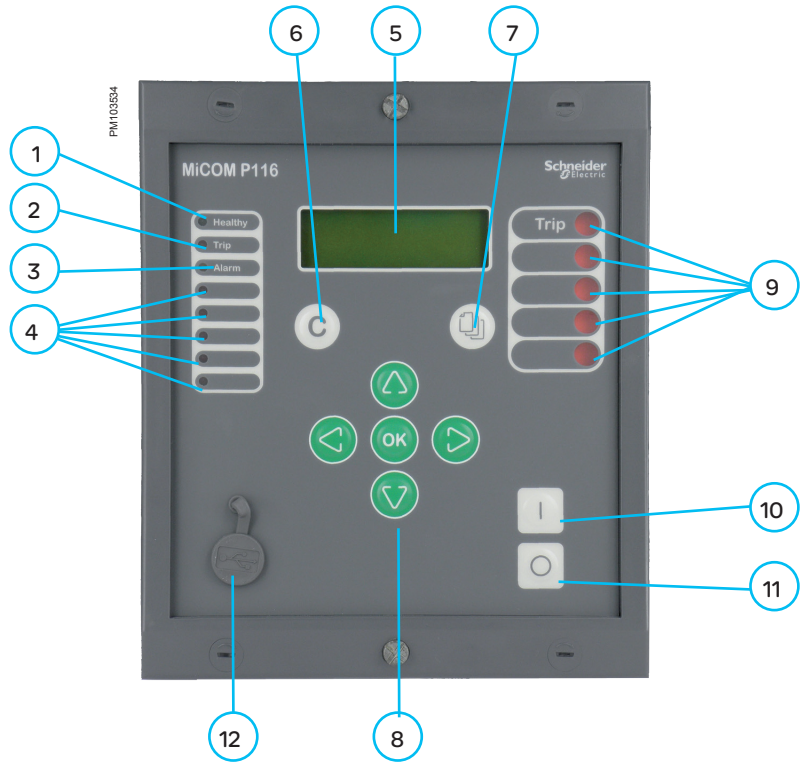

Rear panel description

Basic Flush Mounting Case

- A Current ring terminal block A: Current analogue inputs (phases and earth)
- B Terminal block B: Auxiliary voltage Vaux and contact outputs
- C Terminal block C: Energy outputs (sensitive trip coil, Flag indicator) and RS485
- D Terminal block D: Binary inputs (Model A)
- E Terminal block E: Contact outputs (Model A)
- PE PCT Protective (Earth) Conductor terminal

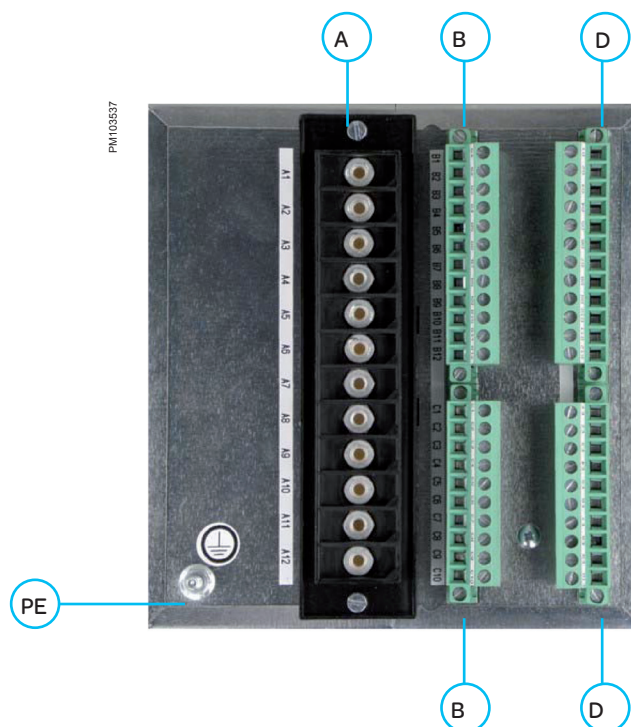

External connection diagrams

2

**MiCOM P116 (Model A):
Typical 3 phase CTs connection.**

Note: The current leads should be connected exactly as shown in the figure.

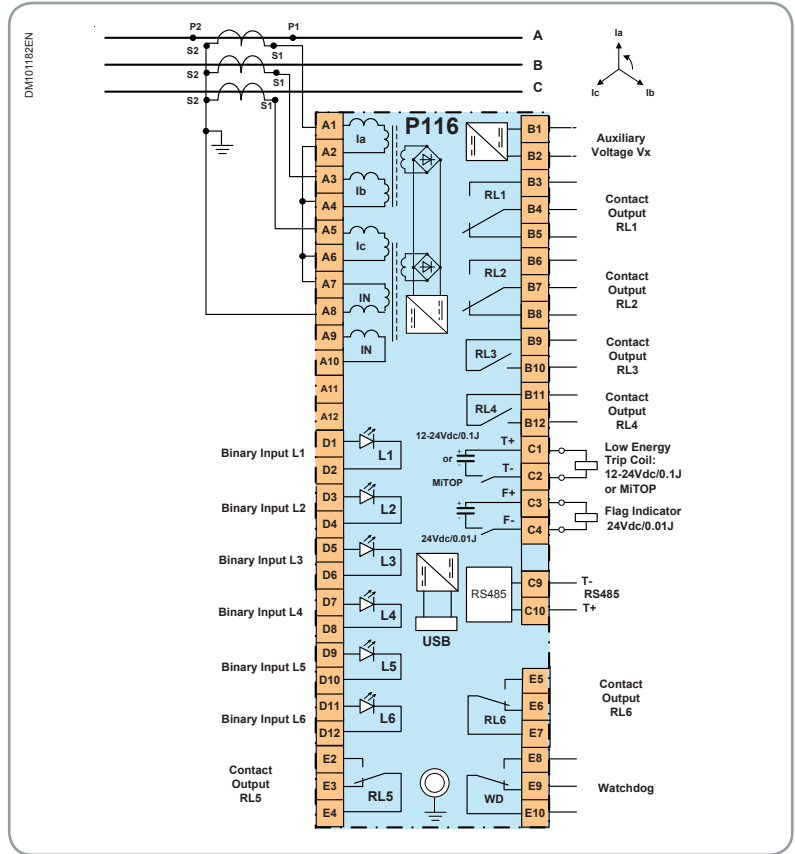

MiCOM P116 (Model A):

Typical 3 phase CTs + Core balanced CT connection.

The P116 is not supplied via a core balance CT. An auxiliary voltage source should be connected to terminals B1-B2 in order to ensure that the P116 is supplied for earth fault currents below 0.2 In.

Note: The current leads should be connected exactly as shown in the figure.

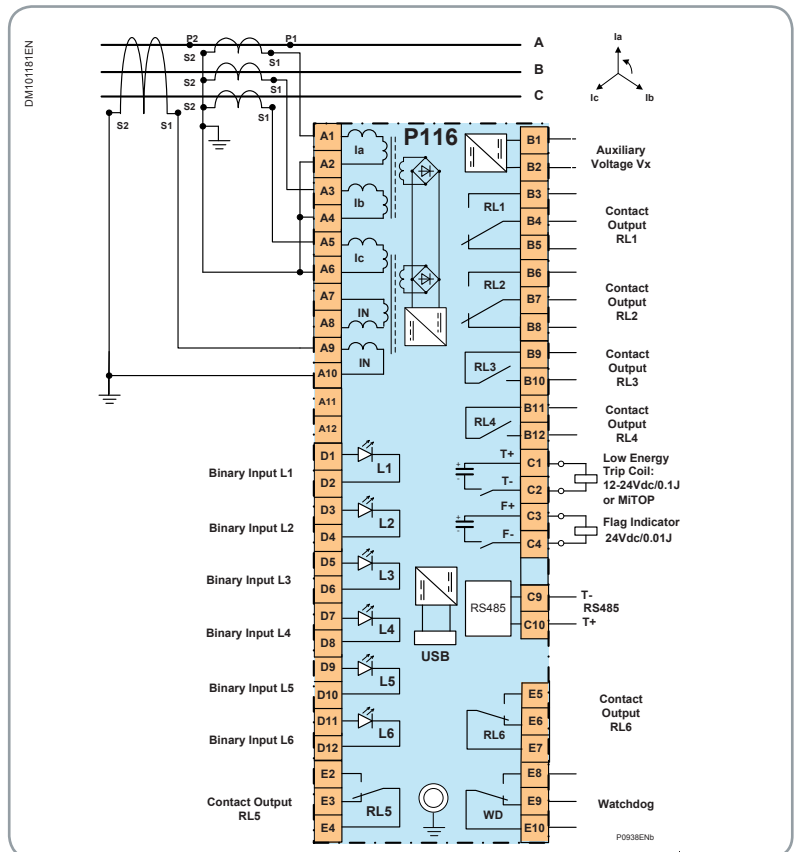

MiCOM P116 (Model A):

Typical 2 phase CTs + Core balanced CT connection.

The P116 is not supplied via a core balance CT. An auxiliary voltage source should be connected to terminals B1-B2 in order to ensure that the P116 is supplied for earth fault currents below 0.2 In.

Note: The current leads should be connected exactly as shown in the figure.

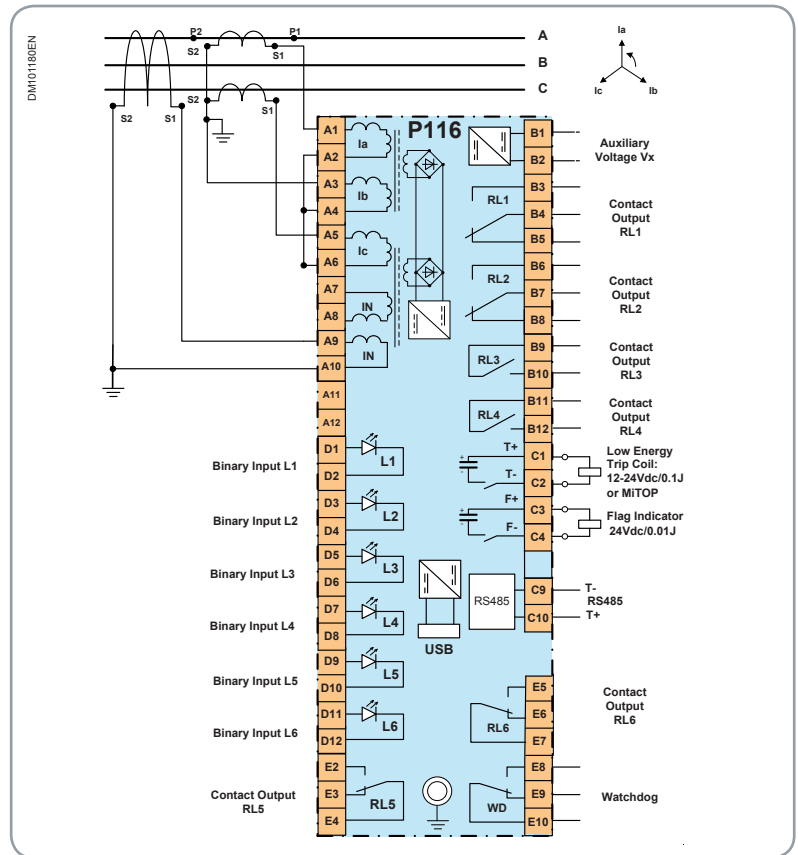

2

Application connection diagrams

MiCOM P116 Model A powered by a WA 25 O:
 Connection example for a P116 Model A powered by a WA 25 O and with a 2-pole connection (A-C)

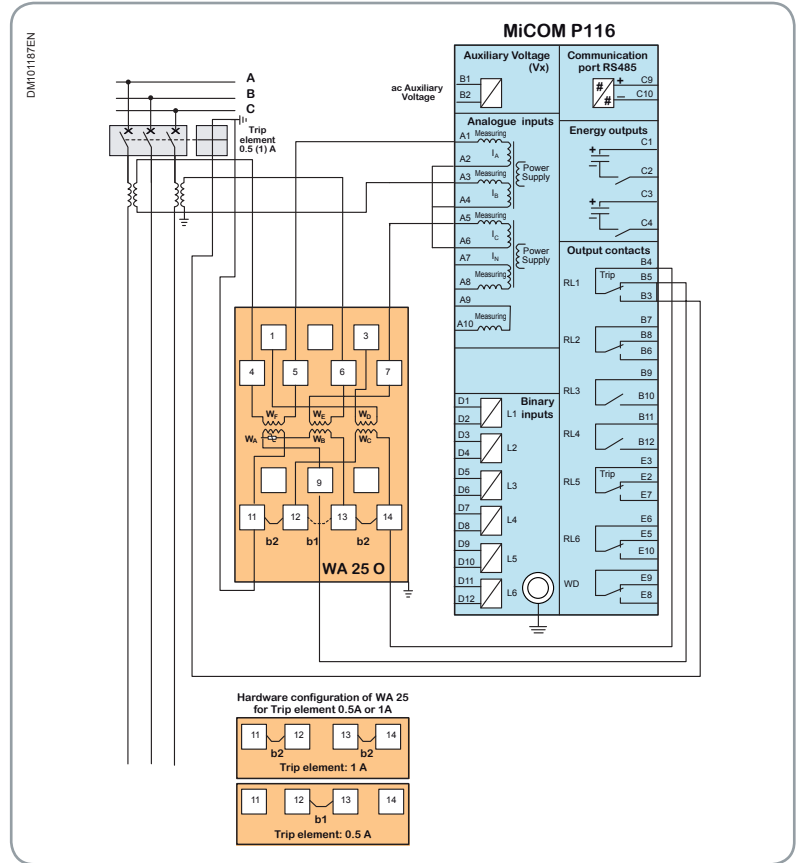

MiCOM P116 Model A powered by a WA 25 O:
 Connection example for a P116 Model A powered by a WA 25 O and with a 3-pole connection (A-B-C)

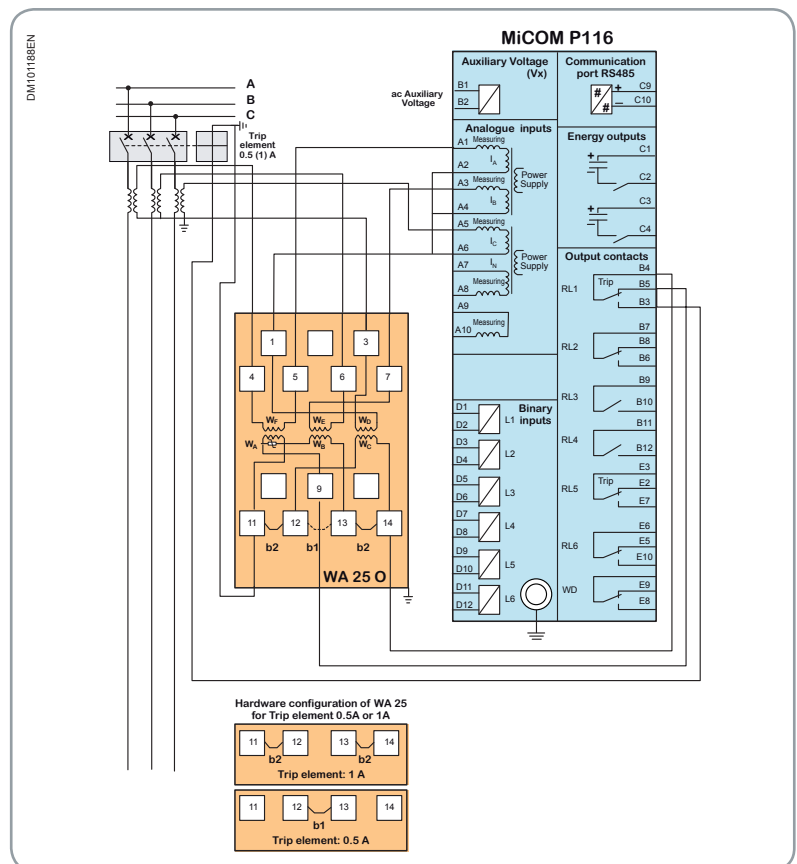

MiCOM P116 Model A powered by a WA 25 O::
 Connection example for a P116 powered by a WA 25 O and with a 4-pole connection (A-B-C-N)

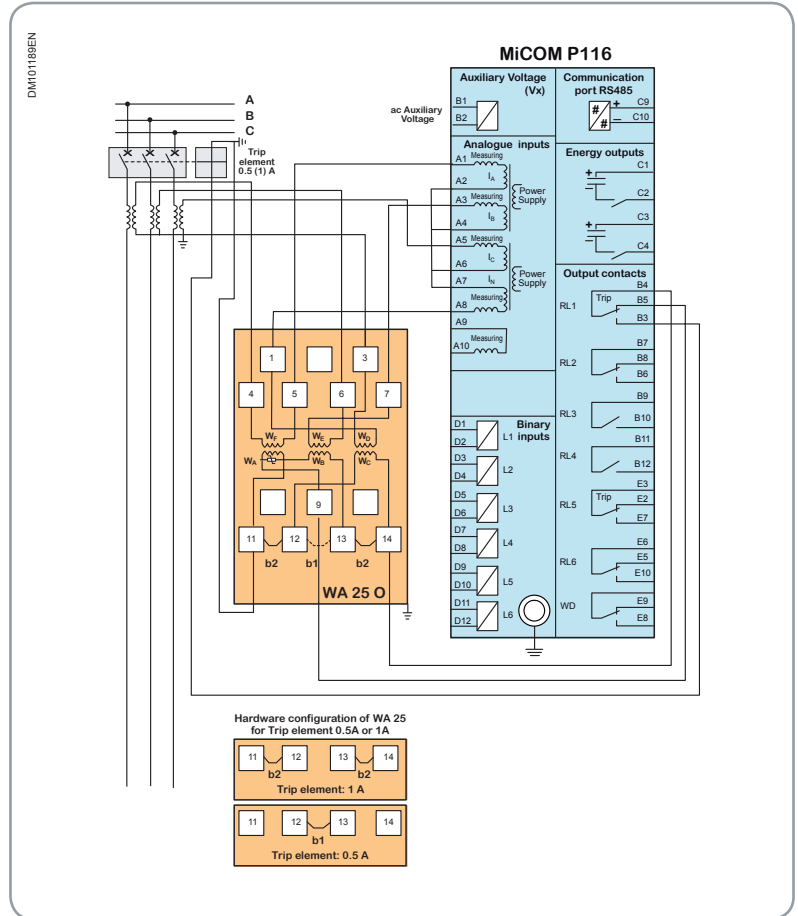

MiCOM P116

Base unit

(cont.)

2

MiCOM P116 Model A powered by an E124::
 Connection example for a P116 powered by an E124 and with a 4-pole connection (A-B-C-N).
 The earth input supplies the relay.

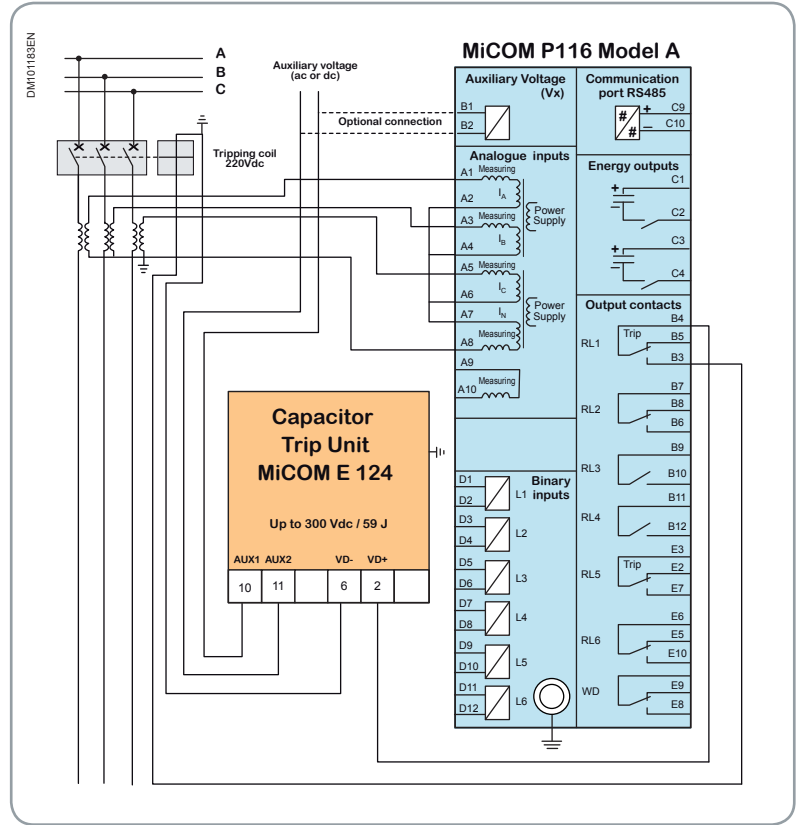

MiCOM P116 powered by an E124:
 Connection example for a P116 powered by an E124 and with a 4-pole connection (A-B-C-N).
 The P116 is not supplied via the earth input.

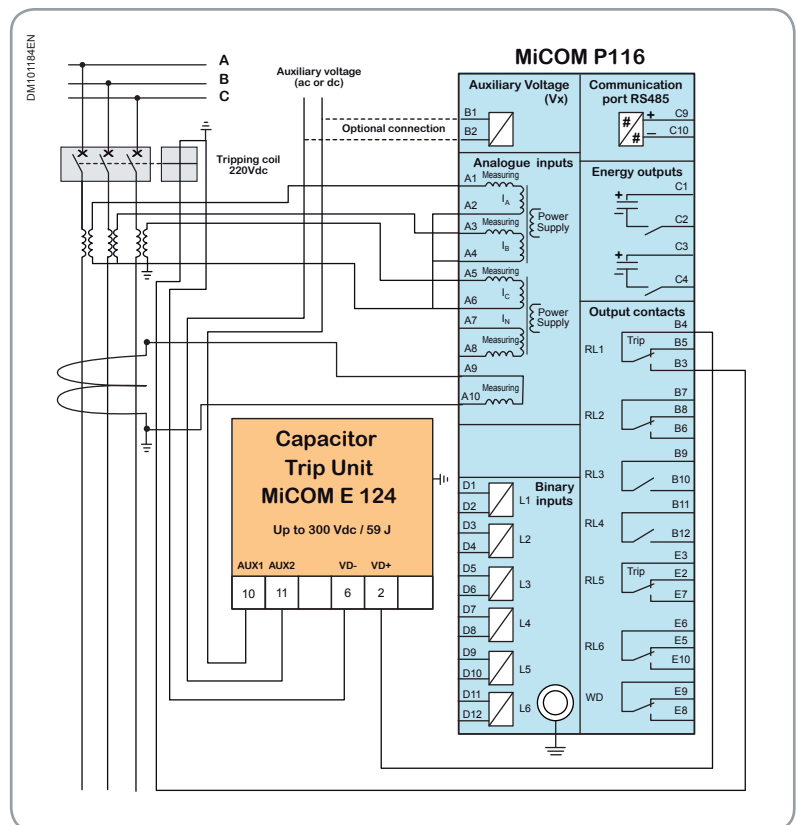

MiCOM P116 (Model L):

Typical 3 phase CTs connection.

Note: The current leads should be connected exactly as shown in the figure.

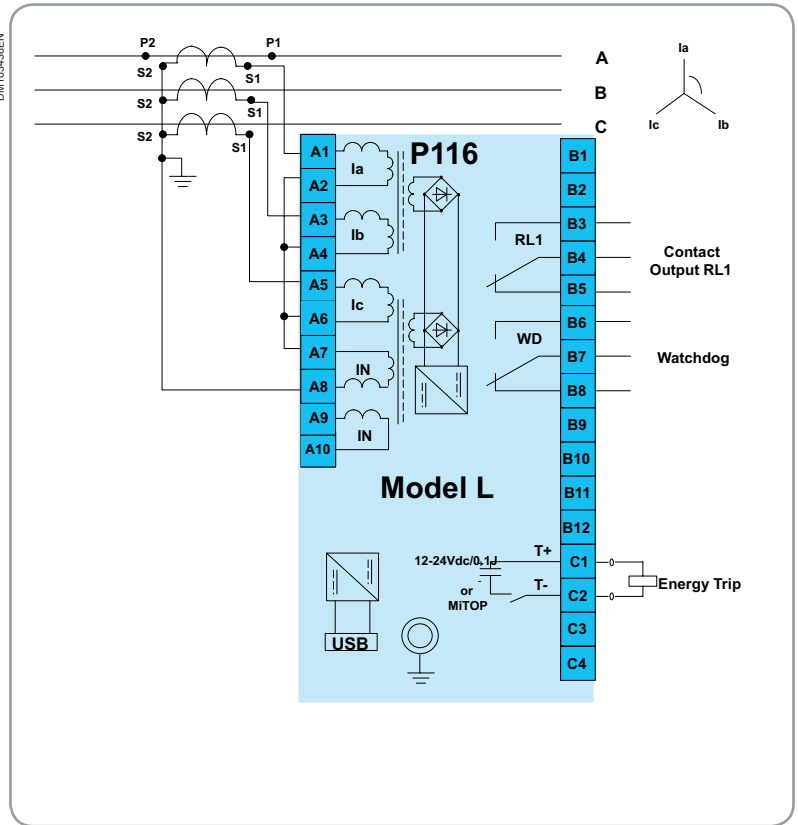

MiCOM P116 (Model L):

Typical 3 phase CTs connection + Core balanced CT connection.

Note: The current leads should be connected exactly as shown in the figure.

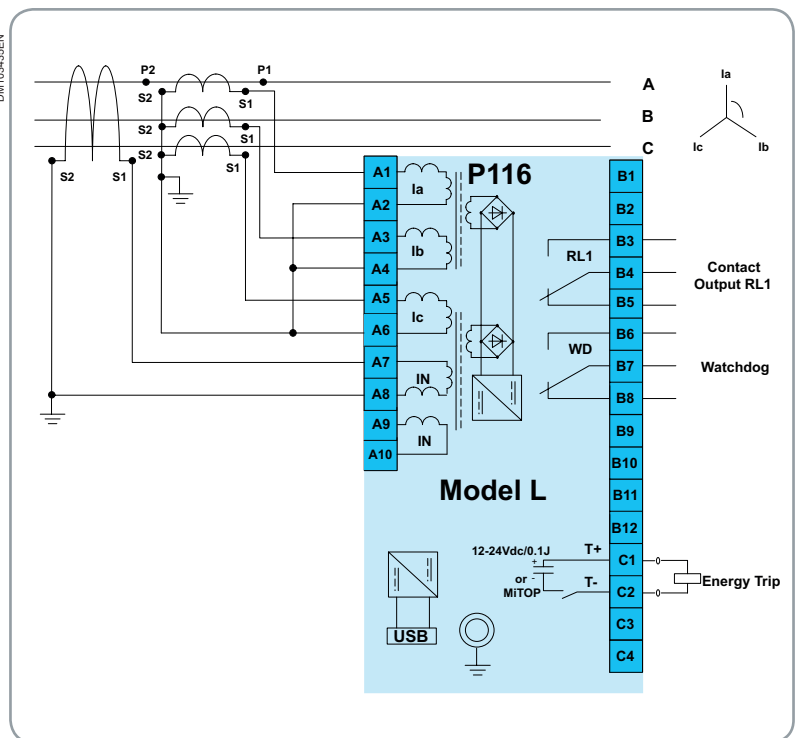

2

MiCOM P116 (Model L):

Typical 2 phase CTs connection + Core balanced CT connection.

Note: The current leads should be connected exactly as shown in the figure.

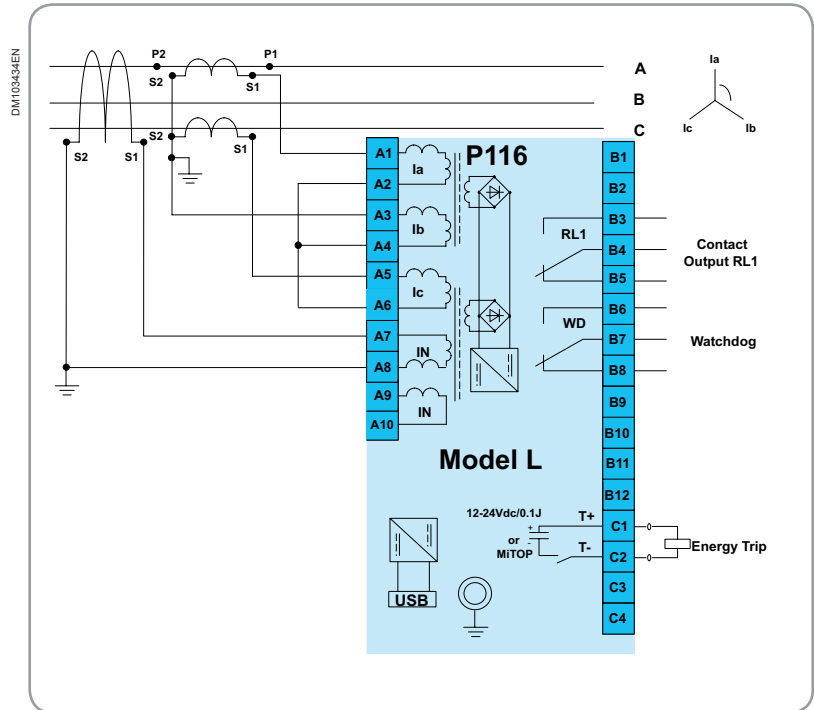

> TOOLS

schneider-electric.com

This international site allows you to access all the Schneider Electric products in just 2 clicks via comprehensive range data-

sheets, with direct links to:

- complete library: technical documents, catalogs, FAQs, brochures...

- selection guides from the e-catalog.

- product discovery sites and their Flash animations.

You will also find illustrated overviews, news to which you can subscribe, the list of country contacts

Automation panorama

This animated tool helps you to select the best Automation Intelligent Electronic Device adapted to your need. This CD includes description of all Schneider Electric IEDs ranges (Sepam, MiCOM, VAMP, Easergy). This selector is also included in the Schneider Electric web site.

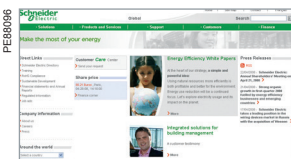
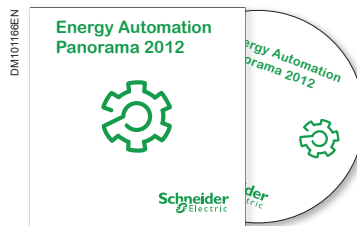

Range description	5
MiCOM series 10	25
MiCOM series 20	99
Selection table	101
Sensor inputs	102
Setting Software	103
Accessories	103
Environmental characteristics	104
MiCOM P122 / P123 / P127	106
Numerical three phase and earth fault overcurrent relay description	106
Ratings	107
Protection functions	109
Control & Monitoring	114
Setting ranges	115
Base unit	127
Presentation	127
Dimensions & weight	128
Description	129
Connection diagrams	130
MiCOM P220 / P225	132
Numerical CT and auxiliary voltage powered overcurrent relay description	132
Ratings	133
Protection functions	135
Control & Monitoring	139
Setting ranges	142
Base unit	146
Presentation	146
Dimensions & weight	147
Description	148
Connection diagrams	149
MiCOM P521	150
Numerical CT and Vx auxiliary voltage-powered overcurrent relay description	150
Ratings	152
Protection functions	153
Control & Monitoring	158
Setting ranges	161
Base unit	165
Presentation	165
Dimensions & weight	166
Description	167
Connection diagrams	168

MiCOM P921 / P922 / P923	170
Numerical CT and Vx auxiliary voltage-powered overcurrent relay description	170
Ratings	171
Protection functions	172
Control & Monitoring	176
Setting ranges	178
Base unit	182
Presentation	182
Dimensions & weight	183
Description	184
Connection diagrams	185
Order form	187

Protection	ANSI	Overcurrent (Feeder, Incomer, Transformer or Generator)			Motor		Line Diff.	Voltage & Frequency (Busbar)		
		P122	P123	P127	P220	P225	P521	P921	P922	P923
Speed switch inputs	12/14				■	■				
Optional RTD	38/49T				6	10				
Phase under/over voltage (AND & OR mode)	27/59			■		■		■	■	■
Positive sequence under voltage	27D								■	■
Re-acceleration autorisation	27LV					■				
Wattmetric Earth Fault	32N/67W			■						
Undercurrent / Loss of load	37	■	■	■	■	■	■			
Broken conductor detection	46BC	■	■	■			■			
Negative phase sequence overcurrent	46	■	■	■	■	■	■			
Negative sequence overvoltage	47			■					■	■
Start / Stalled Protection / Motor Re-Acceleration	48/ 51LR				■	■				
Thermal overload	49	■	■	■	■	■	■			
Circuit breaker failure	50BF	■	■	■	■	■	■			
3-Phase overcurrent	50 / 51	■	■	■	■	■	■			
Earth overcurrent / Sensitive earth fault	50N / 51N	■	■	■	■	■	■			
Locked Rotor during Start-up	51S				■	■				
Voltage controlled overcurrent	51V			■						
Residual over voltage / Derived Vo sequence overvoltage	59N			■				■	■	■
High impedance restricted earth fault	64N	■	■	■						
Number of Starts Limitation	66				■	■				
Earth fault directional overcurrent	67N			■						
3 phase directional overcurrent	67P			■						
Autoreclose	79		■	■						
Under/over frequency	81U/O			■					■	■
Rate of change of Frequency (df/dt+t)	81R			■						■
Output relay latching	86	■	■	■	■	■	■	■	■	■
Phase segregated current differential protection	87P						■			
Current transformer supervision	CTS			■			■			
Circuit breaker fail protection	CBF	■	■	■	■	■	■			
CB commande (local Open / Close)		■	■	■						
Cold load pick-up	CLPU	■	■	■			■			
Trip Circuit Supervision	TCS	■	■	■	■	■	■			
Voltage transformer supervision	VTS/ 60			■					■	■
Switch on to fault	SOTF		■	■						
Control & Monitoring		P122	P123	P127	P220	P225	P521	P921	P922	P923
Emergency Restart					■	■				
Selective relay scheme logic		■	■	■	■	■	■	■	■	■
	Boolean logic equation	8	8	8	8	8	8	8	8	8
	AND / OR and NOT gates	■	■	■	■	■	■	■	■	■
CB Control & Monitoring (Local/ remote)			■	■	■	■	■		■	■
Setting Groups		2	2	8	2	2	2	1	2	2
Auxiliary timers		3	5	7/12*	10	10	5		5	5

*(option)

3

	Overcurrent (Feeder, Incomer, Transformer or Generator)			Motor		Line Diff.	Voltage & Frequency (Busbar)		
	P122	P123	P127	P220	P225	P521	P921	P922	P923
Measurement & records									
Measurements	■	■	■	■	■	■	■	■	■
Power and Energy Measurements			■		■				
Hours Run				■	■				
CB Operations	■	■	■	■	■	■	■	■	■
Disturbance Records up to number x 2.5 sec (backed-up)	5	5	5	5	5	5		5	5
Fault Records (backed-up)	25	25	25	25	25	25		25	25
Event Logging (backed-up)	250	250	250	250	250	250		250	250
Communication									
Front port (RS232)	■	■	■	■	■	■	■	■	■
Rear port (RS485)	■	■	■ / 2*	■	■	■	■	■	■
Rear Port Communication Protocol									
Modbus RTU	■	■	■	■	■	■	■	■	■
IEC 60870-5-103	■	■	■*	■	■	■	■	■	■
Hardware									
Digital inputs	3	5	7 / 12*	6	6	5	2	5	5
Outputs relays	6	8	8	6	6	8	4	8	8
4 fixed function LEDs and 4 programmable LEDs	■	■	■	■	■	■	■	■	■
1/5 dual rated AC Current inputs (settable)	■	■	■	■	■	■			
57....130 V AC Voltage inputs			3		1		4	4	4
General functions									
Test of output relays (Maintenance)	■	■	■					■	■
Inrush blocking/ restraint (menu selectable)	■	■	■			■			
Blocking logic	■	■	■			■	■	■	■
Phase rotation	■	■	■			■			
Intertripping (Direct, Permissive and Current differential)						■			
Propagation delay compensation						■			
3 Pole tripping only						■			
Fibre optic or metallic signalling channels						■			
Supervision of protection signalling channel						■			
Interchangeable protection signalling interface						■			
Vector Compensation (all vector groups)						■			
Ratio Correction						■			
Phase-to-neutral or phase-to-phase voltage protection							■	■	■
Settable hysteresis							■	■	■
Delta U / Delta T									■
Under voltage Blocking (settable for P923)									■
Time synchronisation (via digital input)	■	■	■			■		■	■
Time synchronisation (Modulated and Demodulated IRIG-B)			■						
Anti back-spin				■	■				■
									<i>*(option)</i>
Sensor inputs									
	P122	P123	P127	P220	P225	P521	P921	P922	P923
Each MiCOM series 20 has analog inputs that are connected to the measurement sensors required for the application.									
CT Inputs	4	4	4	4	4	4	-	-	-
VT inputs	-	-	3	-	1	-	4	4	4

3

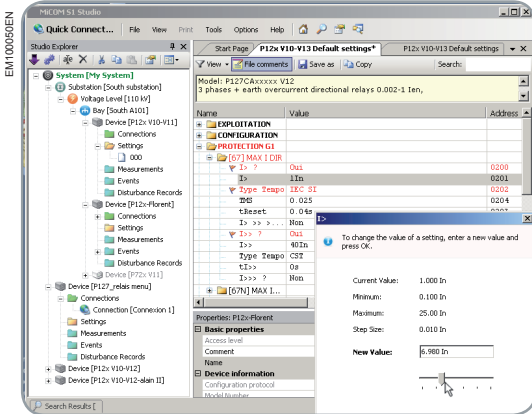

Simple function selection by mouseclick with MiCOM S1 Studio

MiCOM S1 Studio

All available functions, including protection, automation, communication, leds, inputs and outputs, are easily programmable through the user-friendly human machine interface and/or the MiCOM S1 Studio software.



Battery box MiCOM E2

Due to the lack of an RS232 communication port on modern PCs, the MiCOM E2 USB/RS232 cable is a must for all MiCOM relays users.

The MiCOM E2 performs the two following functions:

- Power MiCOM series 20 relays from the RS232 front port
 - When relays are not yet powered up before commissioning
 - When the auxiliary power supply of the relay is off or has failed
 - When no appropriate power supply is available (demonstration, exhibition ...)
- Access any MiCOM relays with MiCOM S1 Studio through the PC USB port (retrieve events/disturbance, remote measurements access, download/upload settings files/PSL ...)

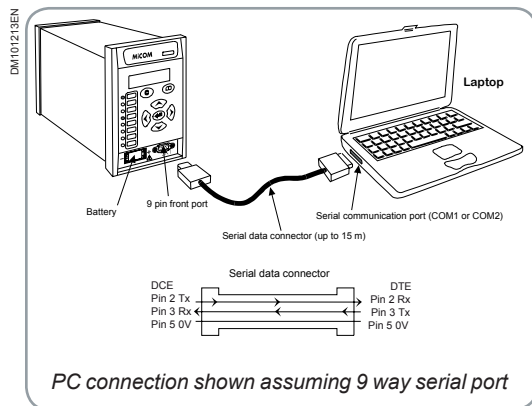

PC connection shown assuming 9 way serial port

RS232/RS232 cable

An RS232 cable can also be used to communicate to the relay. The RS232 cable allows the user to be able to read and change the settings or retrieve records and disturbance files of the relay when it is not powered by its auxiliary source.



Insulation withstand

Insulation	Standard	Value
Dielectric withstand	■ IEC 60255-5: 2000	2 kVrms 1 minute to earth and between independent circuits.
	■ IEEE C39.90:1989	1.5kV rms AC for 1 minute, (reaffirmed 1994) across normally open contacts
Impulse voltage	IEC 60255-5: 2000	5 kVp Between all terminals & all terminals and case earth
Insulation resistance	IEC 60255-5: 2000	> 1000 MΩ at 500 Vdc

Electrical environment

Insulation	Standard	Value
High frequency disturbance	IEC 60255-22-1:1998	Class 3 ■ 2.5 kV common mode ■ 1 kV differential mode
Fast transient	IEC 60255-22-4:2002	Class A ■ 2 kV 5kHz terminal block comms ■ 4 kV 2.5kHz all circuits excluding comms
	EN 61000-4-4:1995 Level 4	■ 2 kV 5kHz all circuits excluding power supply ■ 4 kV 5kHz power supply
Electrostatic discharge	■ EN 61000-4-2:1995 ■ IEC60255-22-2:1996	Class 4 ■ 8 kV contact discharge ■ 15kV air discharge
Surge Immunity	■ EN 61000-4-5:1995 ■ IEC 60255-22-5:2002	Level 4 ■ 4kV common mode, ■ 2kV differential mode
Conducted emissions	■ EN55022:1998 ■ IEC 60255-25:2000	■ 0.15-0.5MHz, 79dBμV (quasi peak) ■ 66 dBμV (average) ■ 0.5-30MHz, 73dBμV (quasi peak) ■ 60 dBμV (average)
Radiated emissions	■ EN55022:1998 ■ IEC 60255-25:2000	■ 30-230MHz, 40dBμV/m at 10m measurement distance ■ 230-1GHz, 47dBμV/m at 10m measurement distance
Conducted immunity	■ EN 61000-4-6:1996 ■ IEC 60255-22-6:2001	Level 3 ■ 10V rms @ 1kHz 80% am, 150kHz to 80MHz
Radiated Immunity	■ EN 61000-4-3:2002 ■ IEC 60255-22-3:2000	Level 3, ■ 10V/m 80MHz to 1GHz @ 1kHz 80% am
Radiated Immunity from digital telephones	EN 61000-4-3:2002	Level 4 ■ 30V/m 800MHz to 960MHz and 1.4GHz to 2GHz @ 1kHz 80% am
	ANSI/IEEE C37.90.2:2004	■ 2kV differential mode, level 4 35V/m 80MHz to 1GHz @ 1kHz 80% am ■ 35V/m 80MHz to 1GHz @ 100% pulse modulated front face only
Magnetic field immunity	EN 61000-4-8:1994	Level 5, ■ 2kV differential mode, level 4 100A/m applied continuously, 1000A/m for 3s
	EN 61000-4-9:1993	Level 5 ■ 1000A/m
	EN 61000-4-10:1993	Level 5 ■ 100A/m at 100kHz and 1MHz
ANSI Surge withstand capability	IEEE/ANSI C37.90.1:2002	Applied common and transverse mode ■ 4kV fast transient ■ 2.5kV damped oscillatory



(cont.)

Environment

Insulation	Standard	Value
Temperature	IEC 60255-6	Ambient temperature range
<ul style="list-style-type: none"> Operating temperature range 	Tested as per: <ul style="list-style-type: none"> IEC 60068-2-1: 2007 -25°C (-13°F) storage (96 hours) -40°C (-40°F) operation (96 hours)	-25°C to +55°C (or -13°F to +131°F)
<ul style="list-style-type: none"> Storage and transit 	<ul style="list-style-type: none"> IEC 60068-2-2: 2007 +85°C (+185°F) (storage (96 hours) +85°C (+185°F) operation (96 hours)	-25°C to +70°C (or -13°F to +158°F)*
(*) The upper limit is permissible for a Single 6 hour duration within any 24 hour period.		
Humidity	IEC 60068-2-78:2001	56 days at 93% RH and 40 °C
Enclosure protection	IEC 60-529: 2001	<ul style="list-style-type: none"> IP 52 Protection (front panel) against dust and dripping water IP 50 Protection for the rear and sides of the case against dust IP 10 Product safety protection for the rear due to live connections on the terminal block
Sinusoidal Vibrations	IEC 60255-21-1:1998	Response and endurance, class 2
Shocks	IEC 60255-21-2:1998	Response and withstand, class 1 & 2
Bump	IEC 60255-21-2:1998	Response and withstand, class 1
Seismic	IEC 60255-21-3:1998	Class 2
Creepage distances and clearances	IEC 60255-27: 2005	Pollution degree 2, Overvoltage category III, Impulse test voltage 5 kV
Corrosive Environments	Per IEC 60068-2-60: 1995, Part 2, Test Ke, Method (class) 3	Industrial corrosive environment / poor environmental control, mixed gas flow test. <ul style="list-style-type: none"> 21 days at 75% relative humidity and +30°C Exposure to elevated concentrations of H₂S, NO₂, Cl₂ and SO₂.

3

EU directive

EMC Directives	Standard
EMC Compliance  89/336/EEC 93/31/EEC	Compliance with the European Commission's EMC Directive Generic standards were used to establish conformity: <ul style="list-style-type: none"> EN50081-2: 1994 EN60952-2: 1995
Product Safety  2006/95/EC (replacing 73/23/EEC from 01/2007)	Compliance with the European Commission's Low Voltage Directive. Compliance is demonstrated by reference to generic safety standards : <ul style="list-style-type: none"> EN61010-1: 1993/A2: 1995 EN60950: 1992/A11: 1997

MiCOM P122 / P123 / P127

Three phase and earth fault overcurrent relays description



3

The MiCOM P122 / P123 / P127 relays provide features for easy adaptation and are suitable for all applications where overcurrent and earth-fault protection are required

Customer benefits



- Integration of function leading to cost-effective solution
- User friendly Human Machine Interface
- Highly flexible overcurrent relay with Boolean logic equation
- Multi-shot Autoreclose
- One single configuration software MiCOM S1 Studio
- Full set of measurement, metering & recording

The MiCOM P122 / P123 non-directional relays range up to the multifunction three phase and earth fault P123.

The MiCOM P127 directional relay ranges up to the multifunction three phase and earth fault, complete of voltage and frequency protection functions.

Users particularly appreciate the friendliness of the Human Machine Interface and the easy setting of the relays (that can be fully set through the front HMI or using MiCOM S1 Studio setting software).

In addition to their protection functions, MiCOM P122/P123/P127 provide full measurement and monitoring information necessary for efficient maintenance and post-fault analysis.

Several communication protocols allow easy interfacing of the relays in most of substation control or SCADA systems.

The MiCOM P122/P123/P127 are housed in the same draw out 4U metal case for panel or rack mounting with 20TE width (P122 and P123) or 30TE width (P127).

Application

MiCOM P122/P123/P127 relays provide a wide range of protection functions allowing their use in several applications:

- Main or backup protection on MV&HV systems
- Overhead lines and underground cables as a backup on HV systems
- Neutral systems protection (Insolated, solid earthed, resistance earthed and Petersen coil earthed)
- MV subscribers, Industry, Transport
- Generator and transformer scheme
- High impedance scheme for busbar and machine protection

Overview

The following functions are available in most of the devices:

- Measurement and metering
- Dynamic average values, max peak value and rolling demand for the current measurements
- Disturbance recording including all the CT/VT inputs and logic status
- Fault recording
- Event recording

Main functions

The MiCOM P122/P123/P127 protection relays are comprised of full suite of protection functions as well as automatic recloser and auxiliaries.

All available functions, including protection, automation, communication, leds, inputs and outputs, are easily programmable through the user-friendly human machine interface and/or the MiCOM S1 Studio software interface.

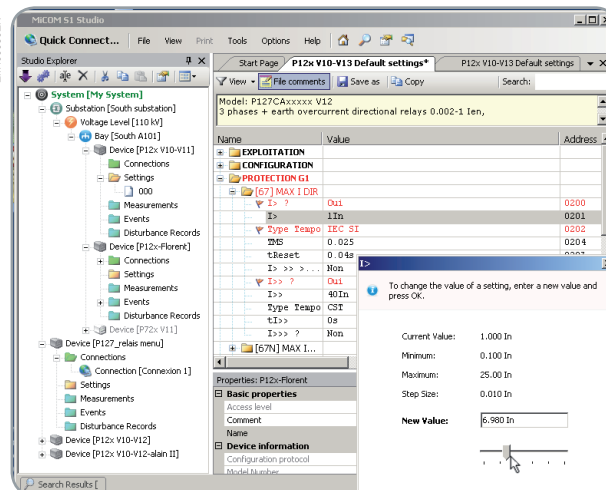

Simple function selection by mouseclick with MiCOM S1 Studio

Ratings

Power Supply	
Nominal auxiliary voltage V_x	24 - 250 Vdc / 48 - 240 Vac
Operating range	DC: $\pm 20\%$ of V_x AC: -20% , $+10\%$ of V_x
Residual ripple	Up to 12%
Stored energy time	≥ 50 ms for interruption of V_x
Burden	Stand by: $<3W$ DC or $<8VA$ AC
Frequency	
Frequency protection functions	From 45 to 65Hz
Nominal frequency	50/60Hz
Current inputs (AC inputs)	
Phase current inputs	1 and 5A by connection
Earth current inputs	1 and 5A by connection
Operating range	Selection by ordering code (Cortec)
Burden Phase Current	<ul style="list-style-type: none"> ■ $< 0.025VA$ (1A) ■ $< 0.3VA$ (5A)
Burden Earth Current	<ul style="list-style-type: none"> ■ $< 0.08VA$ (1A) ■ $< 0.42VA$ (5A)
Thermal withstand	<ul style="list-style-type: none"> ■ 1s @ 100 x rated current ■ 2s @ 40 x rated current ■ continuous @ 4 x rated current
R _{rp} (Impedance of relay phase current input at 30In)	<div style="display: flex; align-items: center;"> <div style="margin-right: 20px;">P127 only</div> <ul style="list-style-type: none"> ■ 25 m Ω (1A input) ■ 8 m Ω (5A input) </div>
R _{rn} (Impedance of relay neutral current input at 30In)	<ul style="list-style-type: none"> ■ 87 m Ω (1A input) ■ 15 m Ω (5A input)
Logic inputs	
Logic input burden	< 10 mAmps per input
Logic input recognition time	< 5 ms
Output relay characteristic	
Contact rating	
Contact relay	Dry contact Ag Ni
Make current	Max. 30A and carry for 3s
Carry capacity	5A continuous
Rated Voltage	250Vac
Breaking characteristic	
Breaking capacity AC	<ul style="list-style-type: none"> ■ 1500 VA resistive ■ 1500 VA inductive (P.F. = 0.5) ■ 220 Vac, 5A ($\cos \varphi = 0.6$)
Breaking capacity DC	<ul style="list-style-type: none"> ■ 135 Vdc, 0.3A (L/R = 30 ms) ■ 250 Vdc, 50W resistive or 25W inductive (L/R=40ms)
Operation time	< 7 ms
Durability	
Loaded contact	10000 operation minimum
Unloaded contact	100000 operation minimum

Ratings

(cont.)

Voltage inputs (P127 only)		
Voltage input range Un		<ul style="list-style-type: none"> ■ 57 to 130V ■ 220 to 480V
Operating range (measuring range)		<ul style="list-style-type: none"> ■ 0 to 260V ■ 0 to 960V
Burden	Resistive 44 k Ω	<ul style="list-style-type: none"> ■ 0.074W / 57V ■ 0.38W / 130V ■ 1.54W / 260V
	Resistive 438 k Ω	<ul style="list-style-type: none"> ■ 0.1102W / 220V ■ 0.525W / 480V ■ 2.1W / 960V
Thermal Withstand	Continuous	<ul style="list-style-type: none"> ■ 260V ph-ph ■ 960V ph-ph
	10 seconds	<ul style="list-style-type: none"> ■ 300V ph-ph ■ 1300V ph-ph

Functional overview

(Description of ANSI code nos., see Protection Function Overview table below)

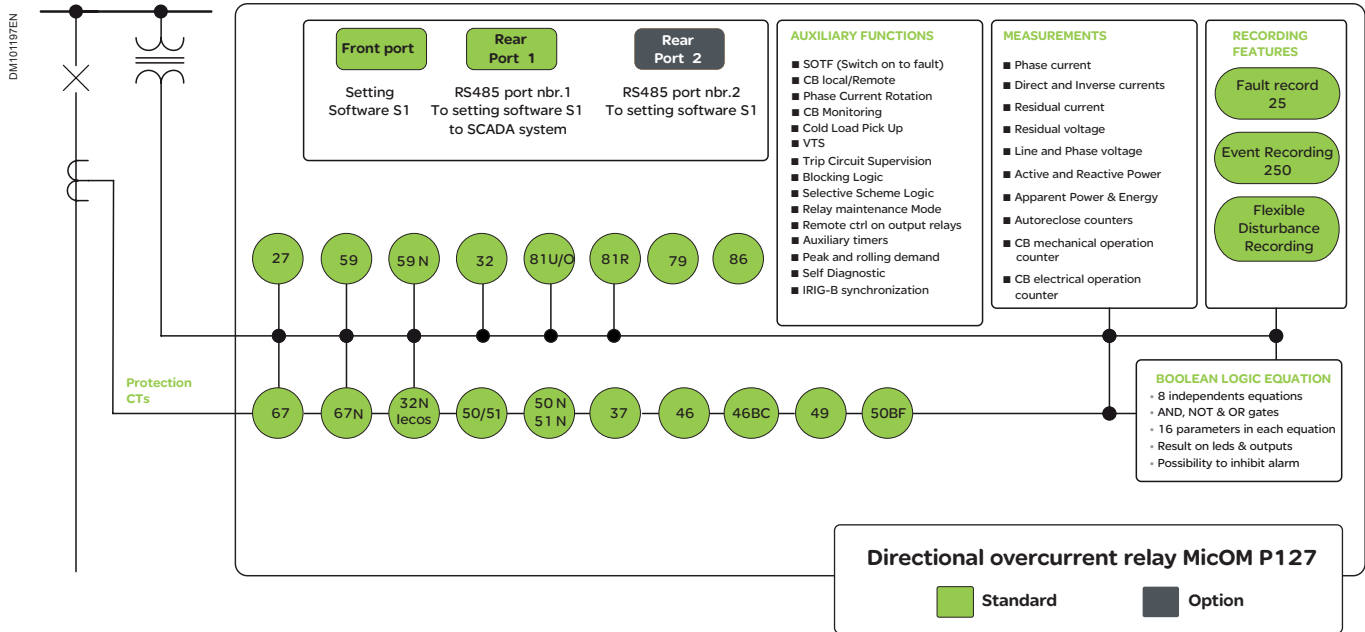

3

ANSI codes	Features	P122	P123	P127
27/59	Phase under/over voltage (AND & OR mode)			■
32N/67W	Wattmetric Earth Fault			■
37	Undercurrent / Loss of load	■	■	■
46BC	Broken conductor detection	■	■	■
46	Negative phase sequence overcurrent	■	■	■
47	Negative sequence overvoltage			■
49	Thermal overload	■	■	■
50N/51N	Earth overcurrent / Sensitive earth fault	■	■	■
50/51	3 Phase overcurrent	■	■	■
50BF	Circuit breaker failure	■	■	■
51V	Voltage controlled overcurrent			■
59N	Residual over voltage / Derived Vo sequence overvoltage			■
64N	High impedance restricted earth fault	■	■	■
67N	Earth fault directional overcurrent			■
67P	3 phase directional overcurrent			■
79	Autoreclose		■	■
81U/O	Under/over frequency			■
81R	Rate of change of Frequency (df/dt+t)			■
86	Output relay latching	■	■	■
CBF	Circuit breaker fail protection	■	■	■
	CB commande (local Open / Close)	■	■	■
CTS/VTS	Current transformer supervision / VT supervision			■
SOTF	Switch on to fault		■	■
TCS	Trip Circuit Supervision	■	■	■
CLPU	Cold load pick-up	■	■	■
	Inrush blocking	■	■	■
	Test of output relays (Maintenance)	■	■	■
	Selective relay scheme logic	■	■	■
	Phase rotation	■	■	■

General Features		P122	P123	P127
Number of digital inputs		3	5	7/12*
Total number of outputs relays		6	8	8
Events recording		250	250	250
Fault recording		25	25	25
Disturbance recording		5	5	5
Setting group		2	2	8
Auxiliary timers		3	5	7/12*
Number of RS485 port		1	1	1/2*
Communication	IEC60870-5-103 or Modbus RTU (port #1)	■	■	■
	Modbus or IEC60870-5-103 (port # 2)			□
Time synchronisation	Via rear communication port (DCS)	■	■	■
	Via digital input (external clock)	■	■	■
	Modulated and demodulated IRIG-B			□
Settings software	MiCOM S1 Studio using RS232 front port	■	■	■
Boolean logic equation	AND, OR and NOT gates (8 equations)	■	■	■
Measurements	RMS currents values & frequency	■	■	■
	Peak and rolling currents values	■	■	■
	Max and average measurements values	■	■	■
	Phase and/or neutral angle			■
	Power and Energy			■

Keys (□) (*) : optional

3

Three-Phase Overcurrent (50/51) & Earth Overcurrent (50N/51N)

Three independent stages are available either for phase and earth fault protection. For the first and second stage the user may independently select definite time delay (DTC) or inverse time delay (IDMT) with different type of curves (IEC, IEEE/ANSI, RI, RECT, EDF BPN). The third stage can be configured for peak detection and with definite time only. Each stage and related time delay can be programmed to provide maximum selectivity. The IDMT stages have reset definite or IDMT timer to reduce clearance times when intermittent faults occur.

A fourth earth overcurrent threshold based on derived earth current calculation is available on MiCOM P122, P123 and P127 (when no earth CT is available).

The MiCOM P122, P123 and P127 relays have separate instantaneous and delayed information for each stage. MiCOM P123 & P127 can indicate the phase(s) in fault by configuring output relays (first stage only)

Three-Phase & Earth-Fault Directional Overcurrent (67/67N)

Each of the three-phase overcurrent stages of P127 & earth fault stages of P127 can be independently configured as directional protection and with specific characteristic angle (RCA) and boundaries. The phase fault directional elements are internally polarised by quadrature phase to phase voltages. A synchronous polarising function is provided to ensure a correct operation of the overcurrent elements for close-up three phase faults where the collapse of the polarising line voltages occurs. In addition to the residual current, the residual voltage must be connected to a dedicated input or internally calculated as vector sum (P127 only) in order to make possible the directional operation of the earth-fault. Each earth-fault directional stage measures the residual current, the residual voltage, and the angle between residual voltage and current.

DM101185EN

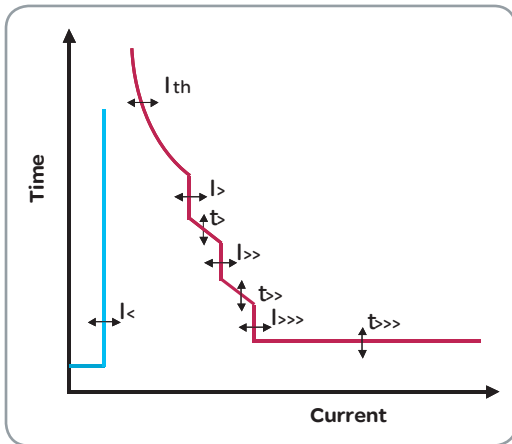

Tripping Characteristics

Thermal Overload (49)

Transformers and cables must be protected taking into account of their particular thermal characteristics. MiCOM P122, P123 and P127 relays include a thermal replica element based on the true RMS value of the current, up to 10th harmonic. Alarm and overload thresholds and time constant are fully programmable to match each application requirement.

High Impedance Restricted Earth-Fault (64N)

MiCOM P12x range offer the REF feature applied to enhanced ground fault detection on each transformer winding.

The relays ensure a high degree of stability against external fault conditions and a reliable performance against internal faults.

All the 50N/51N stages can be used for this application.

Negative Sequence Overcurrent (46)

The MiCOM P122, P123 and P127 relays include a programmable function specially designed to detect unbalanced load or fault conditions.

The three stages of negative sequence overcurrent have the same setting ranges and time delay as the phase overcurrent.

DM101185EN

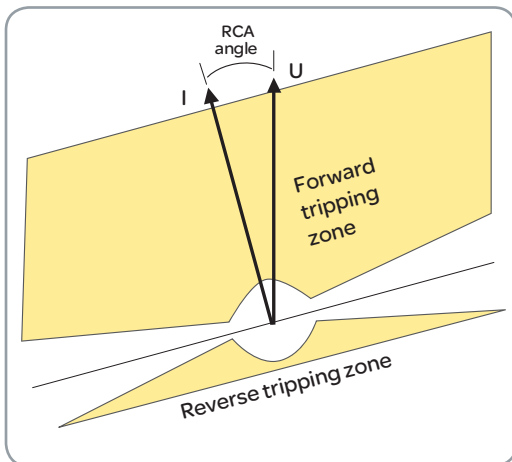

Directional Overcurrent Tripping Zone

Broken Conductor (46BC)

A typical unbalanced fault that can occur on the system is an open circuit fault. This fault can arise from broken conductor, discrepancy of one switchgear poles position or blowing of a fuse.

MiCOM P122, P123 and P127 relays are able to measure the ratio of negative to positive sequence current (I_2/I_1). This fully programmable function allows more sensitivity and stability than pure negative sequence measurement.

P127: Directional Power Protection (32)

MiCOM P127 relays provides a full set of directional power protection including two independants threshold for each of the following function :

- 3-phases under active power ($P <$, $P <<$)
- 3-phases over active power ($P >$, $P >>$)
- 3-phases under reactive power ($Q <$, $Q <<$)
- 3-phases over reactive power ($Q >$, $Q >>$)

Undercurrent Protection (37)

MiCOM P122, P123 and P127 relays provide a definite time undercurrent protection. This function allows typical applications such as loss of load or simple broken conductor detection.

DM101191EN

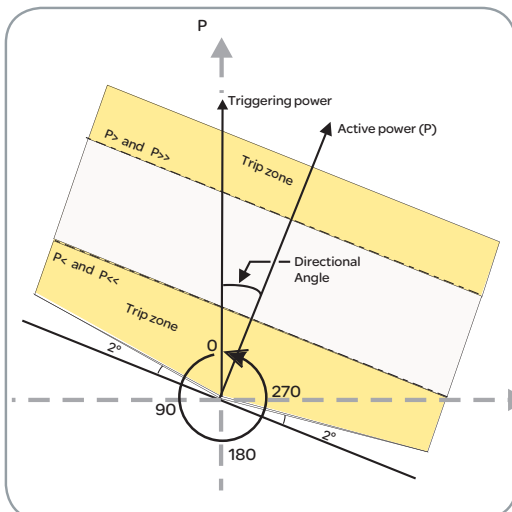

Directional Active Over / Under Protection

P127: Under / Over Voltage (27/59)

The P127 relay provides two independent under-voltage stages and two over-voltage stages. They are definite time elements. Each stage can be configured to operate from either phase-neutral or phase-phase voltages in single-phase mode (OR mode) or three-phase mode (AND mode).

P127: Under / Over Frequency (81U/O)

Time delayed under and over frequency protection available on P127 provides the fundamental form of frequency protection. When the frequency measured is crossing one of the 6 pre-defined thresholds, the relays generates a start signal and after a user settable time delay, a trip signal.



3

P127: Rate of Frequency (81R)

Time delayed rate of frequency protection in MiCOM P127 is used for severe disturbances when shedding load in small steps may not be sufficient. It can also complement the generator control system to reduce or shed generation when the frequency rises above the nominal frequency at a high rate.

P127: Residual overvoltage (59N)

P127 provides an additional residual over-voltage stage that can be used for generic earth faults detection, particularly in insulated neutral system or as backup at busbar level.

Circuit Breaker Failure Protection (50BF)

The circuit breaker failure verifies the effective opening of the CB by a dedicated undercurrent threshold. The circuit breaker failure function can be activated by trip of a generic protection or/and external command by the relevant digital input. The circuit breaker failure protection can be used for tripping upstream circuit breakers too.

P127: Voltage Controlled Overcurrent (51V)

The 51V function in P127 is a combination of $I >>$ and $U <$ functions to inhibit trip when normal generator current is already bigger than $I >>$ threshold:

- Overcurrent function trip will be inhibited if current is bigger than $I >>$ AND voltage greater than $U <$ (Generator ON => Live busbar).
- Overcurrent function will trip if current is bigger than $I >>$ AND voltage smaller than $U <$ (Generator OFF => dead MV busbar).

P127: Voltage Transformer Supervision (VTS)

P127 offer the possibility to monitor Voltage Transformer presence and could affect directional overcurrent. When VTS is detected, overcurrent function can be blocked or changed to a non directional overcurrent. Moreover, as soon as VTS is detected, all protection functions which needs voltage measure will be blocked (27 & 32N, for instance).

P127: Current Transformer Supervision (CTS)

Current transformer supervision is provided in MiCOM P127 to detect loss of phase CT based on zero sequence current occurrence combined with zero sequence voltage disappearance.

P123, P127: Switch on to Fault Protection

Closing of a circuit breaker might inadvertently lead to a short-circuit fault due to a maintenance ground clamp not yet removed. The MiCOM P123 and P127 relays incorporate configurable switch on to fault protection. It provides an instantaneous trip during a settable time after local or remote manual close, or after an automatic reclosing, or when triggered by a digital Input (downstream protection or 52A).

Selective Relay Scheme Logic

The MiCOM P122, P123 and P127 relays include selective relay scheme logic. A dedicated digital input can temporarily alter the time delay settings in response to the phase/earth fault start condition of a downstream relay. This function allows the MiCOM relays to quickly clear the fault when used in a cascade scheme.

Cold Load Pick-up

Cold load pick-up temporarily raises the setting of selectable stages closer to the load profile, avoiding unwanted trips.

Setting value can be increased by 800% during a settable duration. To trigger this function, either CB close position can be use or an automatic detection based on a sudden raise of current value.

DM10175EN

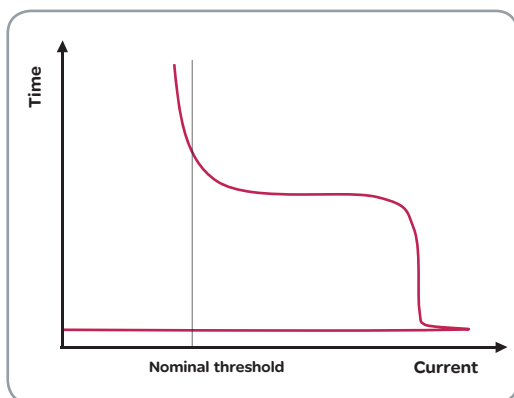

Cold-load characteristics

P123, P127: Autorecloser (79)

MiCOM P123 and P127 relays include a 4-shot triphase autorecloser. All the programmed protection functions may independently start any of the shots and the user can program which functions are allowed to trip after any of the shots. This makes possible special reclosing cycles e.g. as requested for coordination with fuses in distribution with tapped transformers.

To prevent excessive number of reclosing cycle in a short period of time, a setting can be used to define the maximum number of reclosing cycle allowed in a period of time after first one was detected. Dead and reclaim times are freely adjustable. A counter stores the number of reclose commands. This information is free locally or remotely. To inform operator that autorecloser has been blocked internally or externally, output relays can be assigned to these signals.

Outputs Contacts

Any outputs, including trip, can be latched. Reset of the latched outputs is possible by digital input, operator action on the Human Machine Interface or by remote communication (Digital Control System).

The two first output contacts (RL1 & RL2) can be used as failsafe relays to provide a "fail safe alarm" in case of power supply loss or major hardware failure. Other available relays can be inverted to reverse NO relays operating condition (output relays closing when logical state of the signal changes from 1 to 0).

Communication & Synchronization

The MiCOM P122, P123 and P127 relays offer a wide range of communication protocols, allowing its utilization in most of the network control and data acquisition systems (via Modbus, IEC 60870-5-103). It has been designed for permanent multidrop connection through the rear RS485 communication port. A second RS485 is optionally available on MiCOM P127 for maintenance purpose with Modbus or IEC 60870-5-103.

The MiCOM P122, P123 and P127 relays incorporate an internal clock to allow a 1ms accuracy time tagging of alarms, events, fault and disturbance record. To avoid any drifting of the time tagging clock, it's necessary to periodically synchronize the relays. To do this P122, P123 and P127 relays offer two solutions:

- Synchronization from the substation control system via the rear communication port
- Synchronization from an external GPS clock via a dedicated digital input
- Synchronization from an external GPS clock via a modulated or demodulated IRIG-B signal (P127 only)

3

Setting Groups

External conditions may request the need for different settings. MiCOM P122, P123 and P127 relays provide two independent setting groups. In MiCOM P127, up to 8 settings groups are available to have a flexible management of customer application schemes. Target settings change (1 to 8) should be performed by DCS or HMI since digital input status change can only switch from one group to another. Duplication facilities have been implemented to ease engineering work.

Circuit Breaker Command

To allow an easy and secured command of the circuit breaker through the HMI, a dedicated menu has been created in MiCOM P122, P123 and P127 relays. It's now possible to send a local open/close command through the HMI after operator confirmation.

Circuit Breaker Monitoring and Supervision

Circuit-breaker preventive maintenance is an advanced function provided by the MiCOM P122, P123 and P127 relays with adjustable closing and opening time measurements. All fault phase currents I1 or I2 are cumulated to inform about total interrupted current. These relays allow trip circuit supervision by using a specific input.

Event Recording

250 events are stored in MiCOM P122, P123 and P127 relays (even after a power supply loss) Events include inputs/outputs, change of status, alarms and contact operations. To upload them, it is possible to use the RS232 front port (MiCOM S1 Studio) or the rear serial port (DCS). Event records are stored on a non volatile flash memory.

Fault Recording

The last 25 faults are stored inside the MiCOM P122, P123 and P127 relays.

Each fault includes: Record number/ Fault time / Active setting group / Faulted phase / Protection operation / Magnitude of input quantities. Fault indicator helps the user to clearly identify the fault and to monitor relay setting and operations as all information are available on the relay HMI. Fault records are stored on a non volatile flash memory.

Disturbance Recording

Up to 5 disturbance files are stored in the relays. Even if the total duration is fixed to 15s, it can be fully adjustable for easy adaptation to customer requirements (1s / 3s / 5s / 7s / 9s). There are stored in COMTRADE format.

The disturbance recording function is triggered either by any of the programmed thresholds or by an external input, or through the communications. All digital and analogical information are stored in a flash memory and can be transferred using the front communication port or the rear port to be used by an external data analyser. Disturbance records are stored on a non volatile flash memory.

Boolean logic equation

The MiCOM P122/P123/P127 relays integrate complete logic equations to allow customization of the product based on customer application.

Up to 8 independent Boolean equations can be used. Each equation offers the possibility to use AND, OR & NOT logical gates. Up to 16 parameters can be used for each equation including any threshold and opto-input status. Every result of equation can be time delayed, reused in another equation (P127) and assigned to any output relays, trip, trip latching and/or HMI LEDs.

Each boolean equation result can be alarmed or not.

MiCOM S1 Studio Support Software

A Support Software MiCOM S1 Studio is available for the entire MiCOM family, including P122/P123/P127 relays.

S1 Studio is fully Windows™ compatible. This support Software allows easy setting of any MiCOM P122/P123/P127 model, preparing, storing, and retrieving setting files for further download on relay. In addition S1 Studio makes possible reading measurements and downloading event, fault and disturbance records for post-fault analysis purpose.

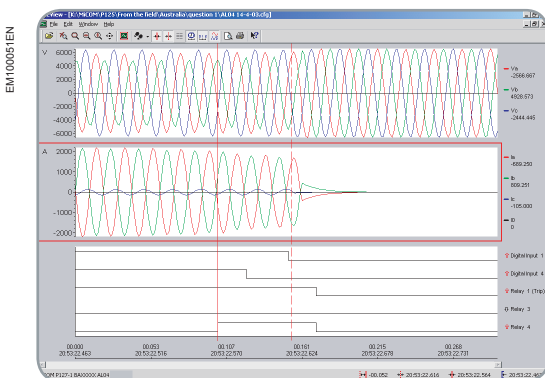

Example of disturbance record

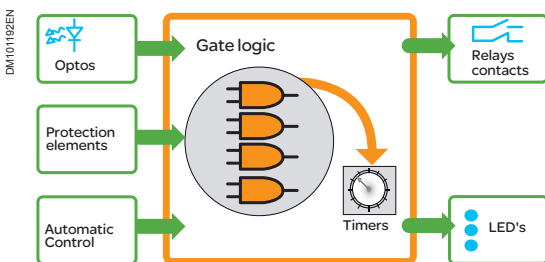

Protection functions setting ranges

Functions	Setting range		
	min.	max.	Steps
[27] Phase Undervoltage (P127 only)			
57–130V Input voltage			
U< ?	No or AND or OR		
U< tU<	2 V 0 s	130 V 600 s	0.1 V 0.01 s
52a Inhib. U< ?	Yes or No		
U<< ?	No or AND or OR		
U<< tU<<	2 V 0 s	130 V 600 s	0.1 V 0.01 s
52a Inhib. U<< ?	Yes or No		
[32] Directional Power (P127 only)			
57–130V Input voltage			
"P>?" or "Q>?" or "P<?" or "Q<?"	Yes or No		
P> or Q> or P< or Q<	1 W*k (*)	10000 W*k (*)	1 W*k (*)
Directional angle	0°	359°	1°
tP> or tQ> or tP< or tQ<	0 s	150 s	0.01 s
"P>>?" or "Q>>?" or "P<<?" or "Q<<?"	Yes or No		
P>> or Q>> or P<< or Q<<	1 W*k (*)	10000 W*k (*)	1 W*k (*)
Directional angle	0°	359°	1°
tP>> or tQ>> or tP<< or tQ<<	0 s	150 s	0.01 s
(*) k = 1 if TC secondary ration = 1A			
[32N] Earth Wattmetric (P127 only / Mode: Pe or IeCos)			
High sensitivity		Current input from 0.002 to 1 Ien	
57–130V Input voltage			
Pe> (*)	0.2xK W	20xK W	0.02xK W
Pe>> (*)	0.2xK W	20xK W	0.02xK W
Med. Sensitivity		Current input from 0.01 to 8 Ien	
57–130V Input voltage			
Pe> (*)	1xK W	160xK W	0.1xK W
Pe>> (*)	1xK W	160xK W	0.1xK W
Low sensitivity		Current input from 0.1 to 40 Ien	
57–130V Input voltage			
Pe> (*)	10xK W	800xK W	1xK W
Pe>> (*)	10xK W	800xK W	1xK W

Setting ranges

(cont.)

Functions	Setting range				
	min.	max.	Steps		
[32N] Earth Wattmetric (P127 only / Mode: Pe or leCos)					
Med. sensitivity leCos					
leCos>	0.01 len	8 len	0.005 len		
leCos>>	0.01 len	8 len	0.005 len		
Low sensitivity leCos					
leCos>	0.1 len	25 len	0.01 len		
leCos>>	0.5 len	40 len	0.01 len		
leCos> ?	Yes or No				
Delay Type	DT or IDMT (IEC_STI, IEC_SI, IEC_VI, IEC_EI, IEC_LTI, C02, C08, IEEE_MI, IEEE_VI, IEEE_EI, RI, RECT curve)				
tleCos>	0 s	150 s	0.01 s		
leCos> TMS	0.025	1.5	0.025		
leCos> Reset Delay Type	DT or IDMT				
leCos> RTMS	0.025	1.5	0.025		
leCos> tReset	0.00 s	100 s	0.01 s		
leCos>> ?	Yes or No				
tleCos>>	0 s	150 s	0.01 s		
leCos> tReset	0 s	100 s	0.01 s		
Pe/leCos Torque angle	0°	359°	1°		
[37] Under Current					
I< ?	Yes or No				
I<	P122 / P123	0.2 In	1 In	0.01 In	
	P127	0.1 In	1 In	0.01 In	
tI<	0 s	150 s	0.01 s		
I< Inhibited on 52A	Yes or No				
I< inhibited on U<	P127	Yes or No			
I< inhibited on U<		Yes or No			
[46] Negative Sequence Overcurrent					
I2> ?	No or Yes				
I2>	P122 / P123	0.1 In	40 In	0.01 In	
	P127	0.1 In	25 In	0.01 In	
Delay Type	DT or IDMT (IEC_STI, IEC_SI, IEC_VI, IEC_EI, IEC_LTI, C02, C08, IEEE_MI, IEEE_VI, IEEE_EI, RI, RECT curve)				
tI2>	0 s	150s	0.01s		
I2> TMS	P122 / P123	0.025	1.5	0.001	
	P127	0.025	1.5	0.025	
I2> Reset Delay Type	DT or IDMT				
I2> RTMS	0.025	1.5	0.025		
I2> tReset	0.04 s	100 s	0.01 s		
I2>> ?	No or Yes				
I2>>	P122 / P123	0.1 In	40 In	0.01 In	
	P127	0.5 In	40 In	0.01 In	
tI2>>	0 s	150s	0.01s		
I2>>> ?	P127	No or Yes			
I2>>>		0.5 In		40 In	0.01 In
tI2>>>		0 s		150s	0.01s

3

(cont.)

Functions	Setting range		
	min.	max.	Steps
[47] Negative Overvoltage (P127 only)			
57–130V Input voltage			
V2> ?	No or Yes		
V2>	1 V	130 V	0.1 V
tV2>	0 s	100 s	0.01 s
V2>> ?	No or Yes		
V2>>	1 V	130 V	0.1 V
tV2>>	0 s	100 s	0.01 s
[49] Thermal Overload			
Therm. OL ?	No or Yes		
I θ	0.1 I _n	3.2 I _n	0.01
T _e	1 mn	200 mn	1mn
K	1	1,5	0.01
θ Trip	50%	200%	1%
θ Alarm ?	No or Yes		
θ Alarm	50%	200%	1%
[51] Phase Overcurrent			
I> ?	No or Yes		
I>	0.1 I _n	25 I _n	0.01 I _n
Delay type	DT or IDMT (IEC_STI, IEC_SI, IEC_VI, IEC_EI, IEC_LTI, C02, C08, IEEE_MI, IEEE_VI, IEEE_EI, RI, RECT curve)		
tI>	0 s	150 s	0.01 s
I> TMS	0.025	1.5	0.001
I> Reset Delay Type	DT or IDMT		
I> RTMS	0.025	1.5	0.001
I> tReset	0 s	600 s	0.01 s
K (RI)	0.1	10	0.1
I> >> >> interlock	No or Yes		
I>> ?	No or Yes		
I>>	0.5 I _n	40 I _n	0.01 I _n
Delay type	DT or IDMT (IEC_STI, IEC_SI, IEC_VI, IEC_EI, IEC_LTI, C02, C08, IEEE_MI, IEEE_VI, IEEE_EI, RI, RECT curve)		
tI>>	0 s	150 s	0.01 s
I>> TMS	0.025	1.5	0.001
I>> Reset Delay Type	DT or IDMT		
I>> RTMS	0.025	1.5	0.025
I>> tReset	0.00 s	600 s	0.01 s
K (RI)	0.1	10	0.1
I>>> ?	No or Yes or Peak		
I>>> Sample	No or Yes		
I>>>	0.5 I _n	40 I _n	0.01 I _n
tI>>>	0 s	150 s	0.01 s

Setting ranges

(cont.)

Functions	Setting range		
	min.	max.	Steps
[50N/51N] Earth Overcurrent			
Med. sensitivity current set			
le>	0.01 len	2 len	0.005 len
le>>	0.01 len	8 len	0.005 len
le>>>	0.01 len	8 len	0.005 len
Low sensitivity current set			
le>	0.1 len	25 len	0.1 len
le>>	0.5 len	40 len	0.1 len
le>>>	0.5 len	40 len	0.1 len
le> ?	No or Yes		
Delay type	DT or IDMT (IEC_STI, IEC_SI, IEC_VI, IEC_EI, IEC_LTI, C02, C08, IEEE_MI, IEEE_VI, IEEE_EI, RI, RECT curve) or RXIDG (only for Cortec code P12-B-X---X)		
tle>	0 s	150 s	0.01 s
Interlock le>>>>	No or Yes		
K (RI)	0.1	10	0.1
le> TMS	0.025	1.5	0.001
le> Reset Delay Type	DT or IDMT		
le> RTMS	0.025	3.2	0.001
le> tReset	0 s	600 s	0.01 s
le>> ?	No or Yes		
Delay type	DT or IDMT (IEC_STI, IEC_SI, IEC_VI, IEC_EI, IEC_LTI, C02, C08, IEEE_MI, IEEE_VI, IEEE_EI, RI, RECT curve) or RXIDG (only for Cortec code P12-B-X---X)		
tle>>	0 s	150 s	0.01 s
K (RI)	0.1	10	0.1
le>> TMS	0.025	1.5	0.001
le>> Reset Delay Type	DT or IDMT		
le>> RTMS	0.025	3.2	0.001
le>> tReset	0.04 s	600 s	0.01 s
tle>>>	0 s	150	0.01 s
le>>> ?	No or Yes		
le>>> Sample	No or Yes		
tle>>>	0 s	150 s	0.01 s
le>>>> ?	No or Yes		
le>>>>	0.1 len	40 len	0.5 len
Delay type	DT or IDMT (IEC_STI, IEC_SI, IEC_VI, IEC_EI, IEC_LTI, C02, C08, IEEE_MI, IEEE_VI, IEEE_EI, RI, RECT curve) or RXIDG (only for Cortec code P12-B-X---X)		
tle>>>>	0 s	100 s	0.01 s
K (RI)	0.1	10	0.1
le>>>> TMS	0.025	1.5	0.001
le>>>> Reset Delay Type	DT or IDMT		
le>>>> RTMS	0.025	3.2	0.001
le>>>> tReset	0.04 s	600 s	0.01 s
tle>>>>	0 s	150	0.01 s

MiCOM P122 / P123 / P127

Setting ranges

(cont.)

Functions	Setting range		
	min.	max.	Steps
[59] Phase Overvoltage (P127 only)			
57–130V Input voltage			
U> ?	No or AND or OR		
U>	2 V	260 V	0.1 V
tU>	0 s	260 s	0.01 s
U>> ?	No or AND or OR		
U>>	2 V	260 V	0.1 V
tU>>	0 s	600 s	0.01 s
[59] Residual Overvoltage (P127 only)			
57–130V Input voltage			
Ue>>>> ?	No or Yes		
Ue>>>>	1 V	260 V	0.1 V
tUe>>>>	0 s	600 s	0.01 s
<p><i>ATTENTION: The Ue threshold settings depend on the adopted connection option. In configuration/general options menu of the P127 relay the Ue input can be set directly from a VT (i.e. from a delta VT) or can be derived from the measurement of the three phase to neutral voltages (3VPN). In this case the Ue is calculated as: $U_e = 1/3 \times (U_A + U_B + U_C)$. The setting of the Ue thresholds must take this formula in account.</i></p>			
[67] Directional Overcurrent (P127 only)			
I> ?	No or Yes or DIR		
I>	0.1 I _n	25 I _n	0.01 I _n
Delay type	DT or IDMT (IEC_STI, IEC_SI, IEC_VI, IEC_EI, IEC_LTI, C02, C08, IEEE_MI, IEEE_VI, IEEE_EI, RI, RECT curve)		
tI>	0 s	150 s	0.01 s
I> TMS	0.025	1.5	0.001
I> Reset Delay Type	DT or IDMT		
I> RTMS	0.025	3.2	0.025
I> tReset	0 s	100 s	0.01 s
I> I>> I>>> Interlock	No or Yes		
I> Torque angle	0°	359°	1°
I> Trip zone	±10°	±170°	1°
I>> ?	No or Yes or DIR		
I>>	0.1 I _n	40 I _n	0.01 I _n
Delay type	DT or IDMT (IEC_STI, IEC_SI, IEC_VI, IEC_EI, IEC_LTI, C02, C08, IEEE_MI, IEEE_VI, IEEE_EI, RI, RECT curve)		
tI>>	0 s	150 s	0.01 s
I>> TMS	0.025	1.5	0.001
I>> Reset Delay Type	DT or IDMT		
I>> RTMS	0.025	3,2	0.025
I>> tReset	0 s	100 s	0.01 s
I>> Torque angle	0°	359°	1°
I>> Trip zone	±10°	±170°	1°
I>>> ?	No or Yes or DIR or Peak		
I>>>	0.1 I _n	40 I _n	0.01 I _n
tI>>>	0 s	150 s	0.01 s
I>>> Torque angle	0°	359°	1°
I>>> Trip zone	±10°	±170°	1°

MiCOM P122 / P123 / P127

Setting ranges

(cont.)

Functions	Setting range		
	min.	max.	Steps
[67N] Earth Fault Directional Overcurrent (P127 only)			
Med. sensitivity current set			
le>	0.01 len	1 len	0.005 len
le>>	0.01 len	8 len	0.005 len
le>>>	0.01 len	8 len	0.005 len
le_d>	0.1 len	40 len	00.01 len
le_d>>	0.1 len	40 len	00.01 len
Low sensitivity current set			
le>	0.1 len	25 len	0.1 len
le>>	0.5 len	40 len	0.1 len
le>>>	0.5 len	40 len	0.1 len
le_d>	0.1 len	40 len	00.01 len
le_d>>	0.1 len	40 len	00.01 len
le> ?	No or Yes or DIR		
Delay type	DT or IDMT (IEC_STI, IEC_SI, IEC_VI, IEC_EI, IEC_LTI, C02, C08, IEEE_MI, IEEE_VI, IEEE_EI, RI, RECT curve)		
tIe>	0 s	150 s	0.01 s
Ie> TMS	0.025	1.5	0.025
Ie> Reset Delay Type	DT or IDMT		
Ie> RTMS	0.025	3.2	0.025
Ie> tReset	0 s	100 s	0.01 s
Ie> Ie>> Ie>>> Interlock	No or Yes		
Ie> Torque angle	0°	359°	1°
Ie> Trip zone	±10°	±170°	1°
Input residual voltage with range from 57 to 130V			
Ue>	1 V	260 V	0.1 V
Ue>>	1 V	260 V	0.1 V
Ue>>>	1 V	260 V	0.1 V
Ue(Ie_d>)	1 V	260 V	0.1 V
Ue(Ie_d>>)	1 V	130 V	0.1 V

ATTENTION: The Ue threshold settings depend on the adopted connection option. In configuration/general options menu of the P127 relay the Ve input can be set directly from a VT (i.e. from a delta VT) or can be derived from the measurement of the three phase to neutral voltages (3VPN). In this case the ue is calculated as: $U_e = 1/3 \times (U_A + U_B + U_C)$. The setting of the Ue thresholds must take this formula in account.

MiCOM P122 / P123 / P127

Setting ranges

(cont.)

Functions	Setting range		
	min.	max.	Steps
[79] Autoreclose (P123 / P127 only)			
Autoreclose ?	Yes or No		
Ext. CB Fail ?	Yes or No		
Ext. CB Fail time	0.01 s	600 s	0.01 s
Aux1 ((I>) ?	P127	Yes or No	
Aux2 (Ie>) ?		Yes or No	
Ext Block ?	Yes or No		
Rolling Demand	Yes or No		
Max cycles nb	2	100	1
Time period	10mn	24h	10mn
Dead time			
tD1	0.01 s	300 s	0.01 s
tD2	0.01 s	300 s	0.01 s
tD3	0.01 s	600 s	0.01 s
tD4	0.01 s	600 s	0.01 s
Minimum drop off time			
tI>	0.05 s	600 s	0.01 s
tI>>	0.05 s	600 s	0.01 s
tI>>>	0.05 s	600 s	0.01 s
tIe>	0.05 s	600 s	0.01 s
tIe>>	0.05 s	600 s	0.01 s
tIe>>>	0.05 s	600 s	0.01 s
Reclaim time tR	0.02 s	600 s	0.01 s
Inhib time tI	0.02 s	600 s	0.01 s
Phase Cycles	0	4	1
E/Gnd Cycles	0	4	1
Cycles	4 3 2 1	Settings	
tI>	P123 / P127	1 1 1 1	0 or 1 or 2 or 3 or 4
tI>>	P123 / P127	1 1 1 1	0 or 1 or 2 or 3 or 4
tI>>>	P123 / P127	1 1 1 1	0 or 1 or 2 or 3 or 4
tIe>	P123 / P127	1 1 1 1	0 or 1 or 2 or 3 or 4
tIe>>	P123 / P127	1 1 1 1	0 or 1 or 2 or 3 or 4
tIe>>>	P123 / P127	1 1 1 1	0 or 1 or 2 or 3 or 4
tPe/Iecos>	P127	1 1 1 1	0 or 1 or 2 or 3 or 4
tPe/Iecos>>		1 1 1 1	0 or 1 or 2 or 3 or 4
tAux1	P123 / P127	1 1 1 1	0 or 1 or 2 or 3 or 4
tAux2	P123 / P127	1 1 1 1	0 or 1 or 2 or 3 or 4

0 = no action on autorecloser : definitive trip
 1 = trip on pick up of the protection element, followed by reclosing cycle
 2 = no trip on pick up of the protection element also if this has been set in the CRTL/Trip commands/Trip menu.
 3 = autoreclose without trip (trip order inhibited, no trip order from autoreclose function).



Setting ranges

(cont.)

OP Parameters	Setting range		
	min.	max.	Steps
Frequency	50 Hz	60 Hz	N.A
[81] Frequency (P127 only)			
F1?	81> or 81< or No		
F1	45,1 Hz	64,9 Hz	0.01 Hz
tF1	0 s	600 s	0.01 s
F2?	81> or 81< or No		
F2	45,1 Hz	64,9 Hz	0.01 Hz
tF2	0 s	600 s	0.01 s
F3?	81> or 81< or No		
F3	45,1 Hz	64,9 Hz	0.01 Hz
tF3	0 s	600 s	0.01 s
F4?	81> or 81< or No		
F4	45,1 Hz	64,9 Hz	0.01 Hz
tF4	0 s	600 s	0.01 s
F5?	81> or 81< or No		
F5	45,1 Hz	64,9 Hz	0.01 Hz
tF5	0 s	600 s	0.01 s
F6?	81> or 81< or No		
F6	45,1 Hz	64,9 Hz	0.01 Hz
tF6	0 s	600 s	0.01 s
Rate of change of frequency (P127 only)			
dF/dt1 ?	Yes or No		
dF/dt1	-10Hz/s	+10Hz/s	0.1Hz/s
dF/dt2 ?	Yes or No		
dF/dt2	-10Hz/s	+10Hz/s	0.1Hz/s
dF/dt3 ?	Yes or No		
dF/dt3	-10Hz/s	+10Hz/s	0.1Hz/s
dF/dt4 ?	Yes or No		
dF/dt4	-10Hz/s	+10Hz/s	0.1Hz/s
dF/dt5 ?	Yes or No		
dF/dt5	-10Hz/s	+10Hz/s	0.1Hz/s
dF/dt6 ?	Yes or No		
dF/dt6	-10Hz/s	+10Hz/s	0.1Hz/s

Setting ranges

(cont.)

Control & monitoring functions
setting ranges

Functions	Setting range		
	min.	max.	Steps
Inrush blocking Logic			
Inrush Block	Yes or No		
Inrush H2 ration	10 %	35 %	0,1 %
Inrush tReset	0 ms	2 s	0,1 s
Block I>	No	Yes	Yes or No
Block I>>	No	Yes	Yes or No
Block I>>>	No	Yes	Yes or No
Block Ie>	No	Yes	Yes or No
Block Ie>>	No	Yes	Yes or No
Block Ie>>>	No	Yes	Yes or No
Block I2>	No	Yes	Yes or No
Block I2>>	No	Yes	Yes or No
Block I2>>>	No	Yes	Yes or No
Block Ie_d>, Ie_d>>	No	Yes	Yes or No
Logic selectivity			
Sel1 tI>>	Yes or No		
Sel1 tI>>>	Yes or No		
Sel1 tIe>>	Yes or No		
Sel1 tIe>>>	Yes or No		
Sel1 tIe>>>>	P122 / P123	Yes or No	
Sel1 tIe_d>	P127	Yes or No	
Sel1 tIe_d>>		Yes or No	
T Sel1	0s	150s	10ms
Inrush blocking Logic			
tAux1	0	200 s	0.01 s
tAux2	0	200 s	0.01 s
tAux3	0	200 s	0.01 s
tAux4	0	200 s	0.01 s
tAux5	0	200 s	0.01 s
tAux6	P127	0	200 s
tAux7		0	20000 s
tAux8		0	20000 s
tAux9		0	20000 s
tAuxA (tAux10)		0	200 s
tAuxB (tAux11)		0	200 s
tAuxC (tAux12)		0	200 s
Broken Conductor			
Brkn.Cond ?	Yes or No		
Ratio I2/I1	20%	100%	1%
Brkn.Cond Time tBC	1s	14400s	1s

Setting ranges

(cont.)

Functions	Setting range		
	min.	max.	Steps
Cold Load PU			
Cold Load pickup activable with: tI>, tI>>, tI>>>, tIe>, tIe>>, tIe>>>, tIe_d, tIe_d>>, tI2>, tI2>>, tI2>>> and/or tTherm			
Cold Load PU ?	Yes or No		
Input?	Yes or No		
Auto?	Yes or No		
Cold Load PU level	20%	800%	1%
tCL	0.1s	3600s	0.1s
CB Fail			
CB Fail ?	Yes or No		
I<	0.02 In	1In	0.01 In
CB Fail Time tBF	10 ms	10 s	0.01 s
Block I>	No	Yes	Yes or No
Block Ie>	No	Yes	Yes or No
TC Supervision			
TC Supervision ?	Yes or No		
t trip circuit tSUP	0.1 s	10 s	0.01 s
CB Supervision			
CB Open S ^o ffvision?	Yes or No		
CB Open time	0.05 s	1 s	0.01 s
CB Close S ^o ffvision?	Yes or No		
CB Close time	0.05 s	1 s	0.01 s
CB Open Alarm ?	Yes or No		
CB Open NB	0	50000	1
Σ Amps(n) ?	Yes or No		
Σ Amps(n)	0 E6 A	4000 E6 A	1E6 A
n	1	2	1
tOpen Pulse(*)	0.10 s	5 s	0.01 s
tClose Pulse(*)	0.10 s	5 s	0.01 s
<i>NOTE: The tOpen/Close Pulse is available in the P123 for the Local /Remote functionality</i>			
SOTF/TOR Switch on to fault / Trip on reclose (P123 & P127 only)			
SOTF?	Yes or No		
t SOTF	0 ms	500 ms	10ms
I>>	Yes or No		
I>>>	Yes or No		
Ctrl close input	Yes or No		
SOTF input	Yes or No		
HMI closing order	Yes or No		
[79] closing	Yes or No		
Front comm. order	Yes or No		
Rear comm. order	Yes or No		
Rear2 comm. order	P127	Yes or No	

3

(cont.)

Functions	Setting range		
	min.	max.	Steps
Timer Setting Ranges - Logic equat T delay			
EQU. A Toperat	0 s	600 s	0.01 s
EQU. A Treset	0 s	600 s	0.01 s
EQU. B Toperat	0 s	600 s	0.01 s
EQU. B Treset	0 s	600 s	0.01 s
EQU. C Toperat	0 s	600 s	0.01 s
EQU. C Treset	0 s	600 s	0.01 s
EQU. D Toperat	0 s	600 s	0.01 s
EQU. D Treset	0 s	600 s	0.01 s
EQU. E Toperat	0 s	600 s	0.01 s
EQU. E Treset	0 s	600 s	0.01 s
EQU. F Toperat	0 s	600 s	0.01 s
EQU. F Treset	0 s	600 s	0.01 s
EQU. G Toperat	0 s	600 s	0.01 s
EQU. G Treset	0 s	600 s	0.01 s
EQU. H Toperat	0 s	600 s	0.01 s
EQU. H Treset	0 s	600 s	0.01 s
Logic equat T delay - Communication order delay (P127 only)			
tCommand 1	0s	600s	50ms
tCommand 2	0s	600s	50ms
tCommand 3	0s	600s	50ms
tCommand 4	0s	600s	50ms
51V Function - P127 only			
Voltage range 57-130V			
(U<OR V2>) & l>>	Yes or No		
V2>	3V	200V	0.1V
(U<<OR V2>>) & l>>>	Yes or No		
V2>	3V	200V	0.1V
VT Supervision - P127 only			
VTS?	Yes or No		
VTS Alarm	Yes or No		
VTS Blocks 51V	Yes or No		
VTS Blocks protection ?	Yes or No		
VTS Non Dir l>, l>>, l>>>, le>, le>>, le>>>, le_d> and/or le_d>>	Yes or No		
tVTS	0s	100s	10ms
CT Supervision - P127 only			
CT Supervision	Yes or No		
le>	0.08 °— In	1.0 °— In	0.01 °— In
Ue< (P127xA)	0.5V	22V	0.1V
Ue< (P127xB)	2V	88V	0.5V
tCTS	0s	100s	0.01s

MiCOM P122 / P123 / P127

Setting ranges

(cont.)

Logical gates	Availability
NOT	A00
	B00
	C00
	D00
	E00
	F00
	G00
	H00
OR (by default)	A01 to A15
AND	B01 to B15 C01 to C15
AND NOT	D01 to D15
OR NOT	E01 to E15 F01 to F15 G01 to G15 H01 to H15

3

Recording functions setting ranges

Event Records	
Capacity	250 events
Time-lag	1 millisecond
Triggers	<ul style="list-style-type: none"> ■ Any selected protection alarm and threshold ■ Logic input change of state ■ Setting changes ■ Self test events

Instantaneous recorder	
Capacity	25 faults
Time-lag	1 millisecond
Triggers	Any selected protection alarm and threshold
Data	<ul style="list-style-type: none"> ■ Date, hour ■ Origin (any protection alarm) ■ Length (duration of the instantaneous trip yes or no)

Fault Records	
Capacity	5 starting informations (instantaneous)
Time-lag	1 millisecond
Triggers	Any selected protection alarm and threshold
Data	<ul style="list-style-type: none"> ■ Fault date ■ Protection thresholds ■ Setting Group ■ AC inputs measurements (RMS) ■ Fault measurements

Disturbance Records				
Triggers	<ul style="list-style-type: none"> ■ Any selected protection alarm and threshold ■ Logic input, ■ Remote command 			
Data	<ul style="list-style-type: none"> ■ Data AC input channels ■ Digital input and output states ■ Frequency value 			
Function	Default value	Setting range		
		Min	Max	Step
Records number	5	1	5	1
Pre-Time	0.1s	0.1	2.9 / 4.9 / 6.9 or 8.9	0.1
Disturb rec Trig	ON TRIP	ON TRIP or ON INST.		
Trigger	<ul style="list-style-type: none"> ■ Any selected protection alarm and threshold ■ Logic input ■ Remote command 			

Presentation



User-Machine Interface (HMI)

All functions, including protection, automation, communication, LEDs, inputs and outputs, can be programmed and modified using the front panel user interface (Human Machine Interface).

The backlit LCD informs the user about settings, measurements & faults thanks to the pull-down structure menu allowing easy and quick access to any data.

Working language

The following languages can be settable in most of the relays:

- French, English, Spanish, Portuguese, Turkish, Polish, Russian, Chinese, Dutch, German, Italian, Czech, Hungarian and Greek.

Wiring

Connection of power terminals, and Signals terminals

The individual equipment are delivered with sufficient M4 screws to connect the relay via annular terminals, with a maximum recommended of two annular terminals per contact.

Terminals	Wire size
Push-on connector : 4.8 x 0.8mm	0.75 - 1.5 mm ²
Push-on connector : 4.8 x 0.8mm	1.5 - 2.5 mm ²
M4 90° Ring Tongue terminal	0.25 - 1.65 mm ²
M4 90° Ring Tongue terminal	1.5 - 2.5 mm ²

Communication

Communication software: MiCOM S1 Studio.

Type Port	Physical Link	Connectors	Data Rate	Comms. mode	Protocol
RS485 Rear port	Screened twister pair	Screws or snap-on	■ 300 to 38400 baud (programmable)	■ Data Bit: 8 ■ Stop bit: 1/ 2	■ ModBus RTU ■ IEC60870-5-103
RS485 isolated (P127 Optional 2nd rear port)	Screened twister pair	Screws or snap-on	■ 300 to 38400 baud (programmable)	■ Parity: None/Odd/Even ■ Address: 1 to 254	■ ModBus RTU ■ IEC60870-5-103 (option)
USB / RS232 Front port	Screened twister pair	PC: 9 pin D-type male connector P122/123/127: Sub-D 9 pin female connectorr	■ 300 to 38400 baud (programmable)	■ Data Bit:8 ■ Stop bit: 1 ■ Parity: None ■ Address: 1	■ ModBus RTU

IRIG-B interface (P127 only)

The IRIG-B is a P127 optional interface used to receive synchronization signal from a GPS clock.

Modulated (1kHz)	No modulated
■ BNC socket and BNC adaptor ■ total impedance: 50Ω	■ Screw ■ SELV rated circuit ■ Date code: BCD



Dimensions & weight

MiCOM P122 / P123

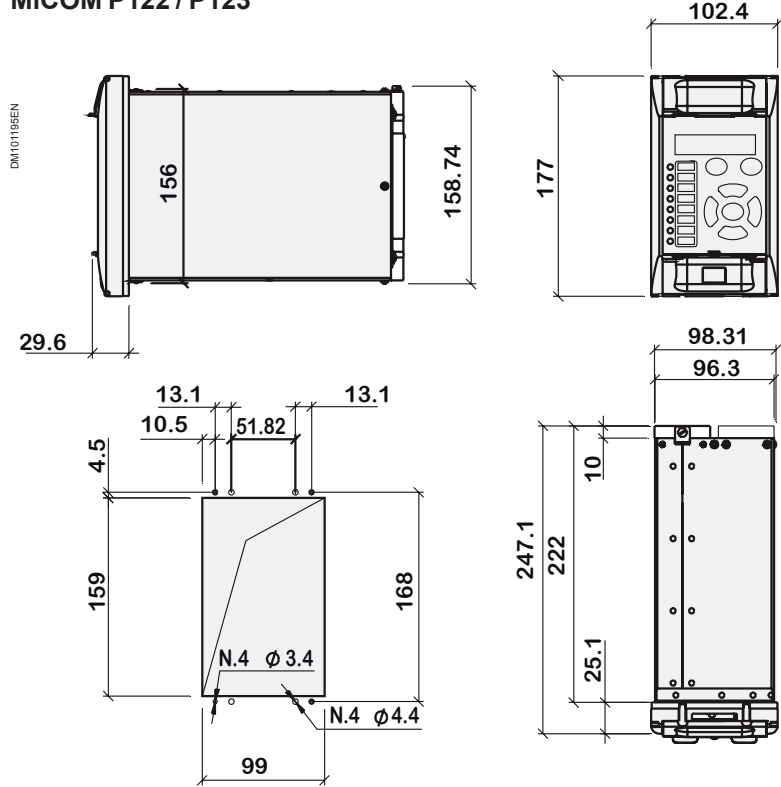

P122 / P123

■ Height	177 mm
■ Width	102.4 mm (20TE)
■ Depth	247.1 mm
■ Weight	approx. 2 Kg

Hardware and Case

P122/P123/P127 are based on advanced numerical technology. All the models of the MiCOMP122/P123/P127 have a 4U draw out metal case, and can be flush-mounted in switchboard or panel or rack-mounted.

All the CT inputs are automatically short-circuited as soon as the active unit is withdrawn in its case.

To insure a compliance with any auxiliary voltage source and minimize variants, a universal power supply board from 24 to 250Vac/dc is available along the MiCOM P122/P123/P127 range.

Wiring

External connections are made via MIDOS type terminal blocks. Each connection includes two 4.8 mm Faston and one M4 screw fixing. The wiring for all the MiCOM P122/P123/P127 are standard to provide maximum compatibility.

P127

■ Height	177mm
■ Width	154,2 mm (30TE)
■ Depth	247,1 mm
■ Weight	approx. 4 Kg

MiCOM P127

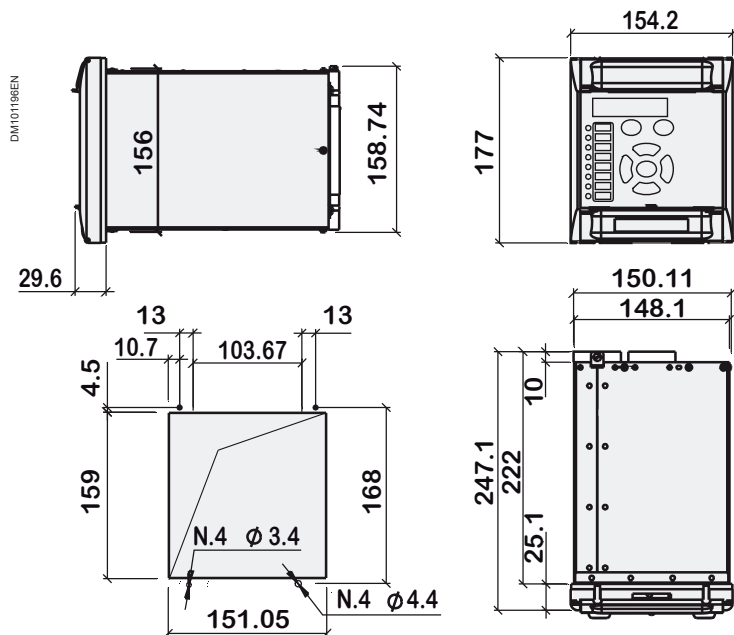

Note: For P127 with IRIG-B option with BNC adaptor, add 25 mm to the length.

MiCOM P122 / P123 / P127 Base Unit

(cont.)

Front panel description

- 1 Top cover
- 2 Clear key)
- 3 Read key
- 4 Key pad (cursor keys)
- 5 Fixed function LEDs
- 6 User programmable function LEDs
- 7 Plastic cover
- 8 Battery (not used)
- 9 Comms front port (RS232)

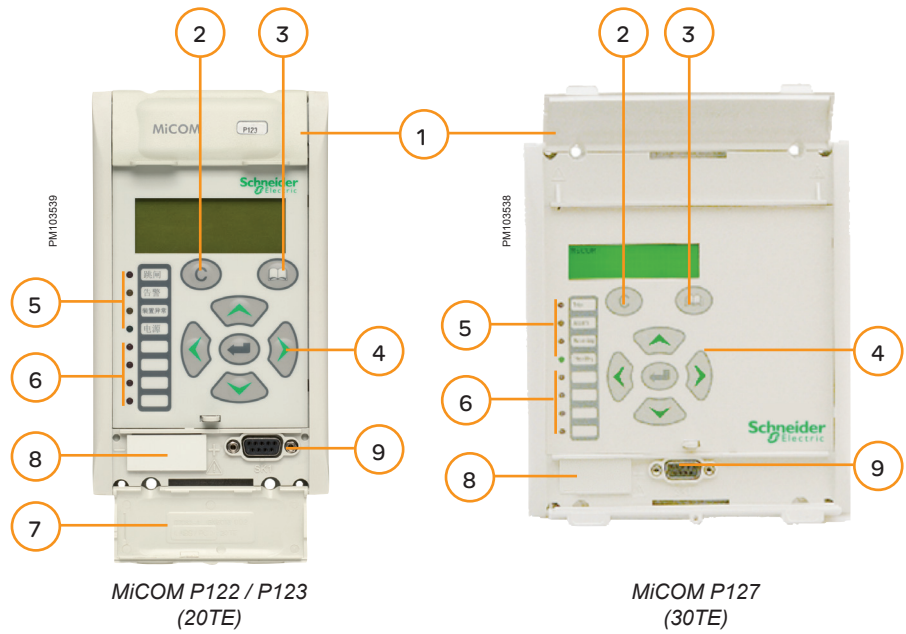

MiCOM P122 / P123 / P127

Base Unit

(cont.)

P122/P123: Advice for external connections

Scheme representing micom relay off

DM101155EN

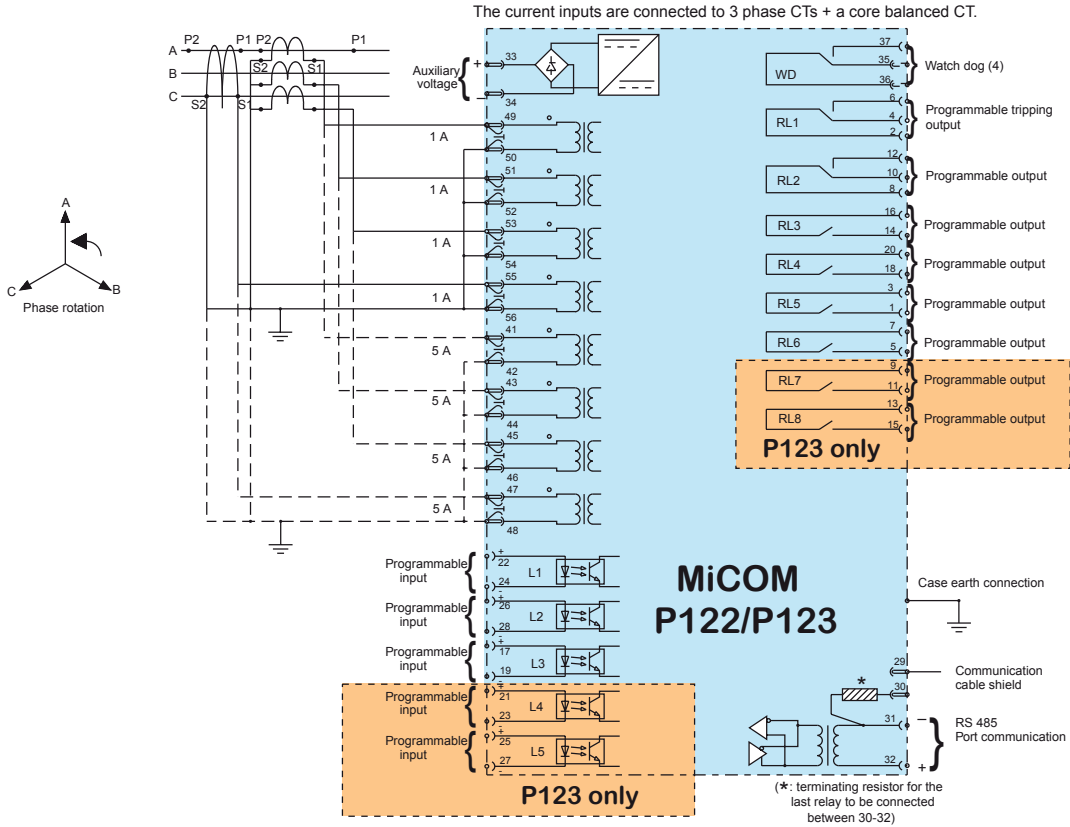

Nota :

- (1) (a) CT shorting links make before (b) and (c) disconnect
- (b) Short terminals break before (c)
- (c) Long terminals
- (d) Pins terminals (pcb type)

- (2) CT connection are typical only
- (3) Earth terminals are typical only
- (4) The MiCOM P122/P123 relays are shown with supply off.

Alternative :

The earth current input is connected to the summation of the three phase CTs.

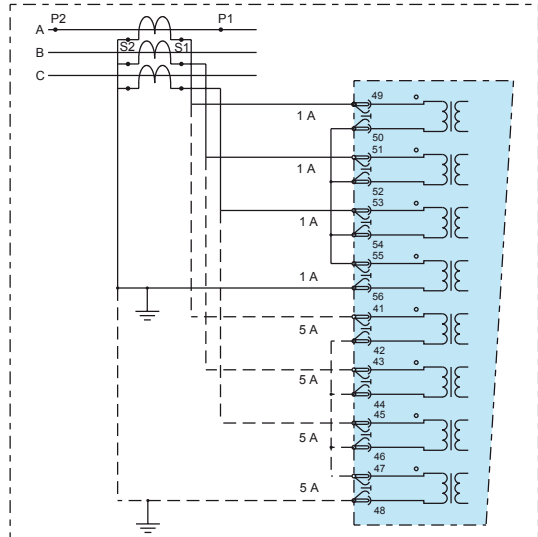

Alternative :

Connection to 2 phases CTs + a core balanced CT.

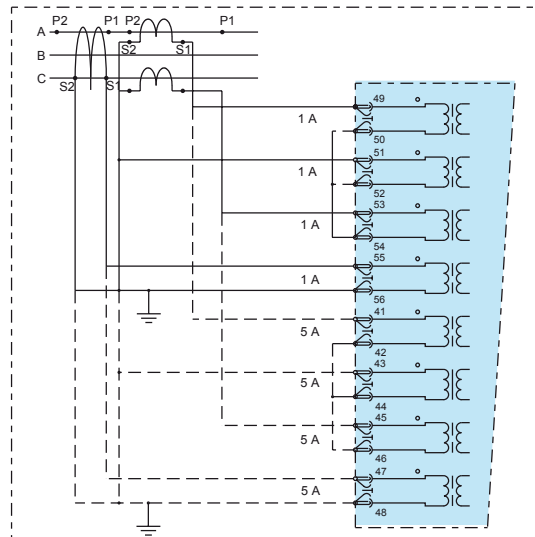

MiCOM P122 / P123 / P127

Base Unit

(cont.)

P127: Advice for external connections

Scheme representing micom relay off

DM101194EN

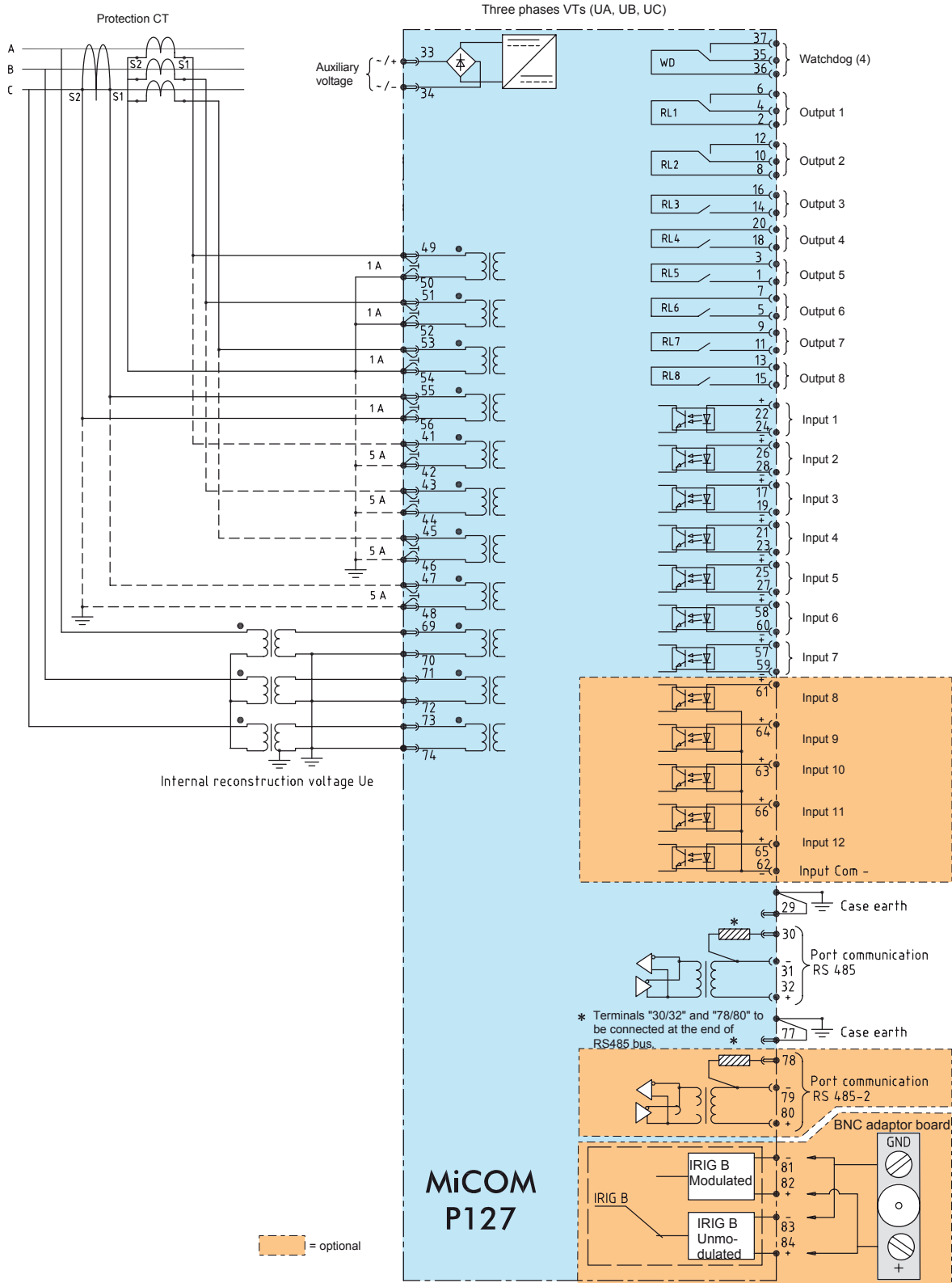

3



The MiCOM P220 / P225 relays are designed to secure industrial processes. Their wide range of features provides complete protection for all types of application, and a rapid and selective clearance of motor faults.

3

Customer benefits



- Provide comprehensive protection functions for a wide range of applications
- Optimize the installation cost
- Improve monitoring conditions
- Reduce the need of documents and trainings
- Save time on day-to-day use

The MiCOM P22x protection relay range is designed for motor protection applications. A complete set of protection functions is performed on the measurement of current, voltage* and temperature. In addition to these basic functions, the relay carries out a large number of other functions that enable it to protect and run the motor more effectively.

The reliability of the system is further enhanced via checks on bus voltage prior to start-up* during reacceleration, supervision of trip-circuit wiring continuity and protection against circuit-breaker failure.

The MiCOM P22x protection relay range is particularly adapted to oil refinery, chemical plant, metallurgy, glass and cement manufacturing, paper mills, electrical and mechanical engineering, food production, mining etc. It is also suitable for water treatment and in pumping stations as well as in steam power plants.

On top of that high inertia loads and anti-backspin protection ensures that the rotor stops before the motor can be re-started.

For motors whose current supply contains a considerable degree of distortion, the relay provides a true RMS base thermal image allowing efficient protection against overload phenomena due to the presence of harmonic components.

The addition of power measurement* and energy metering*, and the presence of analogue outputs (current loop) make the MiCOM P22x protection relay range a highly competitive and effective equipment in terms of protection.

* P225 only

Application

The MiCOM P22x protection relay range performs and offers numerous functions in a compact design:

- Protection
- Monitoring
- Diagnosis
- Fault analysis tools
- Aid to maintenance

Compact and “Plug and play”, the P22x protection relay range supplies essential functions for industry applications, where the following requirements must be achieved:

- Small and medium motors
- High inertia
- Easy to use
- Universal auxiliary supply
- Low cost

Main functions

Protection functions are autonomous and can be individually configured or disabled to suit a particular application.

Inputs and Outputs Ratings

Analogue current inputs

Phase currents In	1 and 5 A	
Earth current Ion	1 and 5 A	
Frequency	Range	45 to 65 Hz
	Nominal	50/60 Hz
Burdens	Phase current inputs	<ul style="list-style-type: none"> ■ < 0.3 VA @ In (5A) ■ < 0,025 VA @ In (1A)
	Earth current input	<ul style="list-style-type: none"> ■ < 0.01 VA @ 0.1Ion (5A) ■ < 0,004 VA @ 0,1 Ion (1A)
Thermal withstand of both phase and earth current inputs		■ 100 In - 1 s
		■ 40 In - 2 s
		■ 4 In - continuous

Analogue voltage inputs (P225 only)

Frequency	Range	■ Phase A - Phase C voltage input : Vn	■ 57-130 Volt (range A)
		■ or 3-phase voltage inputs (optional)	■ 220-480 Volt (range B)
	Nominal	50/60 Hz	
Burden	< 0,1 VA @ Vn		
Thermal withstand	Range A	■ 260 V - continuous	
		■ 300 V - 10 s	
	Range B	■ 960 V - continuous	
		■ 1300 V - 10 s	

Logic inputs

Type	Independent optical isolated
Number	<ul style="list-style-type: none"> ■ Standard: 6 (5 programmable, 1 fixed) ■ Optional: 5 additional digital inputs
Burden	< 10 mA for each input
Recognition time	< 5 ms

Supply ratings

Relay auxiliary power supply			Logic Inputs				
Ordering Code	Nominal voltage range Vx	Operating voltage range	Nominal Voltage range	Minimal polarisation voltage	Maximum polarisation current	Holding current after 2 ms	Maximum continuous withstand
Z	<ul style="list-style-type: none"> ■ 24 – 250 Vdc ■ 48 – 240 Vac 	<ul style="list-style-type: none"> ■ 19.2 – 300 Vdc ■ 38.2 – 264 Vac 	<ul style="list-style-type: none"> ■ 24 – 250 Vdc ■ 24 – 240 Vac 	<ul style="list-style-type: none"> ■ 19,2 Vdc ■ 19.2 Vac 	35 mA	2.3 mA	<ul style="list-style-type: none"> ■ 300 Vdc ■ 264 Vac



Ratings

(cont.)

Output relay**Contact rating**

Contact relay	Dry contact Ag Ni
Make current	Max. 30A and carry for 3s
Carry capacity	5A continuous
Rated Voltage	250Vac

Breaking characteristic

Breaking capacity AC	■ 1500 VA resistive	
	■ 1500 VA inductive (P.F. = 0.5)	
	■ 220 Vac, 5A (cos φ = 0.6)	
Breaking capacity DC	■ 135 Vdc, 0.3A (L/R = 30 ms)	
	■ 250 Vdc, 50W resistive or 25W inductive (L/R = 40ms)	
Operation time	<7ms	
Operation time	<7ms	
Durability	Loaded contact	10000 operation minimum
	Unloaded contact	100000 operation minimum

Optional 6 or 10 RTD inputs

RTD type	Pt100, Ni100, Ni120, Cu10
Connection type	3 wires + 1 shielding
Maximum load	■ 25 Ω (Pt100, Ni100, Ni120)
	■ 2,5 Ω (Cu10)
Insulation	2 kV, active source mode

Accuracy

Protection thresholds	$\pm 2\%$	
Time delays	$\pm 2\%$ with a minimum of 40ms	
Measurements	Current	Typical $\pm 0,2\%$ @ I_n
	Voltage	Typical $\pm 0,2\%$ @ V_n
	Power	Typical $\pm 1\%$ @ P_n
	Temperature	$\pm 2\text{ }^\circ\text{C}$
Pass band for measurements of true RMS values	500Hz	

CT & VT data

Phase CTs primary	1 to 3000 by steps of 1
Earth CT primary	1 to 3000 by steps of 1
Phase CTs secondary	1 or 5
Earth CT secondary	1 or 5
Recommended phase CTs	5P10 - 5VA (typical)
Recommended earth CT	Residual connection or core balanced CT (preferred in isolated neutral systems)
VT primary (P225 only)	1 to 20 000 V by steps of 1 V
VT secondary (P225 only)	Range A 57 to 130 V by steps of 0,1 V

Functional overview

(Description of ANSI code nos., see Protection Functions Table)

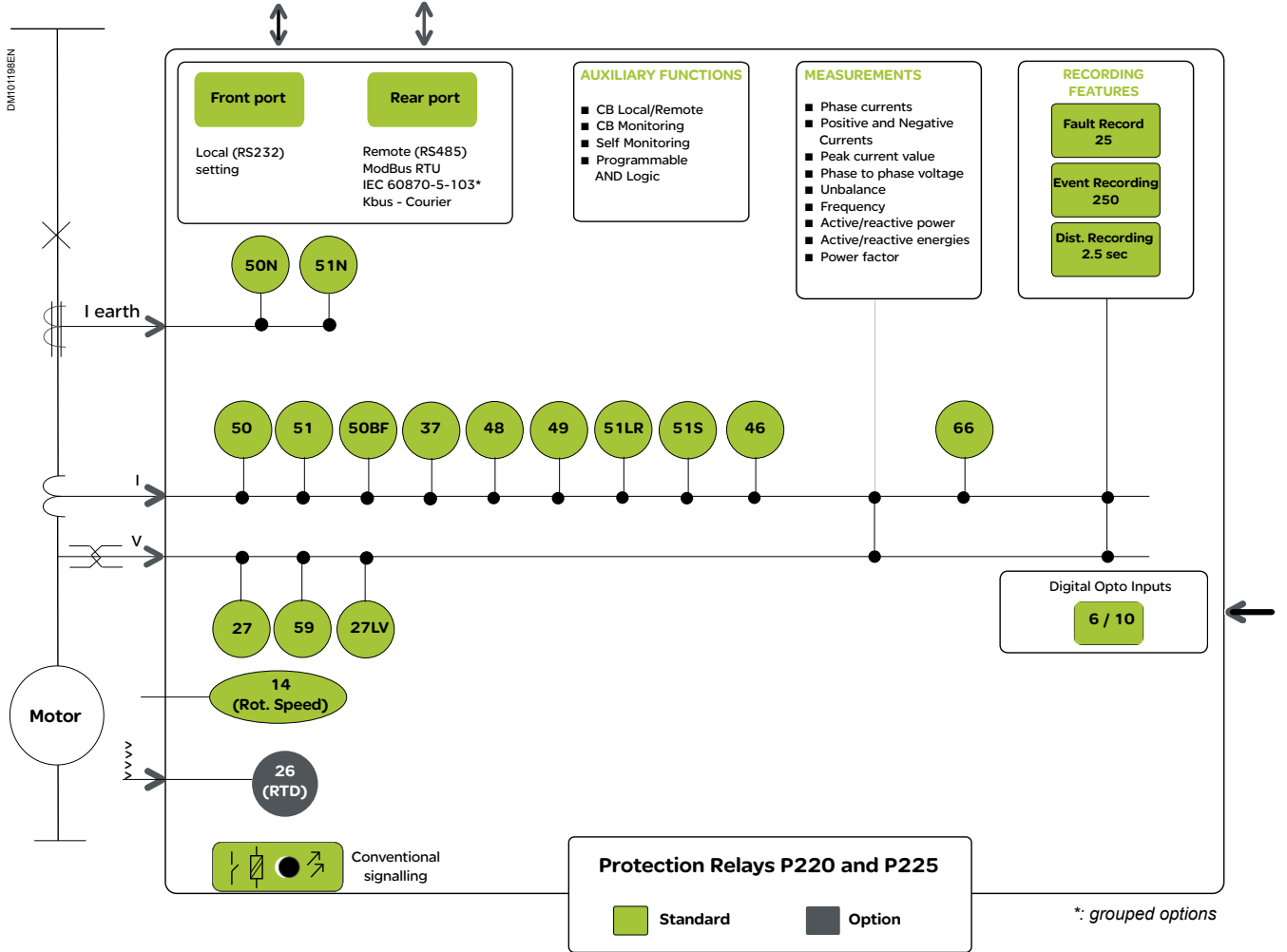

ANSI codes	Protection functions	P220	P225
12/14	Speed switch inputs	■	■
27/59	Phase under/over voltage (AND & OR mode)		■
27LV	Re-acceleration autorisation		■
37	Undercurrent / Loss of load	■	■
38/49T	Optional RTD	6	10
46	Negative phase sequence overcurrent	■	■
48/ 51LR	Start / Stalled Protection / Motor Re-Acceleration	■	■
49	Thermal overload	■	■
50BF	Circuit breaker failure		■
50 / 51	3-Phase overcurrent	■	■
50N / 51N	Earth overcurrent / Sensitive earth fault	■	■
51S	Locked Rotor during Start-up	■	■
66	Number of Starts Limitation	■	■
86	Output relay latching	■	■
CBF	Circuit breaker fail protection	■	■
TCS	Trip Circuit Supervision	■	■

Control and Monitoring	P220	P225
Emergency Restart	■	■
Selective relay scheme logic	■	■
Boolean logic equation	8	8
AND / OR and NOT gates	■	■
CB Control & Monitoring (Local/ remote)	■	■
Setting Groups	2	2
Auxiliary timers	10	10
Measurements and Records		
Measurements	■	■
Power and Energy Measurements		■
Hours Run	■	■
CB Operations	■	■
Disturbance Records up to number x 2.5 sec (backed-up)	5	5
Fault Records (backed-up)	25	25
Event Logging (backed-up)	250	250
Communication		
Front port (RS232)	■	■
Rear port (RS485)	■	■
Rear Port Communication Protocol		
Modbus RTU	■	■
IEC 60870-5-103	■	■
Hardware		
Logic inputs	6	6
Outputs relays	6	6
1/5 dual rated AC Current inputs (settable)	4	4
57....130 V AC Voltage inputs		1/3

3

Three-Phase Overcurrent (50/51)

Three independent stages are available in P220/P225 for phase fault protection. For the first and second stage the user may independently select definite time delay (DTC) or inverse time delay (IDMT) with different type of curves (IEC, IEEE/ANSI, RI). The third stage is definite time only. Each stage and related time delay can be programmed to provide maximum selectivity. The IDMT stages have reset definite or IDMT timer to reduce clearance times when intermittent faults occur.

Earth Fault (50N/51N)

Two elements are available. Each threshold has instantaneous and delayed signal at its disposal. The adjustment range for earth current threshold varies from 0.002 to 1 len, allowing maximum sensitivity for earth fault detection. The relay's earth current input can be wired to a core balanced CT or to the summation of the three-phase CTs.

CB Failure (50BF)

The CB failure on fault will be detected very quickly by the P220/P225 relays, which will then either send a new local tripping signal or act directly on the immediately upstream CB.

By speeding up the time taken to clear the fault in the case of CB failure, the P220/P225 relays help maintain the stability of the network and the reliability of the protection system.

**Limitation of the Number of Starts,
Time between Starts (66)**

The number of motor start-ups can be limited. The P22x relay can discriminate between a warm and a cold motor, making it possible to optimise the number of start-ups allocated to a particular motor over a given period of time. Setting a minimum delay between two start-ups avoids exposing the motor and its start-up system to over-large resultant stresses.

Loss of Load (37)

Loss of load, caused by shaft rupture or the unpriming of a pump, is detected by a timed minimum phase under current threshold. This function can be deactivated during the start-up phase so that the motor can gradually increase its load.

Unbalance, Loss of Phase and Single Phasing (46)

Two overcurrent elements based on the negative sequence component of current are available. One is associated with an IDMT characteristic, while the other has a definite time characteristic. The two elements make it possible to differentiate between a short or low amplitude unbalance and a more marked phenomenon such as loss of phase or single phasing.

Thermal Overload (38/49T) - True RMS Base

The thermal image of the MiCOM P22x relay allows for simultaneous protection of the rotor and stator windings of the motor, whatever the operating conditions of the machine, under and overload operating conditions, during start-up, with rotor locked or with the motor off.

Classic I²t thermal images afford protection to stator windings but do not take account of overheating in the rotor during a current unbalance. Similarly, the presence of harmonic current components causes additional overheating of the stator windings. In order to take this overheating properly into account, the P22x relay separates the negative sequence current and reconstitutes it with the true RMS value of the stator currents absorbed by the motor. The result is better protection against overloads and hence a marked decrease in the risk of motor damage. An alarm threshold, tripping threshold and thermal threshold, beyond which the motor cannot be re-started, are available.

As an option, RTDs can be connected to the MiCOM P220/P225 relays to monitor the motor's temperature. For each of the RTD channels, two temperature thresholds with individual time-delay settings are available. It is therefore possible to monitor stator windings separately, as well as the spin bearings of the motor and the load involved.

**P225: Undervoltage (27) / Overvoltage (59) / Re-acceleration
Authorisation (27 LV) / Auto Restart**

If supply voltage drops or the supply is lost completely, a phase-to-phase under voltage threshold causes the motor to stop. This function on P225 relays can be selectively put into or out of operation during the motor start-up phase. An over-voltage threshold (P225 only) protects against over-voltage and also give warning of ageing insulators.

The relays can detect voltage sag via the voltage input (P225 only) or by using an external U/V device and a logical input of the relay (P220/P225). Depending on the duration of the voltage sag, the P220/P225 relays can authorise a re-acceleration of the motor when voltage is restored or, on the other hand, stop the motor to allow the motors most critical to the process to re-accelerate. P225 relay can also auto re-start the motor if the voltage is restored within a set time after it has been stopped due to voltage sag condition or a sequential re-start to be programmed to allow load restoration in a controlled manner.

Latching of Output Relays (86)

The trip order can be maintained to avoid the risk of re-starting on an electrical, mechanical or thermal fault.

Excessive Start Time (48) / Locked Rotor while Running or at Start-up (51LR)

Whether the motor is unloaded or coupled to a heavy load, this function monitors the duration of the motor start-up phase. The choice of the motor's start-up detection criteria makes it possible to use this function, whatever the motor's start-up mode: eg, direct-on-line, star-delta, auto-transformer, resistor insertion, etc. During normal motor operation, an overcurrent threshold detects rotor stalling.

Locked Rotor while Running or at Start-up (51S)

During motor start-up, a locked rotor is detected with the help of a speed switch input on P220/P225 relays.

Anti-backspin

If a motor with a high inertia load, for example a fan, is stopped, the shaft continues to rotate for some time before the rotor stops completely. If the motor is switched back on while the rotor is still turning, a condition akin to a false coupling may occur, causing mechanical damage such as broken fan blades. The risk of such problems can be eliminated by setting a minimum time-lapse between stopping the motor and re-starting it.

Presence of Bus Voltage Prior to Start-up

Prior to starting the motor, the P225 relay checks that voltage levels are sufficiently high before authorising the start-up sequence.

Emergency Start-up

When required by safety conditions or by the process, a logical input of the P22x relay can be used to allow motor start-up. All start-up restrictions will then be inhibited and the thermal image function will be disabled.

Overspeed (12)

Detection of machine overspeed, based on the speed calculated by pulse-counting, to detect synchronous generator racing due to loss of synchronism, or for process monitoring, for example.

Underspeed (14)

Machine speed monitoring based on the speed calculated by pulse-counting:

- detection of machine underspeed after starting, for process monitoring, for example
- zero speed data for detection of locked rotor upon starting.

Control functions

Independent Protection Setting Groups

By virtue of its two setting groups, the MiCOM P22x relay allows for the protection of dual-speed motors as well as motors operating under environmental or operational conditions, which are not constant over time. A change of setting group can be useful following a change in source impedance. The result is improved selectivity.

Boolean logic equation

MiCOM P22x can achieve up to 4 AND logical gates linked to time delays, by combining internal and external information with the protection relay. The user can also create OR gates by individually programming each output relay. The logical gates help make economies on external relaying and make the relay interactive with the process.

Current Transformer Supervision (CTS)

Current transformer supervision is provided to detect loss of phase CT based on zero sequence current occurrence combined with zero sequence voltage disappearance.

CB Monitoring

Preventive CB maintenance is provided by monitoring summated contact breaking duty, the number of switching operations and the opening time. If a pre-set threshold is exceeded, the P220/P225 relay will generate an alarm signal.

External Trips

The P22x relay accepts external binary signals, which can be used to give a trip or alarm signal, or which may simply be treated as binary information to be passed on through the relay to a remote control system.

Shape of Start-up Current and Voltage

The MiCOM P22x relay records the envelope of both start-up current and voltage signals with a resolution of one sample for every 5 periods. This recording can be uploaded to a PC via the communication network or via the RS232 port on the front plate. It is very helpful to be able to visualise these curves during commissioning and this function of the MiCOM P22x avoids the need for a plotter.

Motor Start Curves

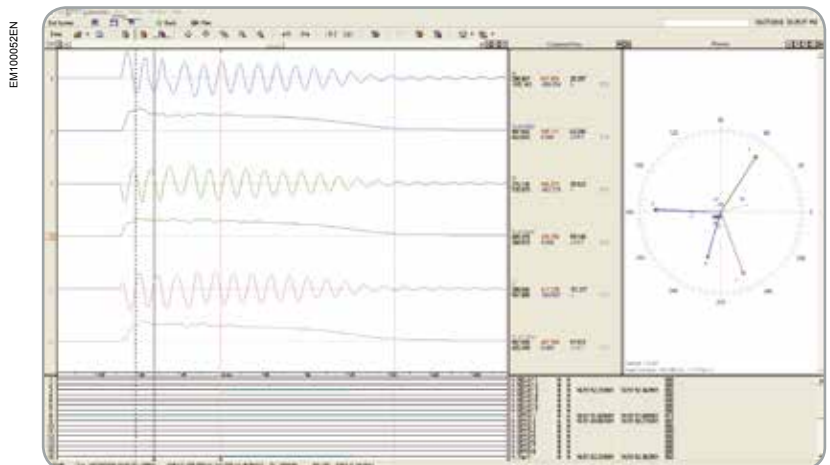

Analogue Outputs

Two optional analogue outputs are available. Some information and measurements such as power (P225), energy (P225) and temperature values, etc., can be fed through a current loop to a PLC.

Trip Cause Statistics

The MiCOM P22x relay provides the user with trip statistics for every protection function. The user can thus keep track of the number of trips, which have taken place as well as their origin.

(cont.)

Measurements and recording facilities

Measurements

The MiCOM P22x relay constantly measures a large amount of electrical data, such as:

- Phase current magnitude in true RMS value: IA, IB, IC
- Neutral current magnitude in true RMS value: IN
- Positive sequence current I1
- Negative sequence current I2
- Zero sequence current Io
- Unbalance ratio I1/I2
- Frequency
- Peak current value
- Phase-to-phase voltage in true RMS value (P225 only)
- Active and reactive power W and VAR (P225 only)
- Active and reactive energies Wh and VARh (P225 only)
- Power factor (P225 only)

To provide the user with more accurate information on the motor's status and availability, the P22x relay keeps track of:

- Thermal status of the motor
- Load value as a % of full load current
- Time to thermal trip
- Temperature of each RTD (optional)
- Hottest RTD (optional)
- Authorised start number
- Time before another start-up authorisation
- Last start current magnitude
- Last start time value
- Number of starts and emergency starts
- Total motor running hours

Event Records

The last 250 status changes are recorded in a non-volatile memory. This covers all status changes to logic inputs and outputs, modifications to one or more parameters, alarm signals or the operation of one of the output contacts. Events are logged every 1 ms.

Fault Records

The P22x relay records the last 25 faults. The information provided in the fault record includes:

- Fault number
- Date and time
- Active setting group
- Faulty phase or phases
- Function that gave the trip
- Magnitude of the value that gave rise to the trip command
- Values of the phases and earth currents and voltage (P225 only)

Disturbance Records

5 disturbance records, of 2.5 seconds each, can be stored. Disturbance record can be uploaded via the communication network (RS485) or locally (RS232)

MiCOM P220 / P225

Control & Monitoring

(cont.)

Dedicated and Programmable LEDs

4 LEDs show the relay's status (Trip, Alarm, Warning and Healthy). MiCOM P22x relay offers free programming of 4 LEDs. Each LED can be assigned to one or more functions or logic states and then limit the need for external signal lights. Each LED can also be assigned to any one of the 6 logical inputs as well as the internal Auto Re-start signal.

Local and Remote Communication

The MiCOM P220/P225 relays are equipped with a RS485 port on its rear plate, which enables them to communicate via MODBUS™, Courier or IEC 60870-5-103. It is thus possible to transmit adjustment values, measurement data, alarm signals and all other recordings to the Substation Control System or to a SCADA. Communication parameters can be adjusted by the operator via the user interface. Communication failure does not affect MiCOM relays' protective functions.

Software support

MiCOM S1 Studio software makes it possible to pre-set all MiCOM P22x relay parameters from a PC. The relay is then accessed via the RS232 port on the front panel.

MiCOM S1 Studio software is fully compatible with Windows™ (95, 98, NT, 2000, XP), and can download relay settings, pull up current relay settings and upload measurement values, diagnostic data, fault records, disturbance records, start-up current and voltage shapes and event logging data.

Protection functions setting ranges

Functions	Setting range		
	min.	max.	Steps
[27] Undervoltage protection (P225 only)			
Voltage threshold V< Range A	5 V	130 V	0,1 V
Time-delay tV<	0 s	600 s	0,01 s
V< inhibition during start-up	Yes/No		
Hysteresis	105 %		
[37] Under current (Loss of load) protection			
Current threshold I<	0,1 I _n	1 I _n	0,01 I _n
Time-delay tI<	0,2 s	100 s	0,1 s
Inhibition time at start-up T _{inhib}	0,05 s	300 s	0,1 s
Hysteresis	105%		
[46] Unbalance protection			
Negative sequence current threshold I _{2>}	0,04 I _n	0,8 I _n	0,01 I _n
Time-delay tI _{2>}	0 s	200 s	0,01 s
Negative sequence current threshold I _{2>>}	0,04 I _n	0,8 I _n	0,01 I _n
IDMT time-delay	t = TMS x 1,2/(I ₂ /I _n)		
Time Multiplier setting TMS I _{2>>}	0,2	2	0,001
Hysteresis	95%		
[49] Thermal replica			
Thermal current threshold I _{θ >}	0.2 I _n	1.5 I _n	0.01 I _n
Negative sequence current recognition factor K _e	0	10	1
Overload time-constant T _{e1}	1 min	180 min	1 min
Start-up time-constant T _{e2}	1 min	360 min	1 min
Cooling time-constant T _r	1min	999 min	1 min
Trip thermal threshold	Set to 100%		
Thermal alarm threshold	20%	100%	1%
Thermal trip & alarm thresholds hysteresis	97%		
Start-up inhibition	20%	100%	1%
[50/51] Short-circuit protection			
Current threshold I>	0.1 I _n	25 I _n	0.05 I _n
Delay type	DT, IDMT or RI		
Time delay tI> (DMT)	0 s	150 s	0.01 s
Reset time tReset	0 to 600 s by steps of 0.01 s		
Interlock with I>> & I>>> (IDMT)	Yes / No		
Reverse Time Multiplier Setting (IDMT reset delay type)	0.025	1.5	0.01
K multiplier (RI curve)	0.1	10	0.001
Current threshold I>>	0.5 I _n	40 I _n	0.05 I _n
Delay type	DT, IDMT or RI		
Time delay tI>> (DMT)	0 s	150 s	0.01 s
Reverse Time Multiplier Setting (IDMT reset delay type)	0.025	1.5	0.01
K multiplier (RI curve)	0.1	10	0.001
Current Time delay tI>>>	0 s	150 s	0.01 s
threshold I>>>	0.5 I _n	40 I _n	0.05 I _n
Time delay tI>>> (DMT)	0 s	150 s	0.01 s
Operating time	< 40 m		
Drop-off time	< 30 ms		
Hysteresis	95 %		

Setting ranges

(cont.)

Functions	Setting range		
	min.	max.	Steps
[50/51N] Earth fault protection			
Current threshold $I_{o>}$, $I_{o>>}$	0.002 I_{on}	1 I_{on}	0.001 I_{on}
Time-delays $t_{lo>}$, $t_{lo>>}$	0 s	100 s	0.01 s
Operating time	< 40 ms		
Drop-off time	30 ms		
Hysteresis	95%		
[51LR/50S] Locked rotor protection			
Current threshold I_{stall}	0.5 I_n	5 I_n	0.01 I_n
Hysteresis	95%		
Time-delay t_{stall}	0.1 s	60 s	0.1 s
Locked rotor at start-up detection	No/Input/Power Factor		
Power factor	0.01	1	0.01
[59] Overvoltage protection (P225 only)			
Voltage threshold $V_{>}$	Range A	5 V	260 V
	Range B	20 V	960 V
Time-delay $t_{V>}$	0 s	600 s	0.01 s
Hysteresis	95 %		
Too long start-up protection (Start-Up criteria)			
Start-up detection criteria	(closing 52) or (closing 52 + current threshold) optional		
Current threshold I_{UTIL}	0.5 I_n	5 I_n	0.01 I_n
Time-delay t_{Istart}	1s	200 s	1 s
Optional 6 (P220) or 10 (P225) RTD inputs			
Thresholds	0 °C	200 °C	1 °C
Time delays	0 s	100 s	0.1 s
Thermal image influence	Yes/No		

Automation functions setting ranges

Functions	Setting range			
	min.	max.	Steps	
[66] Limitation of the number of start-ups				
Reference period Trefrence	10 min	120 min	5 min	
Number of cold starts	1 t	5	1	
Number of hot starts	0	5	1	
Restart inhibition time TInterdiction	1 min	20 min	1 min	
Time between 2 start-ups				
Inhibition time Tbetw 2 start	1 min	120 min	1 min	
Anti-backspin protection				
Restart prevention time tABS	1 s	7200 s	1 s	
Re-acceleration authorization (P225 only)				
Voltage dip detection	Range A	37 V	98 V	0.2 V
	Range B	143 V	360 V	0.2 V
Voltage restoration detection	Range A	45 V	117 V	0.2 V
	Range B	176 V	32 V	0.2 V
Voltage collapse duration Treacc	0.1 s	5 s	0.01 s	
Auto Re-Start delay treacc long	OFF	60 s	1 s	
Auto Re-Start restoration delay treacc shed	OFF	99 min	1 min	
Presence of bus voltage prior to start-up (P225 only)				
Voltage threshold	Range A	5 V	130 V	0.1 V
	Range B	20 V	480 V	0.5 V
Hysteresis		105 %		
CB failure				
Current threshold I< BF		10 % In	100% In	10% In
Time-delay tBF		0.03 s	10 s	0.01 s
Trip circuit supervision				
Time-delay tSUP		0.1 s	10 s	0.01 s
Auxiliary timers				
Logic inputs with alarm message on occurrence		tAux1 to tAux10		
Timers tAux1 to tAux10		0 s	200 s	0.01s
Boolean logic equation				
<ul style="list-style-type: none"> ■ 8 independants equations are available ■ Each one can used a maximum of 16 operands among all start and trip signal ■ Each one can use NOT, OR, AND, OR NOT, AND NOT logical gates 				
t operate		0 s	600s	0.01s
t Reset		0 s	600s	0.01s
Latching of output relays				
Trip relay (RL1)		Configurable for each trip order		
Auxiliary relays (RL2, RL3, RL4 and RL5)		Configurable for each auxiliary relay		
CB control and monitoring				
Close command hold		0.2 s	5 s	0.05 s
Open command hold		0.2 s	5 s	0.05 s
Number of operations alarm		0 operations	50 000 operations	1
Summated contact breaking duty		106	4 000.106	106
Adjustment of the exponent «n»		1 or 2		
Opening time alarm		0.05 s	1 s	0.05 s

(cont.)

Recording functions setting ranges

Functions	Setting range		
	min.	max.	Steps
Event recorder			
Capacity	250 events		
Time-tag	to 1 millisecond		
Triggers	<ul style="list-style-type: none"> ■ Any protection alarm & threshold ■ Any logic input change of state ■ Self test events ■ Any setting change 		
Fault recorder			
Capacity	25 records		
Time-tag	to 1 millisecond		
Triggers	<ul style="list-style-type: none"> ■ Any trip order (RL1 operation) 		
Data	<ul style="list-style-type: none"> ■ Fault record number ■ Fault date & hour ■ Active setting group ■ Faulty phase(s) ■ Fault type, protection threshold ■ Fault current/voltage magnitude ■ Phase A, B, C and earth current magnitudes ■ Phase A-Phase C voltage magnitude ■ VAB, VBC, VCA ("3 voltage inputs" option) 		
Oscillography			
Capacity	5 records		
Duration of each record	2,5 s		
Sampling rate	32 samples per frequency cycle		
Pre-time setting	0,1 s	2,5 s	0,1 s
Post-time setting	0,1 s	2,5 s	0,1 s
Triggers	<ul style="list-style-type: none"> ■ Any protection threshold overreach or any trip order (RL1 relay operation) ■ Logic input ■ Remote command 		
Data	<ul style="list-style-type: none"> ■ 4 analogue current channels (3 ϕ + N) ■ Logic input and output states ■ Frequency value ■ 1 (or 3) analogue voltage channel ("3 voltage inputs" option) 		
Start-up current and voltage envelope record			
Capacity	1 record		
Maximum duration	200 s		
Sampling rate	1 sample each 5 frequency cycles		
Data	Current	True RMS value, maximum value of one of the 3 phase currents	
	Voltage (P225 only)	True RMS value	



3

Presentation

User-Machine Interface (HMI) - Front Plate and Menus

All the relay's parameters, ie., protection functions, logic controls, communication, LEDs, inputs and outputs, can be programmed and modified by push-buttons located on the front panel. An alphanumeric, backlit, 32-character LCD screen displays all the relay's data (settings, measurements, etc.).

The menus are designed so that the user can move around them easily, without confusion. The user will soon be at ease with the Human-Machine Interface.

Working language

The following languages can be settable in most of the relays:

- French, English, Spanish, Portuguese, Turkish, Polish, Russian, Chinese, Dutch, German, Italian, Czech, Hungarian and Greek.

Wiring

The individual equipment is delivered with sufficient M4 screws and washers to connect the relay via insulated crimp/pressure ring terminals. The maximum number of insulated crimp/pressure ring terminations, per terminal block terminal shall be two.

Terminals	Wire size
Push-on connector: 4.8 x 0.8mm	0.75 - 1.5 mm ² /22AWG - 16AWG
M4 90° Ring Tongue terminal	0.25 - 1.65 mm ² 22AWG - 16AWG
M4 90° Ring Tongue terminal	1.04 - 2.63 mm ² 16AWG - 14AWG)

NOTE: Pressure/crimp push-on or ring terminals may be used for communication circuit connections. Only pressure/crimp ring terminals shall be used for connections to other circuits

Communication

Communication software: MiCOM S1 Studio.

Type Port	Physical Link	Connectors	Data Rate	Protocol
RS485 Rear port	Screened twister pair	Screws or snap-on	■ 300 to 38400 baud (programmable)	■ ModBus RTU ■ IEC60870-5-103
RS232 Front port	Screened twister pair	PC: 9 pin D-type male connector P220/225: Sub-D 9 pin female connector	■ 300 to 38400 baud (programmable)	■ ModBus RTU

	ModBus	IEC 60870-5-103	Front comms.
Transmission mode	Synchronous	Synchronous	
Interface	RS 485, 2 wires + shielding	RS 485, 2 wires + shielding	RS232 / Protocol: MODBUS™ RTU
Data rate	300 to 38 400 bauds (programmable)	9600 to 19200 bauds (programmable)	19200 bauds
Relay address 1	to 255	1 to 254	
Parity	Settable	Even	Without
Comms. mode	RTU standard		<ul style="list-style-type: none"> ■ Data Bit:8 ■ Stop bit: 1
Date format	IEC format or Private format		
Connection	Multi-point (32 connections)	Multi-point (32 connections)	Sub-D 9 pin female connector
Cable	Half-duplex (screened twisted wire pair)	Half-duplex (screened twisted wire pair)	Screened twisted wire cable, no-crossed
Maximum cable length	1000 meters	1000 meters	
Connector	Connector screws or snap-on	Connector screws or snap-on	
Insulation	2 kV RMS	2 kV RMS	



Dimensions & weight

Case

The MiCOM P220/P225 relays are housed in a 4U case and suitable for either rack or flush-mounted. The relay can be withdrawn from its case with the supply voltage connected due to the presence of internal shorting links protecting the current circuits.

Dimensions P220 / P225	
■ Height	177mm
■ Width	154,2 mm (30TE)
■ Depth	247,1 mm
Weight P220 / P225	
■ Weight	approx. 4 Kg

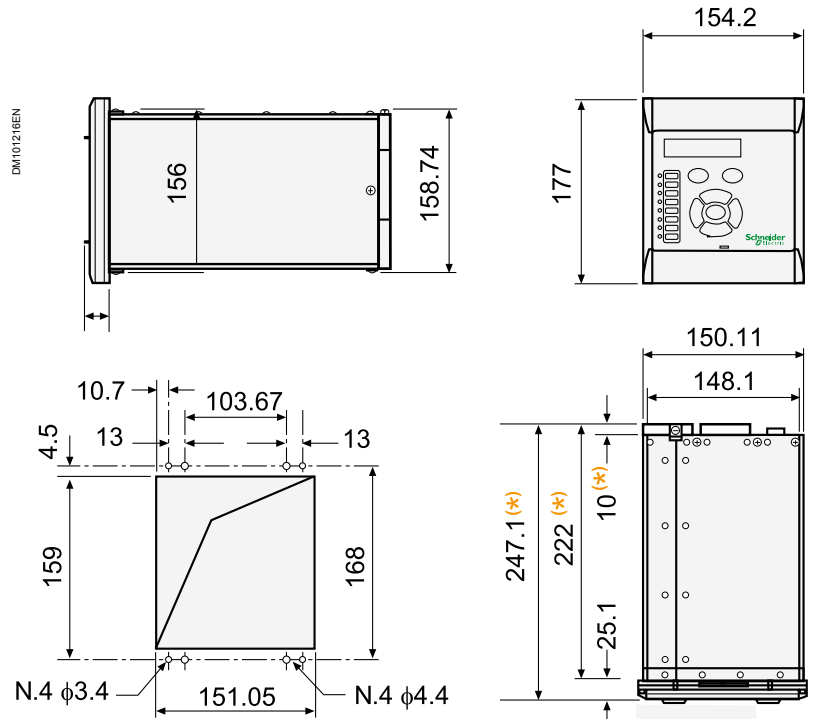

All dimensions in mm

(*) For P220/P225 with RTD option, add + 8 mm to the length

(cont.)

Front panel description

- 1 Upper flap
- 2 Backlit display device
3 x 16 characters
- 3 Trip LED
- 4 Alarm LED
- 5 Warning LED
- 6 Power LED
- 7 Programmable LEDs
- 8 2 touch-sensitive buttons to read and acknowledge alarm messages
- 9 Parameterisation and setting keypad
- 10 RS232 port
- 11 Lower flap (removed)

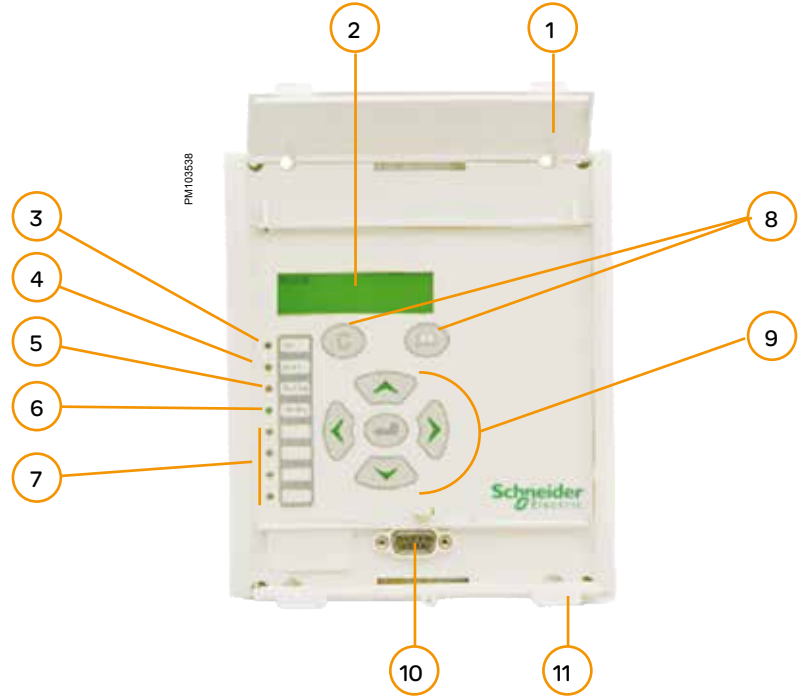

Rear panel description

- 1 Connector 1
- 2 Connector 2
- 3 OPTION P2/P3

The rear face of the MiCOM P220 / P225 relays comprises at least 2 connectors.

The relays may have (optional) :

- two green connectors dedicated to the connection of 6 temperature RTD sensors (for P220) and 10 temperature RTD (for P225)

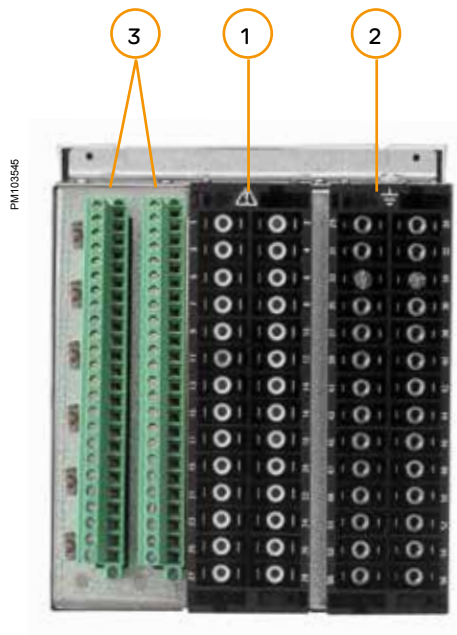

(cont.)

P220: Advice for external connections

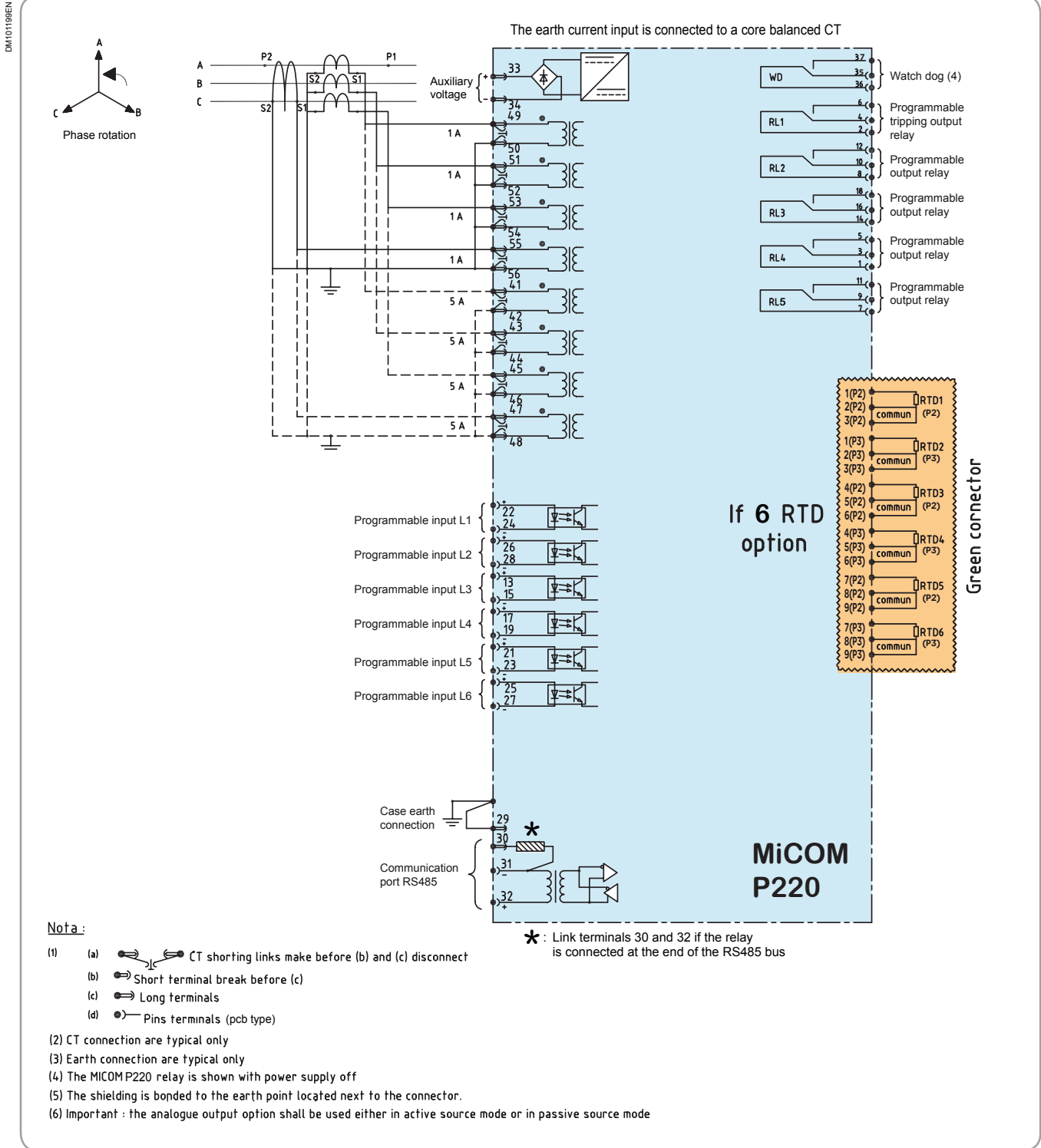

3

ADVICE for CONNECTION:

- A tightening torque of 1.3 newton is recommended for all screws fitted to the MIDOS terminal blocks.
- Functioning temperature limited to 55°C.
- For any connection use the provided kit or use cable terminals UL LISTED.
- Wiring; use copper conductors only size AWG22 to AWG10.

(cont.)

P225: Advice for external connections

DM101215EN

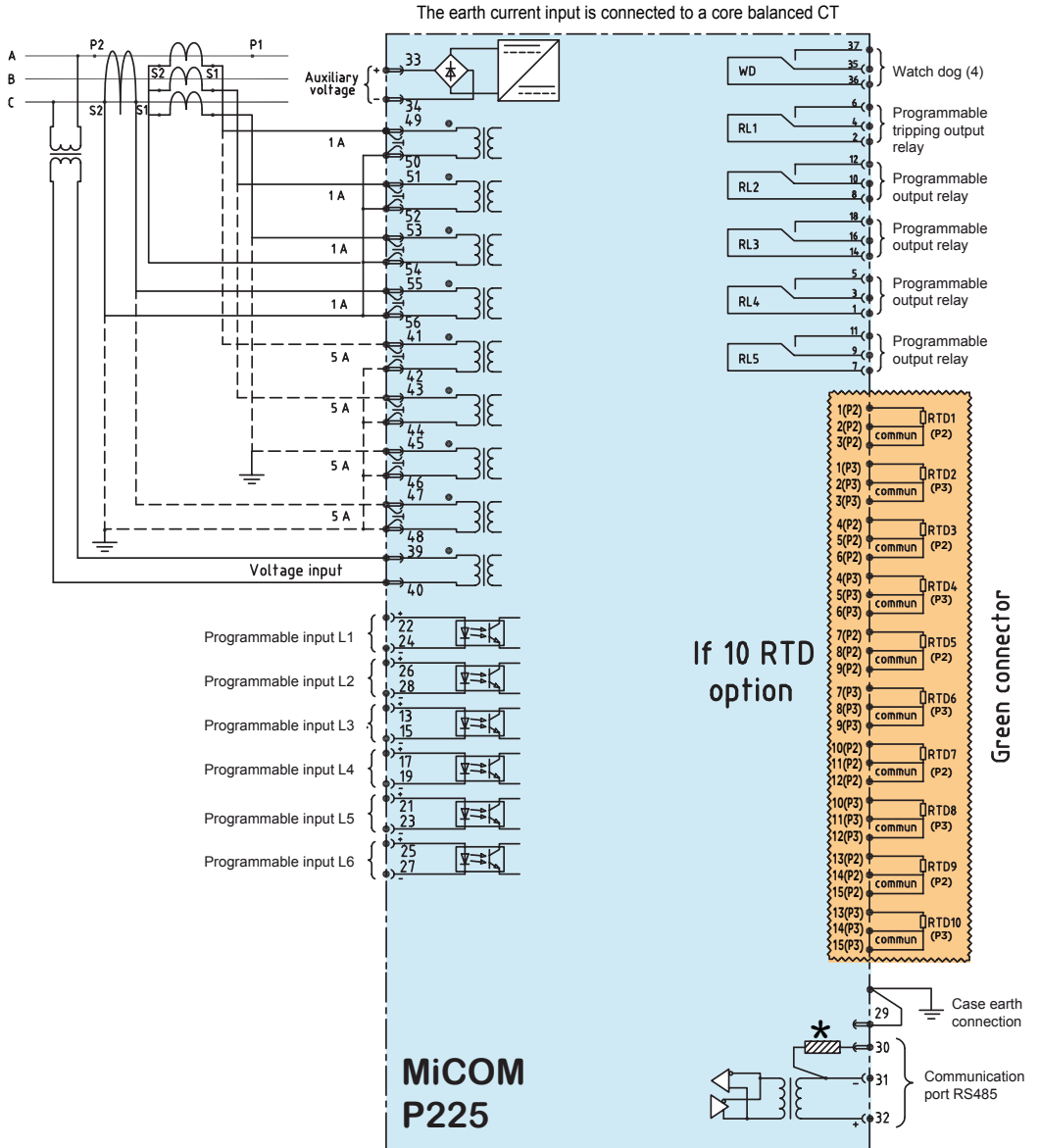
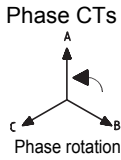

Nota :

- (1) (a) CT shorting links make before (b) and (c) disconnect
- (b) Short terminal break before (c)
- (c) Long terminals
- (d) Pins terminals (pcb type)

- (2) CT connection are typical only
- (3) Earth connection are typical only
- (4) The MiCOM P225 relay is shown with power supply off
- (5) The shielding is bonded to the earth point located next to the connector.
- (6) Important : the analogue output option shall be used either in active source mode or in passive source mode

* : Link terminals 30 and 32 if the relay is connected at the end of the RS485 bus

ADVICE for CONNECTION:

- A tightening torque of 1.3 newton is recommended for all screws fitted to the MIDOS terminal blocks.
- Functioning temperature limited to 55°C.
- For any connection use the provided kit or use cable terminals UL LISTED.
- Wiring; use copper conductors only size AWG22 to AWG10.

MiCOM P521

Fast feeder differential protection relays description

PM100820



MiCOM P521: A full suite of protection and control standard functions, which makes current differential protection available over pilot wires.

The MiCOM P521 relay provides high-speed two-ended current differential unit protection of overhead lines and underground cables in applications such as ring mains and parallel feeders. The integration of many protection functions allows application to a wide range of power systems, providing both local and remote backup protection.

Optimum phase selection is assured, as the scheme measures the currents entering and leaving the protected plant zone. Fast tripping results for an internal fault, with stability for any out-of-zone fault

The signalling interface options support metallic, direct fibre optic and multiplexed digital links. As digital communication is used, long distances between scheme ends can be achieved, and the signalling channel is monitored continuously.

Tripping uses a proven characteristic comparing differential current with through current. Phase differential elements of this type offer consistent detection of solid and resistive faults, with optimum faulted phase selection, tripping, and indication.

A full range of back-up protection is integrated. This enhances the dependability of the protection, as hot-standby elements such as overcurrent can be brought into service whenever a signalling channel outage may occur.

Customer benefits



- Highly selective unit protection
- Variety of end-to-end communications interface options
- Integrated back-up elements can run as hot standby in the event of comms channel outage
- 8 boolean logic equations
- 4 programmable inter-trip commands

Application

The MiCOM P521 current differential scheme provides a comprehensive protection package, primarily designed for unit protection of overhead and underground feeders up to and including distribution voltage levels.

The P521 is limited to three pole tripping only and is suitable for cable applications where no auto-reclosing is required.

The MiCOM P521 is supplied with a full suite of protection and control functions as standard.

Current differential protection by its nature requires few protection settings, and for most applications the factory default settings can be used - the P521 relay as supplied is ready to protect!

Transformer Applications

Figure 1 shows a protected line and transformer "unit". The P521 compensates for the vector group shift and zero sequence filtering effects of the in-zone transformer. Second harmonic restraint is used to stabilize the protection against magnetizing inrush currents.

Where transformer loads are tapped off the protected line, it is not essential to install CTs at the tap. There exists the facility to time grade the differential protection with downstream relays or fuses.

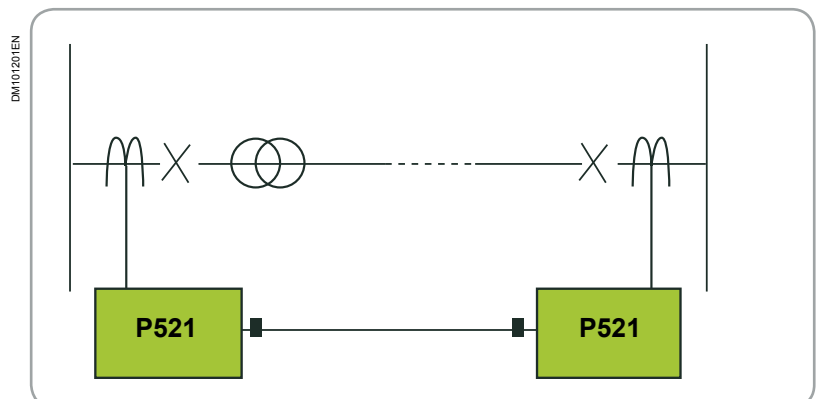

Fig.1 : P521 in-zone transformer application

Inputs and Outputs Ratings

Power Supply

Nominal auxiliary voltage Vx	24 – 60 Vdc 24 - 250 Vdc, 48 – 240 Vac
Operating range	DC: ± 20% AC: – 20%, +10%
Residual ripple	12%
Stored energy time	50 ms
Burden	3 W Standby + 0.4 W per Energized Relay + 10 mA per logic input 6 VA Standby + 0.4 VA per Energized Relay + 10 mA per logic input

Frequency

Nominal frequency	50 or 60 Hz by setting selection
Range	Nominal ± 5 Hz

Current inputs

Phase current inputs	1 and 5A by connection
Earth current inputs	1 and 5A by connection
Burden Phase Current	■ <0.025 VA (1 A) ■ <0.3 VA (5 A)
Burden Earth Current	■ <0.008 VA at 0.1□e (1 A) ■ <0.01 VA for 0.1□e (5 A)
Thermal withstand	■ 1s @ 100 x Rated Current with 400 A Maximum ■ 2s @ 40 x Rated Current ■ Continuous @ 4 x Rated Current

Output Relay

Contact rating	
Contact relay	Dry contact Ag CdO
Make current	30 Amps and carry for 3 s
Carry capacity	5 Amps continuous
Rated Voltage	250Vac
Breaking characteristic	
Breaking capacity AC	■ 135 Vdc, 0.3 Amps (L/R=30 ms) ■ 250 Vdc, 50 W resistive or 25 W inductive (L/R=40 ms) ■ 220 Vac, 5 Amps (cos φ =0.6)
Breaking capacity DC	■ 135 Vdc, 0.3A (L/R = 30 ms) ■ 250 Vdc, 50W resistive or 25W inductive (L/R=40ms)
Operation time	<7ms
Durability	
Loaded contact	>100 000 Operations
Unloaded contact	>100 000 Operations

Relay auxiliary power supply

Logic Inputs

Nominal voltage range Vx	Operating voltage range	Nominal Voltage range	Minimal polarisation voltage	Maximum polarisation current	Holding current after 2 ms	Maximum continuous withstand
■ 24 – 250 Vdc ■ 24 – 240 Vac	■ 19.2 – 300 Vdc ■ 38.4 – 264 Vac	■ 24 – 250 Vdc ■ 24 – 240 Vac	■ 19.2 Vdc ■ 19.2 Vac	35 mA	2.3 mA	■ 300 Vdc ■ 264 Vac

Functional overview

(Description of ANSI code nos., see Protection Functions Table)

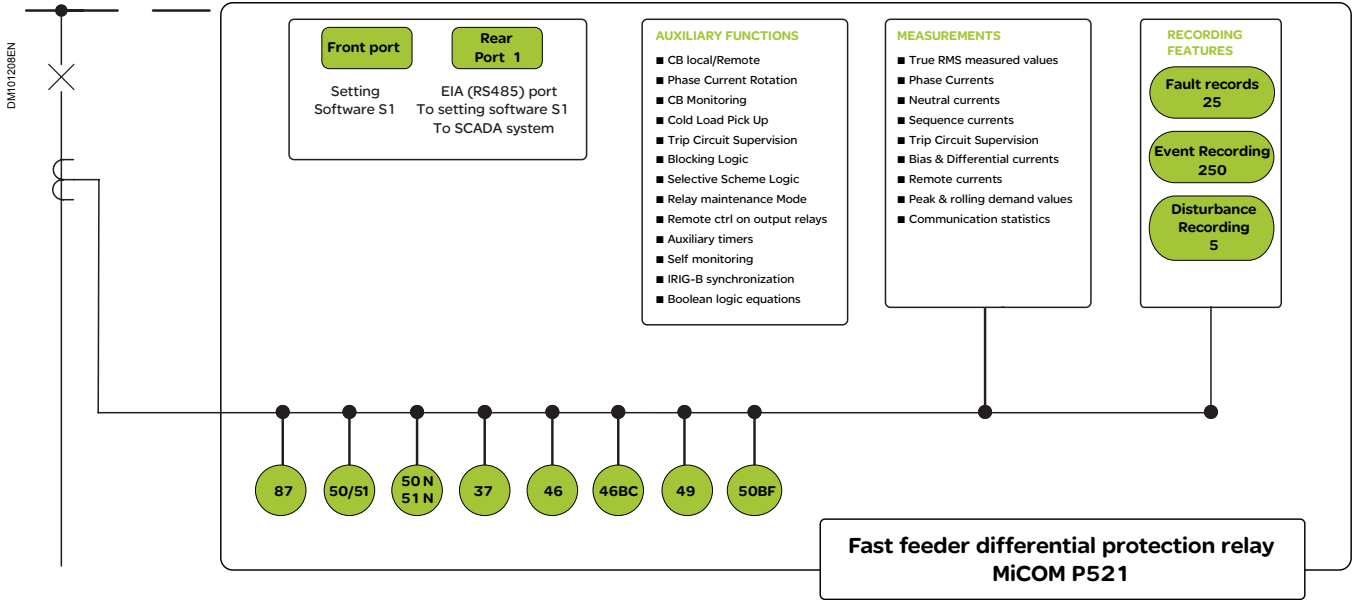

3

Protection Functions Overview		P521
37	Undercurrent detection	■
46	Negative phase sequence overcurrent	■
46BC	Broken conductor detection	■
49	Thermal overload	■
50BF	Circuit breaker failure	■
50/51	Non-directional phase overcurrent protection	■
50N/51N	Non-directional earth fault protection	■
86	Output relay latching	■
87P	Phase segregated current differential protection	■
CBF	Circuit breaker fail protection	■
CTS	Current transformer supervision	■
TCS	Trip circuit supervision	■
CLPU	Cold load pick-up protection for phase and E/F protection	■

Protection Functions Overview		P521
	Intertripping (Direct, Permissive and Current differential)	■
	Propagation delay compensation	■
	3 Pole tripping only	■
	Fibre optic or metallic signalling channels	■
	Supervision of protection signalling channel	■
	Interchangeable protection signalling interface	■
	Vector Compensation (all vector groups)	■
	Ratio Correction	■
	Inrush restraint (menu selectable)	■
	Circuit breaker control	■
	Circuit breaker monitoring	■
	Blocking logic	■
	Selective logic	■
	5 optically isolated inputs	■
	8 output relays + watchdog output relay	■
	4 fixed function LEDs and 4 programmable LEDs	■
	Front EIA(RS)232 communication port (Modbus)	■
	Rear EIA(RS)485 communication port (choice of protocol)	■
	8 Boolean logic equations	■

(cont.)

Main functions

Differential Protection (87P)

The primary protection element in the P521 relay is true, phase-segregated current differential protection. The measurement algorithm is extremely reliable, offering fast detection of internal faults, and stability for external faults.

The differential algorithm has a dual slope percentage bias restraint, as shown in Figure 2.

An internal fault will generate differential current.

3

Fig.2 : Biased Current Differential Protection

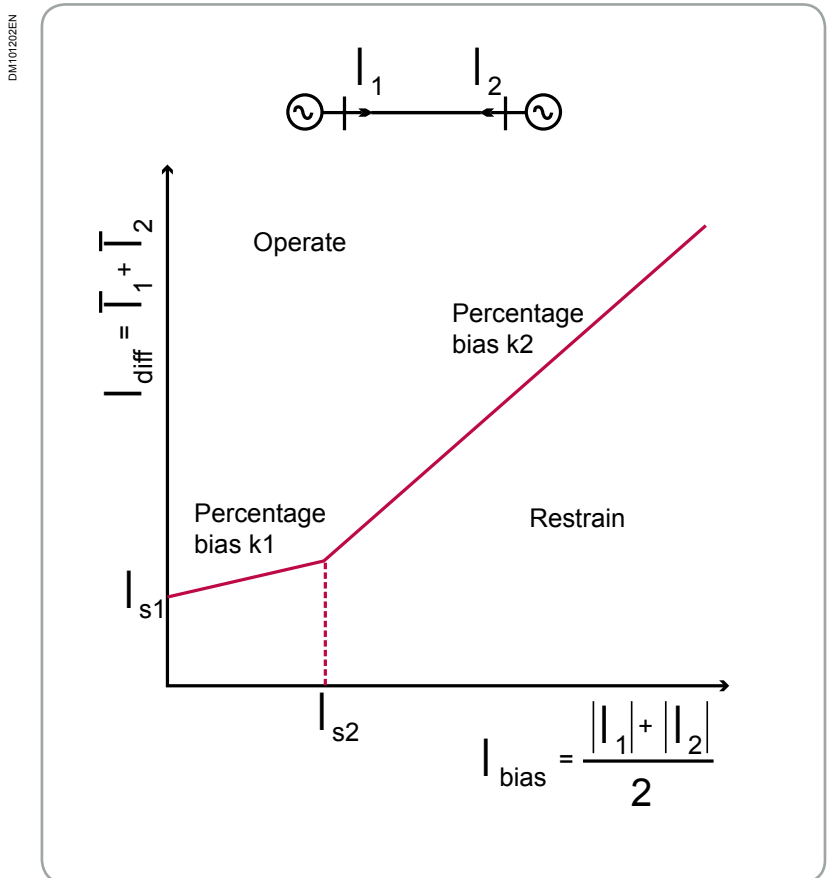

The bias current is that which merely flows through the protected unit, as a load or through-fed external fault. The initial slope (k_1) ensures sensitivity to low current faults, whereas the k_2 slope is raised to counter the effects of current transformer saturation mismatch.

When a trip is issued by the differential element, in addition to tripping the local breakers, the P521 sends a current differential intertrip signal to the remote end. This will ensure tripping of both ends of the protected line.

CT Ratio and Vector Correction

Where line CT ratios at either end of the protected feeder are different, the P521 contains a settable correction factor to compensate for the mismatch.

In applications with in-zone transformers, the P521 compensates for the vector group shift and zero sequence filtering effects of the in-zone transformer, so no external interposing CTs are required.

Inrush Restraint / Blocking

Second harmonic restraint is used to stabilize the protection against magnetizing inrush currents during transformer energisation. Alternatively, user can select the blocking mode which will block differential from tripping when the second harmonic component exceeds the setting.

MiCOM P521

Protection functions

(cont.)

Overcurrent (50/51) and Earth Fault Protection (50N/51N)

The overcurrent and earth fault protection is provided as a form of back-up protection. The P521 has four stages of overcurrent and four stages of earth fault protection. The first two stages have an IDMT or definite time (DT) characteristic.

The third and fourth stages are DT only. The overcurrent and earth fault protection can be either permanently enabled or disabled, or alternatively enabled upon failure of the differential protection communication channel. A wide range of IEC and IEEE/ANSI curves are available.

Negative Sequence Overcurrent Protection (46)

Negative sequence overcurrent protection can be used to provide greater sensitivity to resistive phase to phase or phase to earth faults even with delta transformers present. The negative sequence element can also be used to provide efficient back-up protection for dedicated motor protection relays.

Broken Conductor Detection (46BC)

The broken conductor protection element detects unbalanced conditions caused by broken conductors, maloperation of single phase switchgear or single phasing conditions.

Undercurrent Protection (37)

The P521 provides undercurrent detection that can be used to provide loss of mains protection.

Thermal Overload (49)

Transformers and cables must be protected to account for their particular thermal characteristics. The MiCOM P521 relay includes a thermal overload element based upon the true RMS value of the current. Alarm and overload thresholds are fully programmable to match each device requirement.

Cold Load Pickup

When a feeder is energised after a long outage most connected devices will draw a significant inrush current. The inrush current may be greater than the overcurrent or earth fault settings thus causing mal-operation. To prevent unwanted tripping the P521 has a cold load pickup function that automatically increases the overcurrent settings for a selectable time. Following a successful close the settings revert back to their normal values.

Protection signalling

Interfacing Options

The MiCOM P521 relay is designed to ensure compatibility with a wide range of communication equipment and media. It is supplied fitted with one of the following protection signalling interfaces (order option):

- 1300nm single-mode fibre
- EIA(RS)485 electrical

These interfaces allow a variety of signalling links to be used, as shown in Figure 3 and summarised below. Signalling bandwidths of 9.6 / 19.2 / 56 / 64 kbps are available, subject to the type of link used.

MiCOM P521

Protection functions

(cont.)

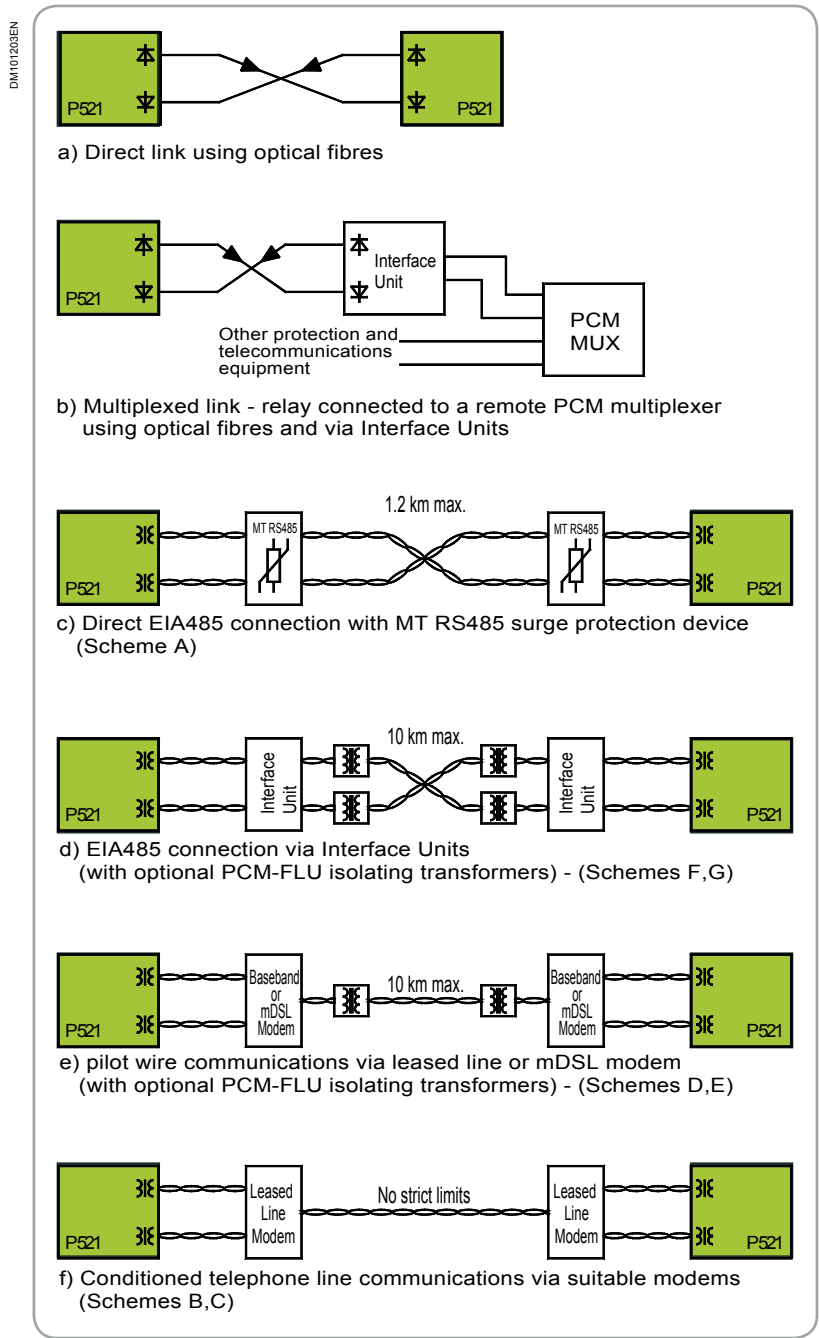

Fig.3 : Protection Signalling options

3

Where 4 wire unconditioned twisted-pair metallic pilots are available, distances up to 25km can be achieved using Interface Units. For distances less than 1.2km, direct 4 wire EIA(RS)485 connection can be used.

For 2 or 4 wire unconditioned twisted-pair metallic pilots, options for other modems exist, allowing distances up to 18km to be achieved.

For 2 wire conditioned pilots (provided by a telecommunications company), a suitable type of modem must be used, and there is no strict limit to the distance.

For connection to multiplexer equipment, electrical interfaces conforming to the G.703, V.35, and X.21 recommendations are available, by using the 850nm fibre interface in the P521.

In direct fibre optic applications, the distance achievable depends on the type of fibre interface:

- 1300nm single-mode
Typical fibre run: 100 km

The P521 protection signalling interface is interchangeable, which allows simple upgrade without the need for any software changes.

MiCOM P521

Protection functions

(cont.)

Direct Intertripping

A typical application of the user defined direct intertripping facility is shown in Figure 4.

Fig.4 : Example Application of Direct Intertripping

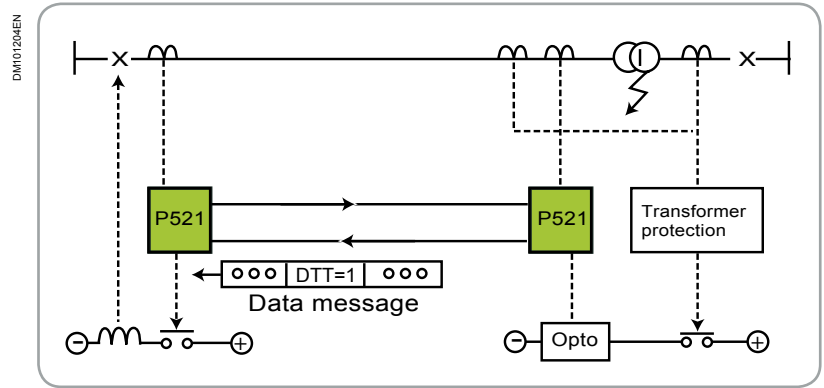

Using the selective Intertrip settings, either a user-configurable input or an internal status signal can be assigned for this purpose. Upon receipt of this message the remote relay will operate user specified outputs for direct transfer tripping or blocking, and provide indication of the remote intertrip. The indication can be disabled then it acts as signal transfer function.

3

Permissive Intertripping

There is an auxiliary signalling facility whereby a permissive intertrip command is sent over the protection communication channel. A user configurable input can be assigned for this purpose. When energised, the communication message to the remote relay is modified. Upon receipt of this message, and providing one or more currents are above the differential setting (Is1), the remote relays will initiate a trip, operate the user defined outputs and provide an indication of the remote intertrip. If required the current checking can be disabled thus enabling the permissive intertrip feature to operate as a second direct intertrip function. The indication can be disabled then it acts as signal transfer function.

Programmable Intertripping

There are 4 independent programmable intertripping signals which can be assigned with any logic inputs, protection signals and logic equation outputs and transfer these signals to the remote end relay.

Control functions

Independent Protection Setting Groups

By virtue of its two setting groups, the MiCOM P521 relay allows for the protection of dual-speed motors as well as motors operating under environmental or operational conditions, which are not constant over time. A change of setting group can be useful following a change in source impedance. The result is improved selectivity.

Circuit Breaker Control

Circuit breaker control is available from the front panel user interface, optically isolated inputs and remotely via the substation communications.

CB Monitoring

Preventive CB maintenance is provided by monitoring summated contact breaking duty, the number of switching operations and the opening time. If a pre-set threshold is exceeded, the P521 relay will generate an alarm signal.

Programmable Inputs and Outputs

The MiCOM P521 relay includes 5 logic inputs and 9 logic outputs including a watch-dog. All inputs and outputs are freely configurable, with the exception of RLY1 which is a dedicated trip relay. RLY1 and RLY2 outputs are changeover contacts, typically used for tripping.

All programmed thresholds (time delayed or instantaneous) can be easily routed to any of the outputs.

Blocking Logic

When the MiCOM P521 relay is used on critical networks, management of protection relays must take surrounding devices into consideration.

Blocking inputs can be configured independently from each other to block any combination of the user selected elements (e.g. current differential, thermal overload, overcurrent etc.).

Selective Relay Scheme Logic

A dedicated input can temporarily alter the overcurrent and earth fault time-delay settings in response to a downstream phase/earth fault start condition. This function allows the MiCOM relay to discriminate correctly when used in a cascade scheme. The selective relay scheme logic function can be enabled or disabled by the user as required.

Output Relay Latching

Any of the outputs, including trip, can be latched. Reset of the outputs is possible from a logic input, the front panel user interface or through the remote communications.

Boolean Logic Equations

A total of 8 logic equations are available, each with 16 variables. The variables can be logic input, protection signals, output of other equations, etc.

(cont.)

Measurements & post fault analysis

Event Recording

Up to 250 events are stored in the MiCOM P521 relay's Flash memory. Events include the change in state of inputs/outputs and presence of any alarms. All events are time-tagged to 1ms.

Fault Records

Records of the last 25 faults are stored in Flash memory. The information provided in the fault record includes:

- Indication of faulted phase
- Protection flags
- Active setting group
- Local phase and neutral currents
- Differential currents
- Maximum bias current
- Communications channel status
- Fault time and date

Disturbance Recording

A total of 5 disturbance records can be stored with 15 seconds in total duration. The disturbance recorder function is triggered by any of the programmable thresholds, by an external input, or via the remote communications. The data is stored in memory and can be transferred to a data analyser using the front communication port or the rear EIA(RS)485 port.

Instantaneous Records

Five instantaneous (start) records can be stored in the MiCOM P521 relay. Each instantaneous record includes:

- Start time (date & duration)
- Origin (phase & earth threshold)

These records are intended to aid preventative maintenance.

Measurements

General Measurements

- Local and remote phase currents
- Local neutral current
- Phase differential currents
- Phase bias currents
- Sequence currents
- Thermal state
- Peak and rolling demand values

Protection Signalling Supervision

Dependable communications are essential for high-performance differential protection. The MiCOM P521 monitors the protection signalling channel, and reports the following error statistics in line with the guidance from ITU-T G.821.

- Channel propagation delay
- Channel status
- Number of valid messages
- Number of errored messages
- Number of errored seconds
- Number of severely errored seconds

MiCOM P521

Control & Monitoring

(cont.)

Plant supervision

Circuit Breaker Failure Protection

If the fault current has not been interrupted following a set time delay from circuit breaker trip initiation, the P521 can be configured to initiate a circuit breaker failure (CBF) condition. CBF operation can be used to backtrip upstream breakers or remove blocking signals from upstream relays.

Circuit Breaker Supervision and Monitoring

The MiCOM P521 relay provides advanced circuit breaker monitoring features. The relay monitors the operating and closing times of the CB to ensure that they do not exceed adjustable thresholds. The state of the circuit breaker is also monitored by use of the CB auxiliary contacts.

If the relay detects the circuit breaker contacts in the same state for more than 5 seconds the relay will initiate an alarm. During faults, I and I2 values are summed and memorised for each phase.

The MiCOM P521 relay also provides Trip Circuit Supervision via a user definable input. Any break in the trip circuit will be accompanied by an alarm.

Current Transformer Supervision

This innovative CTS function can detect a CT failure by comparing the load currents and unbalanced currents of local and remote end. Upon the detection of a CT failure, the negative sequence overcurrent, undercurrent and broken conductor protection will be inhibited. The differential protection can be restrained upon the setting.

Information interfaces

Information exchange is performed via the LCD, the local PC interface and via the rear communications interface.

Local Communication

The front EIA(RS)232 port has been designed for use with MiCOM S1, providing the ability to programme the settings (on or off-line), configure the relay, extract and view records, view the measurement information dynamically and perform control functions.

Remote Communication

The rear communication port is based upon EIA(RS)485 voltage levels and is designed for permanent connection to network control and data acquisition systems (see Figure 5). One of the three protocols listed below should be selected at the time of order:

- Modbus
- IEC 60870-5-103

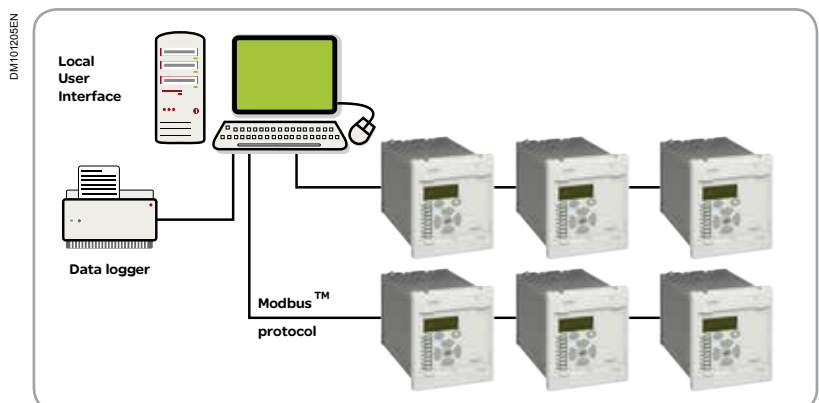

Fig. 5 : Connect to Control System

Protection functions setting ranges

Functions	Setting range		
	min.	max.	Steps
[37] Undercurrent			
I< ?	Yes, No		
I<	0.02 I _n	1 I _n	0.01 I _n
tI<	0 s	150 s	0.01 s
[46] Negative Sequence Overcurrent			
I2> ?	Yes, No		
I2>	0.1 I _n	40 I _n	0.01 I _n
I2> Delay Type	DMT, IDMT, RI		
tI2>	0 s	150 s	0.01 s
I2> Curve	IEC ST1, IEC S1, IEC V1, IEC E1, IEC LTI, CO2, IEEE M1, CO8, IEEE V1, IEEE E1		
I2> Tms	0.025	1.5	0.025
I2> Time Dial	0.1	100	0.1
K	0.1	10	0.005
Reset Type	DMT	IDMT	N/A
tReset	40 ms	100 s	0.01 s
Rtms	0.025	3.2	0.025
I2>> ?	Yes, No		
I2>>	0.1 I _n	40 I _n	0.01 I _n
tI2>>	0 s	150 s	0.01 s
[49] Thermal Overload			
Therm OL	Yes, No		
Iθ>	0.1 I _n	3.2 I _n	0.01 I _n
Te	1 mn	200 mn	1 mn
K	1	1.5	0.01
θ Trip	50%	200%	1%
θ Alarm ?	Yes, No		
θ Alarm	50%	200%	1%
[50/51] Phase Overcurrent			
I> ?	Yes, No, Backup		
I>	0.1 I _n	25 I _n	0.01 I _n
I> Delay Type	DMT, IDMT, RI		
tI>	0 s	150 s	0.01 s
I> Curve	IEC ST1, IEC S1, IEC V1, IEC E1, IEC LTI, CO2, IEEE M1, CO8, IEEE V1, IEEE E1		
I> Tms	0.025	1.5	0.025
I> Time Dial	0.1	100	0.1
K	0.1	10	0.005
Reset Type	DMT	IDMT	N/A
tReset	40 ms	100 s	0.01 s
Rtms	0.025	3,2	0.025
I> ?	Yes, No, Backup		
I>>	0.5 I _n	40 I _n	0.05 I _n
{Remaining I>> cells are identical to I> above}			
I>>> ?	Yes, No, Backup		
I>>>	0.5 I _n	40 I _n	0.05 I _n
tI>>>	0 s	150 s	0.01 s
I>>>> ?	Yes, No, Backup		
I>>>>	0.5 I _n	40 I _n	0.05 I _n
tI>>>>	0 s	150 s	0.01 s

MiCOM P521

Setting ranges

(cont.)

Functions	Setting range		
	min.	max.	Steps
[50N/51N] Earth Fault			
le>?	Yes, No, Backup		
le>	<ul style="list-style-type: none"> ■ 0.1 len* ■ 0.01 len** ■ 0.002 len*** 	<ul style="list-style-type: none"> ■ 25 len* ■ 1 len** ■ 1 len*** 	<ul style="list-style-type: none"> ■ 0.01 len* ■ 0.005 len** ■ 0.001 len***
le> Delay Type	DMT, IDMT, RI, LABOR		
tIe>	0 s	150 s	0.01 s
le> Curve	IEC ST1, IEC SI, IEC VI, IEC EI, IEC LTI CO2, IEEE MI, CO8, IEEE EI; 1, 2, 3		
le> Tms	0.025	1.5	0.025
le> Time Dial	0.1	100	0.1
K	0.1	10	0.005
Reset Type	DMT	IDMT	N/A
tReset	40 ms	100 s	0.01 s
Rtms	0.025	3.2	0.025
le>> ?	Yes, No, Backup		
le>>	<ul style="list-style-type: none"> ■ 0.5 len* ■ 0.01 len** ■ 0.002 len*** 	<ul style="list-style-type: none"> ■ 40 len* ■ 8 len** ■ 1 len*** 	<ul style="list-style-type: none"> ■ 0.01 len* ■ 0.005 len** ■ 0.001 len***
{Remaining le>> cells are identical to le> above}			
Ie>>> ?	Yes, No, Backup		
Ie>>>	<ul style="list-style-type: none"> ■ 0.5 len* ■ 0.01 len** ■ 0.002 len*** 	<ul style="list-style-type: none"> ■ 40 len* ■ 8 len** ■ 1 len*** 	<ul style="list-style-type: none"> ■ 0.01 len* ■ 0.005 len** ■ 0.001 len***
tIe>>>	0 s	150 s	0.01 s
Ie>>>> ?	Yes, No, Backup		
Ie>>>>	<ul style="list-style-type: none"> ■ 0.5 len* ■ 0.01 len** ■ 0.002 len*** 	<ul style="list-style-type: none"> ■ 40 len* ■ 8 len** ■ 1 len*** 	<ul style="list-style-type: none"> ■ 0.01 len* ■ 0.005 len** ■ 0.001 len***
tIe>>>>	0 s	150 s	0.01s
* standard earth fault board (0.1 to 40 len) / ** sensitive earth fault board (0.01 to 8 len) / *** very sensitive earth fault board (0.002 to 1 len)			
[87] Current Differential			
Current Diff ?	No	Yes	N/A
Is1	0.1 In	2 In	0.05 In
Is2	1In	30 In	0.05 In
k1	0%	150%	5%
k2	30%	150%	5%
IDiff Delay Type	DMT	IDMT	N/A
tIdiff	0s	150s	0.01s
IDiff Curve	IEC ST1, IEC SI, IEC VI, IEC EI, IEC LTI, CO2, IEEE MI, CO8, IEEE VI		
IDiff Tms	0.025	1.5	0.025
IDiff Time Dial	0.1	100	0.1
PIT Time	0.05s	2s	0.01s
PIT I Disable	No	Yes	N/A
PIT I Selection	Local	Remote	N/A
{Remaining I>>> cells are identical to I> above}	0.1 s	5 s	0.05 s
DIT Rx tDwell	No	Yes	N/A
DIT Alarm	No	Yes	N/A
PIT Alarm	No	Yes	N/A
Inrush Restraint	4 In	Yes	N/A
High Set	3	32 In	0.01 In
Kr	5%	20	1
Harmonic Ratio	No	50%	N/A
Transient Bias	Yes or No		

3

(cont.)

Automation functions setting ranges

Functions	Setting range		
	min.	max.	Steps
Cold Load PU			
tI>?	Yes or No		
tI>>?	Yes or No		
tI>>>?	Yes or No		
tI>>>>?	Yes or No		
tIe>?	Yes or No		
tIe>>?	Yes or No		
tIe>>>?	Yes or No		
tIe>>>>	Yes or No		
tI2>?	Yes or No		
tI2>>?	Yes or No		
tTherml	Yes or No		
Level	20%	500%	1%
tCL	0.1 s	3600 s	0.1 s
CT Data			
Phase CT Primary	1	9999	1
Earth CT Primary	1	9999	1
Phase CT Secondary	1	5	
Earth CT Secondary	1	5	
CT Correction Factor	0.05	10.0	0.01
Earth Current	Residual Connection or Core Balanced CT (preferred in isolated and compensated neutral systems)		
CT Supervision			
CTS ?	Yes or No		
CTS Reset mode	Manual, Auto		
CTS Reset RST=[C]	Press key (C) to reset CTS alarm. Visible only when CTS Reset mode is set in Manual.		
CTS I1>	0.050 In	4 In	0.01 In
CTS I2/I1>	5%	100%	5%
CTS I2/I1>>	5%	100%	5%
CTS TIME DLY	0 s	10 s	0.01 s
CTS Restrain?	Yes or No		
Trip Circuit Supervision			
TC Supervision ?	Yes or No		
tSUP	100 ms	10 s	50 ms
Logic Select. 1 (2)			
Sel1 tI>>	Yes or No		
Sel1 tI>>>	Yes or No		
Sel1 tI>>>>	Yes or No		
Sel1 tIe>>	Yes or No		
Sel1 tIe>>>	Yes or No		
Sel1 tIe>>>>	Yes or No		
tSel1	0 s	150 s	0.01 s
Auxiliary timers			
Number	2 independent associated to the Logic Inputs Aux 1 and Aux2		
tAux1 & tAux2	0 s	200 s	0.01 s

MiCOM P521

Setting ranges

(cont.)

Functions	Setting range		
	min.	max.	Steps
Latch Functions			
Latch Idiff	Yes or No		
Latch Direct I-Trip	Yes or No		
Latch C Diff I-Trip	Yes or No		
Latch PIT	Yes or No		
Latch tI>	Yes or No		
Latch tI>>	Yes or No		
Latch tI>>>	Yes or No		
Latch tI>>>>	Yes or No		
Latch tIe>	Yes or No		
Latch tIe>>	Yes or No		
Latch tIe>>>	Yes or No		
Latch tIe>>>>	Yes or No		
Latch tI<	Yes or No		
Latch tI2>	Yes or No		
Latch tI2>>	Yes or No		
Latch Thermal θ	Yes or No		
Latch Brkn. Cond	Yes or No		
Latch t Aux 1	Yes or No		
Latch t Aux 2	Yes or No		
Blocking Logic 1 (2)			
Block Idiff	Yes or No		
Block tI>	Yes or No		
Block tI>>	Yes or No		
Block tI>>>	Yes or No		
Block tI>>>>	Yes or No		
Block tIe>	Yes or No		
Block tIe>>	Yes or No		
Block tIe>>>	Yes or No		
Block tIe>>>>	Yes or No		
Block tI2>	Yes or No		
Block tI2>>	Yes or No		
Block Therm θ	Yes or No		
Block Brkn. Cond	Yes or No		
Block t Aux 1	Yes or No		
Block t Aux 2	Yes or No		

Recording functions setting ranges

Functions	Setting range		
	min.	max.	Steps
Disturbance Recorder			
Pre-Time	0.1 s	3 s	0.1 s
<i>Note: From V12.A the Post-Time setting cell is removed from setting</i>			
Post-Time	0.1 s	3 s	0.1 s
Disturb Rec Trig	ON INST, ON TRIP		



Presentation

User-Machine Interface (HMI) - Front Plate and Menus

All the relay's parameters, ie., protection functions, logic controls, communication, LEDs, inputs and outputs, can be programmed and modified by push-buttons located on the front panel. A 2 x 16 alphanumeric backli LCD screen displays all the relay's data (settings, measurements, etc.).

The menus are designed so that the user can move around them easily, without confusion. The user will soon be at ease with the Human-Machine Interface.

Working language

The following languages can be settable in most of the relays:

- French, English, Spanish, Portuguese, Turkish, Polish, Russian, Chinese, Dutch, German, Italian, Czech, Hungarian and Greek.

Wiring

The individual equipment is delivered with sufficient M4 screws and washers to connect the relay via insulated crimp/pressure ring terminals. The maximum number of insulated crimp/pressure ring terminations, per terminal block terminal shall be two.

If necessary, Schneider Electric can provide 3 types of suitable insulated crimp/pressure terminals (see below) according to the cross sectional area of the wire and the type of terminal. Each reference corresponds to a sachet of 100 terminals.

Communication

- EIA(RS)485 Rear Communication Port

The connection of communications is allocated to terminals 29-30-31-32, shown in the connection diagrams in section P521/EN CO of the P521 Technical Guide.

- EIA(RS)232 Front Communication Port

MiCOM P521 relay provides the user with an EIA(RS)232 communication port. This link is dedicated to the MiCOM Setting software MiCOM S1.

A standard EIA(RS)232 shielded cable should be used to connect the P521 front EIA(RS)232 port to a PC. The connector on the P521 side must be male in gender.

Type Port	Physical Link	Connectors	Data Rate	Protocol
RS485 Rear port	Screened twisted pair	Screws or snap-on	■ 300 to 38400 baud (programmable)	■ ModBus™ RTU ■ IEC60870-5-103
RS232 Front port	Screened twisted cable	PC: 9 pin D-type male connector P521: Sub-D 9 pin female connector	■ 19200 Baud (Asynchronous)	■ ModBus™ RTU



MiCOM P521

Base Unit

(cont.)

Dimensions & weight

Case

The MiCOM P521 relay is available in a MiCOM size 30TE metal case for panel or flush mounting.

Dimensions

■ Height	177mm
■ Width	154,2 mm (30TE)
■ Depth	247,1 mm

Weight

■ Weight	approx. 4 Kg
----------	--------------

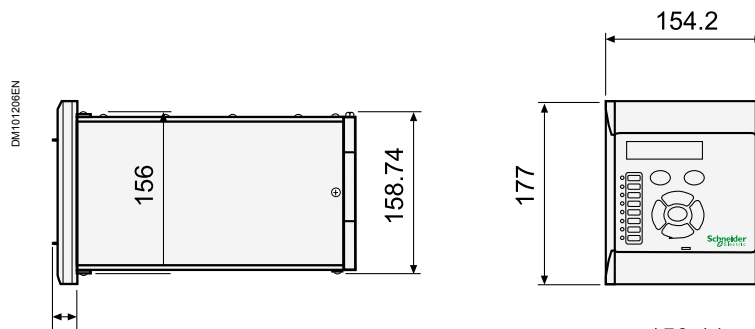

All dimensions in mm

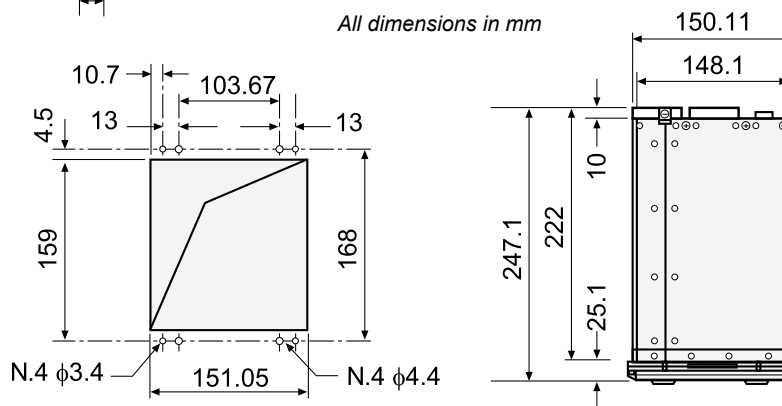

3

Front panel description

- 1 2 x 16 alphanumeric backlit display
- 2 Trip LED
- 3 Alarm LED
- 4 Warning LED
- 5 Healthy LED
- 6 Programmable LEDs
- 7 2 tactile button keypad for reading and clearing alarms and messages
- 8 5 tactile button keypad for setting and consulting
- 9 EAI (RS232) port

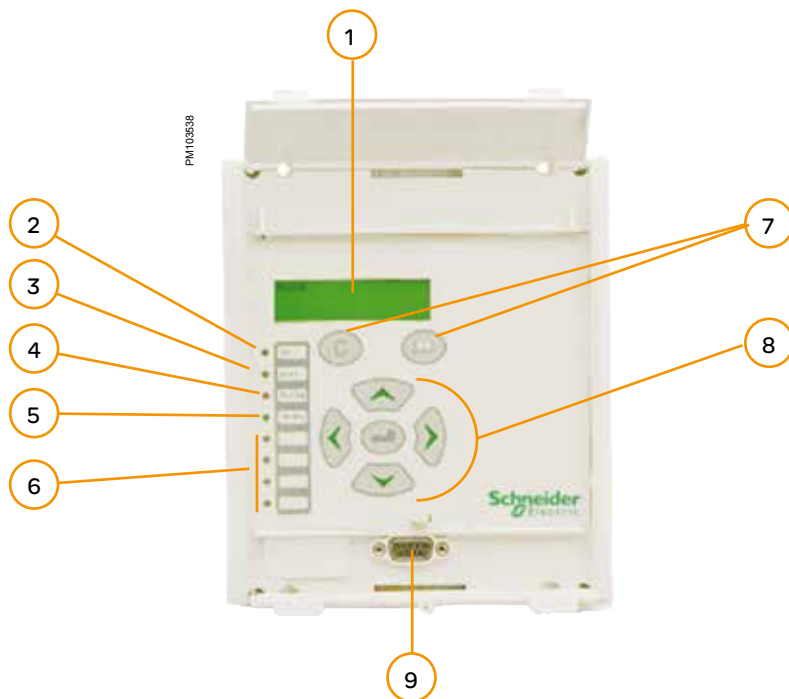

MiCOM P521

Base Unit

(cont.)

P521: Advice for external connections

External connections - with fiber optic communications

DM1101207EN

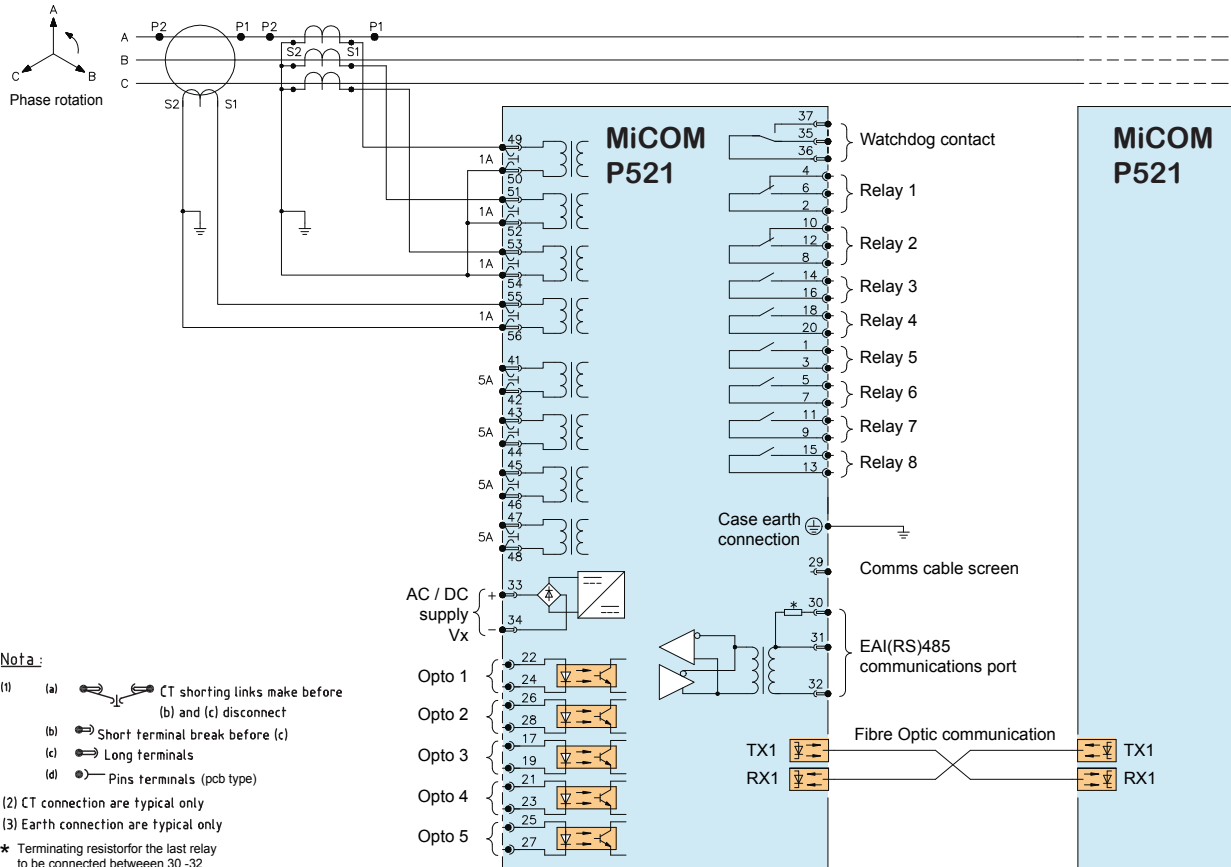

3

(cont.)

P521: Advice for external connections

External connections - with direct EIA(RS)485 communications

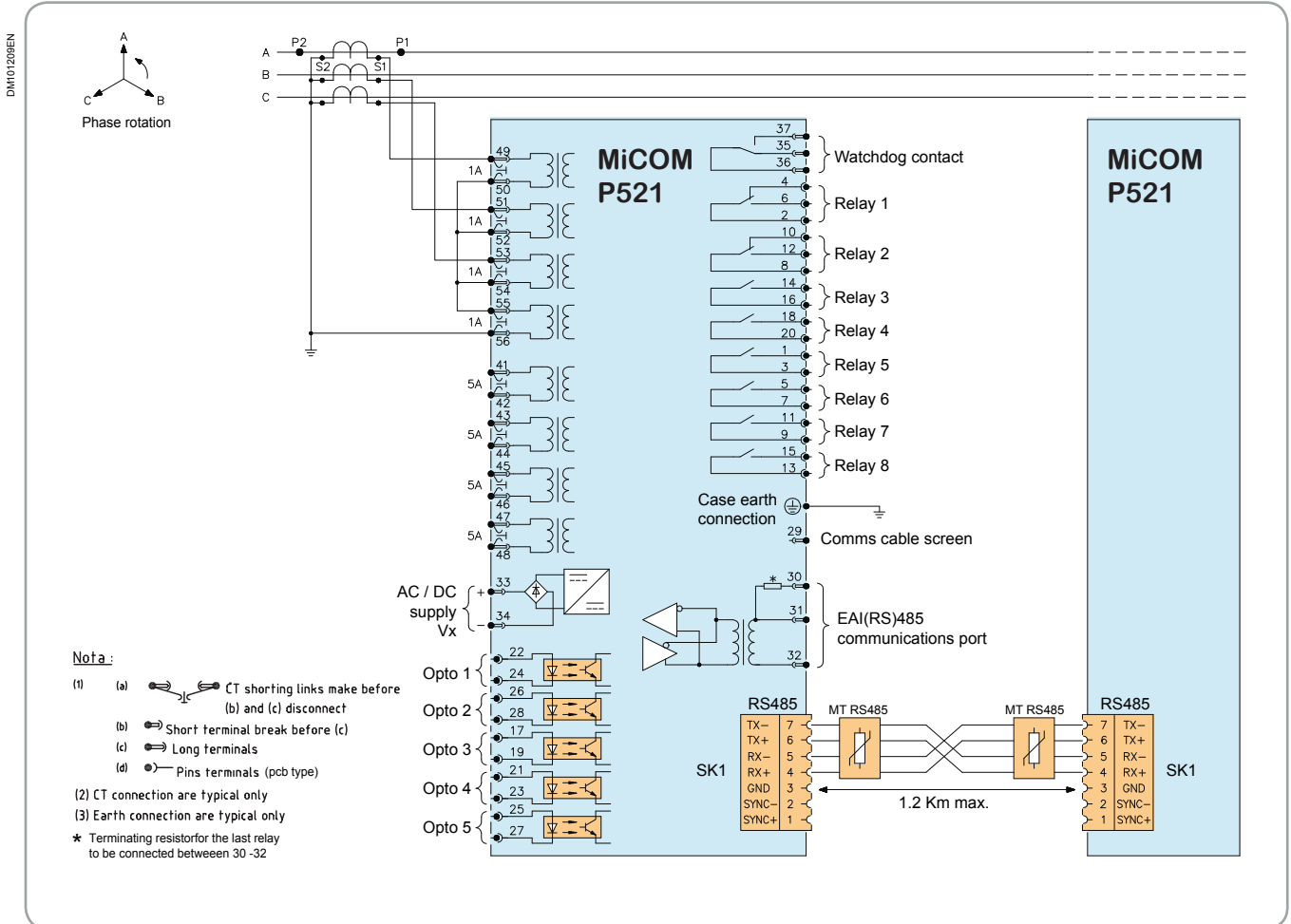

3

MiCOM P921 / P922 / P923

Voltage and Frequency protection relays description



MiCOM P92x range of relays provide reliable and high performance voltage and frequency protection.

Versatile application and integration of protection functions with automation, control and measurement functions, combined with reduced maintenance, makes P92x relays an optimal and innovative choice.

A friendly, multi-lingual user interface with programmable LEDs and boolean logic equation, allows for simple and flexible applications on any type of network.

Connecting the relay to virtually any kind of Digital Control System or SCADA is made possible by the wide range of updated communication protocols provided in P92x.

Application

The MiCOM P92x relays provide fast and accurate protection for use in numerous applications requiring voltage and frequency based protection elements. To suit different application needs and provide optimum solution, following models are available:

P921:

Voltage protection, 2 logic inputs, 4 outputs.

P922:

Voltage and frequency protection, event and fault records, disturbance recorder, 5 logic inputs, and 8 output contacts.

P923:

Voltage and frequency protection (plus the rate of change of frequency element df/dt , and rate of change of voltage $\Delta U/\Delta T$), event and fault records, disturbance recorder, 5 logic inputs, 8 output contacts.

Integrated with 3 independent phase over voltage and phase under voltage thresholds, MiCOM P921, P922 and P923 relays provide effective voltage protection for typical applications like protection of motors, generators, etc. The configurable detection logic (AND, OR) can also indicate the absence of voltage, when the under voltage protection is used.

The 3 zero-sequence over voltage thresholds available in P921, P922 & P923 relays can be applied:

- to detect earth faults at the neutral point of generators, as the relays are insensitive to the 3rd harmonics
- to detect earth faults in high impedance earthed or isolated electrical systems .

The negative sequence over voltage protection provided by the P922 and P923 relays is designed to detect unbalanced conditions it could therefore be used for motor, in which any unbalance will lead to overheating and damage.

The P922 and P923 relays integrate 6 frequency thresholds programmable as under or over frequency, which can be used for automated load shedding/load restoration.

In addition, the P923 relays provide:

- 6 thresholds of instantaneous Rate of Change of Frequency (df/dt) or average measurements over a settable time interval.
- 4 thresholds of $\Delta U/\Delta T$ function to be used for automated load shedding/load restoration.

3

MiCOM P92x:

- Optimized solution to provide efficient protection
- Flexible communication and powerful post fault analysis tools.



Customer benefits

- Frequency measurement accuracy better than 0.01Hz
- Option of multiple communication protocols
- Boolean logic equations
- Housed in a compact case

Inputs and Outputs Ratings

Power Supply	
Nominal auxiliary voltage Vx	<ul style="list-style-type: none"> ■ 24 -250 Vdc ■ 24 – 240 Vac
Operating range	<ul style="list-style-type: none"> ■ 19.2 – 300 Vdc ■ 19.2 – 264 Vac
Residual ripple	12%
Stored energy time	50 ms
Burden	3 W (with 50% of the optos energized and one relay per card energized)
Frequency	
Nominal value 50Hz	Operating range 40 – 60 Hz
Nominal value 60 Hz	Operating range 50 – 70 Hz
Output Relay	
Contact rating	
Contact relay	Dry contact Ag NI
Make current	30 Amps and carry for 3 s
Carry capacity	5 Amps continuous
Rated Voltage	250Vac
Breaking characteristic	
Breaking capacity AC	<ul style="list-style-type: none"> ■ 1500VA resistive ■ 1500VA inductive (cos ϕ =0.5)
Breaking capacity DC	<ul style="list-style-type: none"> ■ 50W resistive ■ 25W inductive (L/R = 40ms)
Operation time	<7ms
Durability	
Loaded contact	>10 000 Operations
Unloaded contact	>100 000 Operations

Relay auxiliary power supply		Logic Inputs				
Nominal voltage range Vx	Operating voltage range	Nominal Voltage range	Minimal polarisation voltage	Maximum polarisation current	Holding current after 2 ms	Maximum continuous withstand
<ul style="list-style-type: none"> ■ 24 – 250 Vdc ■ 24 – 240 Vac 	<ul style="list-style-type: none"> ■ 19.2 – 300 Vdc ■ 38.4 – 264 Vac 	<ul style="list-style-type: none"> ■ 24 – 250 Vdc ■ 24 – 240 Vac 	<ul style="list-style-type: none"> ■ 19,2 Vdc ■ 19,2 Vac 	<ul style="list-style-type: none"> ■ 35 mA 	<ul style="list-style-type: none"> ■ 2.3 mA 	<ul style="list-style-type: none"> ■ 300 Vdc ■ 264 Vac



Functional overview

(Description of ANSI code nos., see Protection Functions Table)

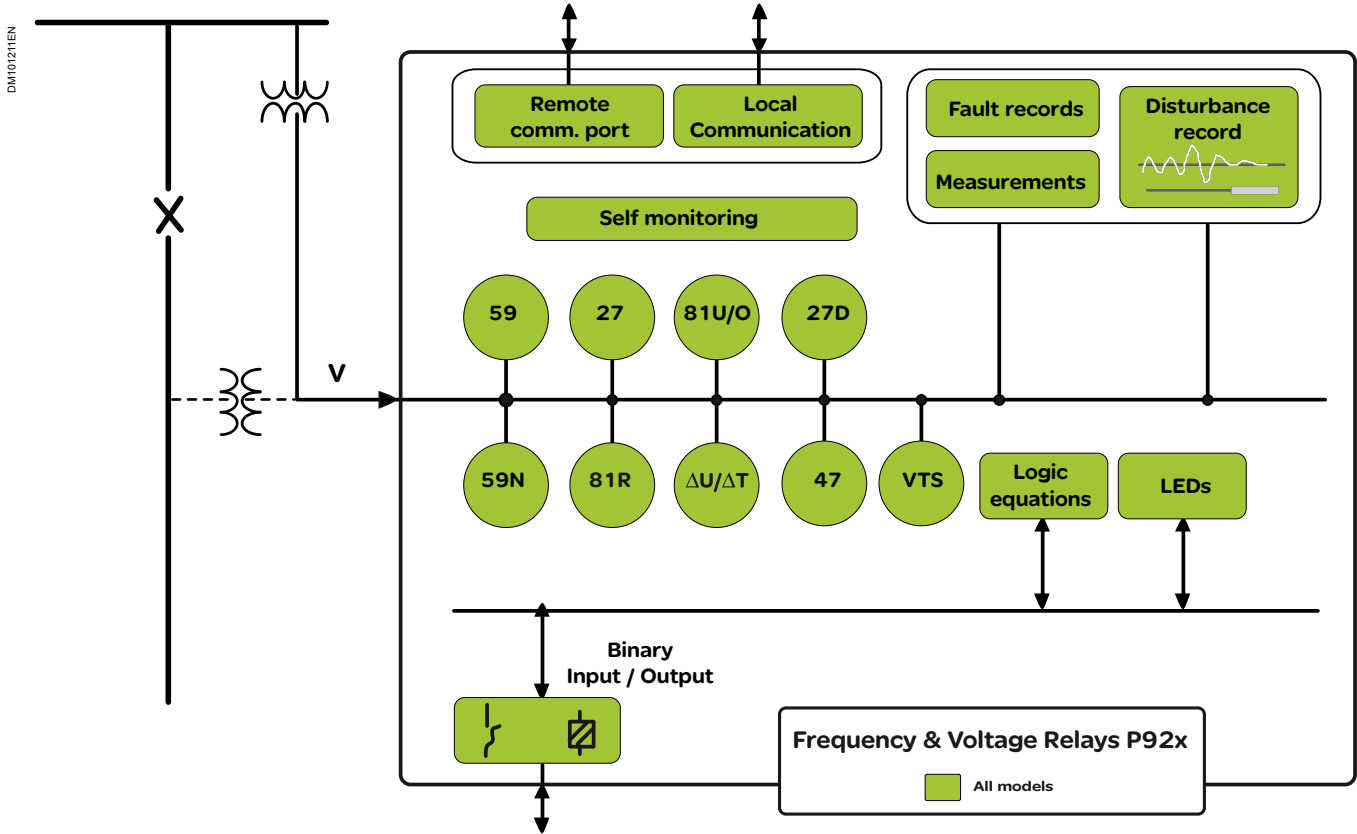

ANSI	Function	P921	P922	P923
27/59	Phase under/over voltage (AND & OR mode)	■	■	■
27D	Positive sequence under voltage		■	■
47	Negative sequence overvoltage		■	■
59N	Residual over voltage / Derived Vo sequence overvoltage	■	■	■
VTS/ 60	Voltage transformer supervision		■	■
81U/O	Under/over frequency		■	■
81R	Rate of change of Frequency (df/dt+t)			■
86	Output relay latching	■	■	■
	$\Delta U / \Delta T$			■
	Phase-to-neutral or phase-to-phase voltage protection	■	■	■
	Time synchronisation (via digital input)		■	■
	Logic equation (AND / OR and NOT gates)	■	■	■
	VT Supervision		■	■
	CB Supervision	■	■	■
	Configuration depending on the number and type of voltage transformers	■	■	■
	Blocking logic	■	■	■
	Under voltage Blocking (settable for P923)			■

Function	P921	P922	P923
Settable hysteresis	■	■	■
Remote communication (RS485 port)	■	■	■
Local communication (RS232 port)	■	■	■
Digital inputs	2	5	5
Output relays	4	8	8
Event recording		250	250
Fault recording		25	25
Disturbance recording		5	5
Setting groups	1	2	2

Management functions

The protection functions in P92x are complemented with a wide range of control, measurement, monitoring, post fault analysis and self-diagnostic features to assist efficient management of the primary system. These include:

- Boolean logic equation
- Programmable logic inputs and outputs
- Fail safe operation
- Circuit breaker control
- Output contact latching
- Circuit breaker status
- Circuit breaker condition monitoring (in P922 & P923)
- 2 setting groups (in P922 & P923)
- True rms phase to phase, phase to neutral and residual voltage measurement.

Zero-sequence overvoltage (59N)

Three thresholds are available: each one can be independently activated or deactivated. Depending on the VT configuration, MiCOM P921, P922 and P923 relays will operate from the zero sequence voltage, which is calculated internally, or from the residual voltage, which is measured directly.

A software band-pass filter with an attenuation of 60 dB / decade and centered on the fundamental frequency (50 or 60 Hz) is provided. The filter can be enabled or disabled according to the setting.

Configuration depending on the VT

The relays can be used in the following configurations:

- “3 phase-neutral VTs” or “3 phase-neutral VTs and 1 residual VT”:
The voltage protection element can therefore operate either from measured phase-to-neutral voltages, or from phase-to-phase voltages which have been internally calculated by the relay. Zero-sequence over voltage protection will always be available; the presence of the residual VT is designed to display the true RMS value of the residual voltage,
- “3 phase-phase VTs and 1 residual VT” or “2 phase-phase VTs and 1 residual VT”:
The voltage protection element can only operate from measured phase-to-phase voltages. If the residual VT is not connected, the zero-sequence over voltage protection will not be available.
- The MiCOM P922 is only designed to operate with the “3 phase-neutral VTs” or “3 phase-phase VTs” configuration.

Voltage protection

For each of the voltage protection function listed below, an instantaneous signal and a time delayed signal is available for each threshold.

For time-delayed signals, the first threshold of each function (“low threshold”) offers the choice between a definite timer and an inverse timer, to which a reset timer can be assigned. The other thresholds only have one definite timer.

In the case of the MiCOM P922, all thresholds have definite time delays and the only detection logic is the “OR” logic.

Under / Overvoltage (27/59)

Three thresholds are available for each function: each one can be independently activated or deactivated. If a threshold is activated, it can be configured to detect:

- an over voltage on the 3 simultaneous phases (logic “AND”) or on at least one of the phases (logic “OR”) for the “Over voltage” function
- an under voltage on the 3 simultaneous phases (absence of voltage with the “AND” logic) or on at least one of the phases (logic “OR”) for the “Under voltage” function
- The MiCOM P921, P922 and P923 relays provide a programmable hysteresis (drop-out / pick-up ratio) as a percentage of the under voltage and over voltage pick-up values.
- The P923 provides a settable under voltage block of all the protection and control elements based on the frequency.

P922 & P923: Negative Sequence Overvoltage (47)

Two thresholds are available: each one can be independently activated or deactivated. This function is based on the negative-sequence component of the voltage, which is calculated internally and displayed on the screen of the front panel: It is designed to detect any voltage unbalance condition.

P922 & P923: Positive Sequence Undervoltage (27D)

Two thresholds are available: each one can be independently activated or deactivated. This function is based on the positive phase sequence component of the voltage, which is calculated internally.

Output Relay Latching (86)

Latched outputs can be reset via the activation of a logic input through the front panel interface or by remote communication

Frequency protections

Frequency protection functions are inhibited below a certain level of the measured secondary voltage.

The following frequency based protection functions are available.

P922 & P923: Under / Overfrequency (81U/81O)

Six thresholds are available: each one can be configured to detect an under or over frequency within the range $[f_n - 10\text{Hz}, f_n + 10\text{Hz}]$, where f_n is the nominal frequency selected (50Hz or 60Hz). A definite timer is assigned to each threshold.

P923: Rate of Change of Frequency (81R)

Six thresholds are available: each can be configured independently within the range $[-10\text{ Hz/s}, +10\text{ Hz/s}]$.

These functions are based on the calculation of the instantaneous rate of change of frequency over a settable integration time (number of cycles).

P923: $\Delta U/\Delta T$ Function

Four thresholds are available: each can be configured independently within the range $[+/-1\text{V}, +/-200\text{V}]$ or $[+/-4\text{V to +/-720V}]$ for V and $[0, 1\text{s}, 10\text{s}]$ for T.

Boolean logic equation

The MiCOM P921/P922 & P923 relays integrate complete logic equations to allow customization of the product based on customer application.

Up to 8 independent Boolean equations can be used. Each equation offers the possibility to use AND, OR & NOT logical gates. Up to 16 parameters can be used for each equation including any threshold and opto-input status. Every result of equation can be time delayed, reused in another equation and assigned to any output relays, trip, trip latching and/ or HMI LEDs.

Each boolean equation result can be alarmed or not.

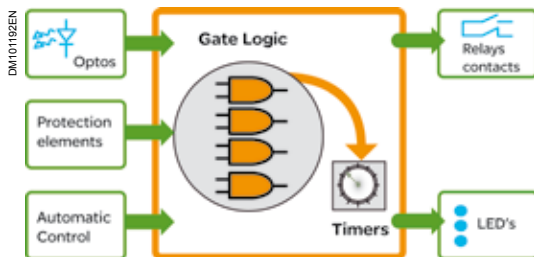

Inputs / Outputs / programmable LEDs

All logic inputs, output contacts (excluding the RL0 changeover output contact, dedicated to the "relay failed" function) and the 4 LEDs of the MiCOM P921, P922 and P923 relays can be programmed. This affects in particular all logic signals (instantaneous, time delayed) in the relays which can be combined with the different output contacts and LEDs. The output contacts can also be programmed to be latched.

Blocking logic

Operation of the different protection elements of P92x can be coordinated with other devices in the system. Two blocking inputs are independently configurable. When active, they freeze the associated protection timers and when they drop-off, they re-impose the initial value if the fault conditions are still present.

Setting groups for protection functions

The MiCOM P922 and P923 relays have two independent setting groups, which can be used to adapt the protection functions to different operating conditions. The two groups can be switched by activating a dedicated logic input, or by the operator via the front panel, or locally (RS232 port) or remotely (RS485 port). The switch from one setting group to another will only take effect if no protection or automation functions are running, to prevent unwanted tripping.

3

Measurements

Depending on the configuration of the VTs connected to MiCOM P921, P922 and P923 relays, the following values will be measured and displayed as true RMS values on the back-lit screen:

- phase-to-neutral voltages U_a, U_b, U_c
- phase-to-phase voltages U_{ab}, U_{bc}, U_{ca}
- residual voltage V_o
- frequency.

In addition, the MiCOM P922 and P923 relays calculate the following values internally:

- positive sequence voltage
- negative sequence voltage
- peak values of phase-to-neutral or phase-to-phase voltages
- rolling values of phase-to-neutral or phase-to-phase voltages

All measurements are available locally or remotely.

Logs and records

All event, fault and disturbance records are time-stamped to 1ms by the internal real time clock. In the event of a loss of auxiliary power, a lithium battery is used to save the records, the date and the time. Monitored at regular intervals, the battery can be easily accessed from the front panel if it has to be replaced.

All records can be retrieved locally, using the MiCOM S1 setting software (RS232 port), or remotely (RS485 port).

Event Records

Any change of state of logic inputs, output contacts or protection functions will be recorded in the non-volatile memory of the MiCOM P922 and P923 relays, with a maximum of 250 events. When the memory is full, the oldest events will be deleted, which will increase the storage capacity for more recent events. Each event can be retrieved locally to a PC using the MiCOM S1 Studio support software through front RS232 port or remotely using the rear RS485 port.

Fault Records

The MiCOM P922 and P923 relays can store the last 25 faults that have occurred in non-volatile memory. Each record provides the following information:

- date and time of fault
- origin of fault (under voltage, etc.)
- faulted phase(s)
- magnitude of the quantity which lead to the fault
- magnitude of phase-to-neutral or phase-to-phase voltages
- magnitude of the zero-sequence voltage (if available)

Disturbance Records

Up to 5 disturbance files are stored in the relays. Even if the total duration is fixed to 15s, it can be fully adjustable for easy adaptation to customer requirements (1s / 3s / 5s / 7s / 9s). They are stored in COMTRADE format. The disturbance recording function is triggered either by any of the programmed thresholds or by an external input, or through the communications. All digital and analogical information are stored in a flash memory and can be transferred using the front communication port or the rear port to be used by an external data analyser. Disturbance records are stored on a non volatile flash memory.

Frequency Disturbance Records

One frequency disturbance record, lasting 20 secs can be stored in non-volatile memory by the MiCOM P923 relay. The sampling frequency is fixed at 1 sample per cycle. The mechanism that triggers the recording can be configured: instantaneous or time delayed tripping, activation of a dedicated logic input or time delayed logic equation signal.

EM100054EN

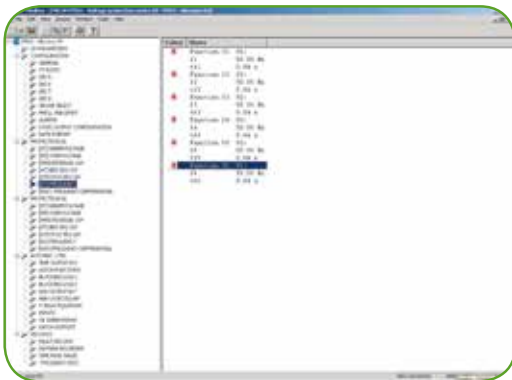

Relay setting using MiCOM S1 Studio

EM100055EN

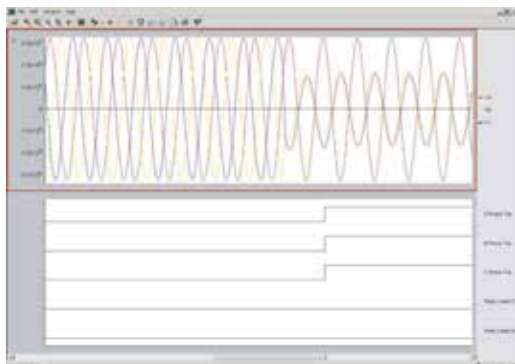

Disturbance record analysis

Circuit breaker status & control

With MiCOM P921, P922 and P923 relays, the circuit breaker can be controlled manually via logic inputs (AUX1 and AUX2), with local or remote communication: the opening and closing commands will therefore activate the programmed output contacts. The LEDs can be programmed to indicate the status of the circuit breaker.

Circuit breaker maintenance

In addition to protecting and controlling the electrical network, the P922 and P923 relays provides preventive and curative maintenance of the circuit breakers. The MiCOM P922 and P923 relays monitor the opening / closing time of the circuit breaker and monitor the number of operations carried out. An alarm is triggered as soon as the maximum opening or closing time, or the maximum permitted number of operations is exceeded.

Communications

Two communication ports are available on MiCOM P921, P922 and P923 relays: A rear RS485 port for remote communication and a local front RS232 port for local communication.

A MiCOM S1 Studio software provided for relay setting, record retrieving and analysis is fully Windows™ compatible. This support Software allows easy setting of any MiCOM relay model including P92x.

Remote Communication

The P921, P922 and P923 relays can be ordered with any one of the following communication protocols.

- MODBUS™
- IEC 60870-5-103

The remote RS485 port can be connected to any SCADA or digital control system to access settings, measurements and alarms as well as all records.

Local Communication

The RS232 port on the front panel of MiCOM P921, P922 and P923 relays has two functions:

- to download a software version to the relay (upgrade, change the language setting, modify the remote communication protocol, etc.)
- to connect a PC which has the setting software

Protection functions setting ranges

Functions	Setting range		
	min.	max.	Steps
[27] Undervoltage			
Threshold settings (secondary values)			
V<= Voltage Set	0.5V	130.0V	0.1V
V<<= Voltage Set	0.5V	130.0V	0.1V
V<<<= Voltage Set	0.5V	130.0V	0.1V
Inverse Time Delay Characteristic			
TMS	0.5 s	100.0 s	0.5 s
tRESET (only DT)	0.00 s	100.00 s	0.1 s
Definite time delay characteristics			
tV<	0 s	599.0 s	0.1 s
tV<<	0 s	599.0 s	0.1 s
tV<<<	0 s	599.0 s	0.1 s
Hysteresis			
Hysteresis	1.02%	1.05%	0.01%
[27D] Positive sequence undervoltage (P922 & P923)			
Threshold settings (secondary values)			
V1<= Voltage Set	5.0	130.0V	0.1V
V1<<= Voltage Set	5.0	130.0V	0.1V
Inverse Time Delay Characteristic			
TMS	0.5	100.0	0.5
tRESET (only DT)	0 s	100.00 s	0.01s
Definite time delay characteristics			
tV1<	0 s	599.00s	0.1 s
tV1<<	0 s	599.00s	0.1 s
Hysteresis			
Hysteresis (fixed)	105%		
[47] Negative sequence overvoltage (P922 & P923)			
Threshold settings (secondary values)			
V2>= Voltage Set	5.0V	200.0V	0.1V
V2>>= Voltage Set	5.0V	260.0V	0.1V
Inverse Time Delay Characteristic			
TMS	0.5	100.0	0.5
tRESET (only DT)	0 s	100.00 s	0.01 s
Definite time delay characteristics			
tV2>	0 s	599.00 s	0.1 s
tV2>>	0 s	599.00 s	0.1 s
Hysteresis			
Hysteresis (fixed)	0.95%	0.95%	

MiCOM P921 / P922 / P923

Setting ranges

(cont.)

Functions	Setting range		
	min.	max.	Steps
[59] Overvoltage			
V>= Voltage Set	0.5V	200.0V	0.1V
V>>= Voltage Set	0.5V	200.0V	0.1V
V>>>= Voltage Se	0.5V	200.0V	0.1V
Inverse Time Delay Characteristic			
TMS	0.5	100.0	0.5
tRESET (only DT)	0 s	100.00 s	0.01 s
Definite time delay characteristics			
tV>	0 s	599.0 s	0.1 s
tV>>	0 s	599.0 s	0.1 s
tV>>>	0 s	599.0 s	0.1 s
Hysteresis			
Hysteresis	0.95	0.98%	
[59N] Residual overvoltage / neutral displacement			
Threshold settings (secondary values)			
Nominal voltage range: 57 – 130V			
V0>= Voltage Set	0.5V	130.0V	0.1V
V0>>= Voltage Set	0.5V	130.0V	0.1V
V0>>>= Voltage Set	0.5V	130.0V	0.1V
Derived voltage range: 57 – 130V (P922 & P923)			
V0der>= Voltage Set	0.5V	130.0V	0.1V
V0der>>= Voltage Set	0.5V	130.0V	0.1V
V0der>>>= Voltage Set	0.5V	130.0V	0.1V
Inverse time delay characteristic			
TMS	0.5	100.0	0.5
tRESET (only DT)	0 s	100.00 s	0.01 s
Definite time delay characteristics			
tV0>	0 s	599.0 s	0.1 s
tV0>>	0 s	599.0 s	0.1 s
tV0>>>	0 s	599.0 s	0.1 s
tV0der>	P922 / P923 ONLY	0 s	599.0 s
tV0der>>		0 s	599.0 s
tV0der>>>		0 s	599.0 s
Hysteresis			
Hysteresis (fixed)	0.95		
[81U/81O] Under/over frequency (P922 & P923)			
Threshold settings			
F1 to F6:	Fn – 10Hz	Fn+ 10Hz	0.01Hz
<i>Where: Fn = nominal frequency</i>			
Definite time delay characteristics			
tF1 to tF6	0 s	599.00 s	0.01s
Minimum voltage to unblock Frequency protection (P923 only)			
Protection blocking threshold	5 or 20	130V or 240V	0.1V

Setting ranges

(cont.)

Functions	Setting range		
	min.	max.	Steps
[81R] Rate of change of frequency (P923)			
Threshold settings			
Df/dt1 to df/dt6:	10Hz/s	10Hz/s	0.01Hz/s
Integration time			
Number of cycles to calculate df/dt:	1	200 cycles	1 cycle
Number of detections for df/dt validation			
Number of df/dt for validation	2 or 4		
$\Delta U/\Delta T$ Function (P923)			
Function and threshold settings for $\Delta U/\Delta T$			
$\Delta U/\Delta T1$	Yes/No		
$\Delta U1$	-720.0V	+720.0V	0.5V
$\Delta T1$	0.1 s	10.0 s	0.01 s
$\Delta U/\Delta T2$	Yes/No		
$\Delta U2$	-720.0V	+720.0V	0.5V
$\Delta T2$	0.1 s	10.0 s	0.01 s
$\Delta U/\Delta T3$	Yes/No		
$\Delta U3$	-720.0V	+720.0V	0.5V
$\Delta T3$	0.1	10.0s	0.01s
$\Delta U/\Delta T4$	Yes/No		
$\Delta U4$	-720.0V	+720.0V	:0.5V
$\Delta T4$	0.1 s	10.0 s	0.01 s
Voltage balance (P923)			
Voltage balance per phase and multi-phase			
K< function=	Yes/No		
K< threshold=	0.50	1	0.01
<i>(common setting for the 3 phases)</i>			
Frequency protections configuration (P922 & P923)			
Number of cycles for validation of frequency threshold (P923)	1	2	
Nr of cycles to calculate df/dt (P923)	1	200	
Minimum voltage to unblock Frequency protection (P923)	5 or 20	130V or 240V	0.1V
Inhibition of "blocking df/dt >20Hz/s" (P923)	Yes/No		
Number of DU/DT for fault validation	2	4	

MiCOM P921 / P922 / P923

Setting ranges

(cont.)

Alarm configuration (P922 /P923)	Setting range
Auto-acknowledgement	Yes/No
Alarm for all models	
"V>, tV>?", "V>>,tV>>?" "V>>>,tV>>>?"	Yes/No
"U<, tU<?", "U<<,tU<<?" "U<<<,tU<<<?"	Yes/No
"tAux1?", "tAux2?"	Yes/No
Boolean equations A to H	Yes/No
P922 & P923 additional alarms	
"tAux3?", "tAux4?" "tAux5" (P922&P923)	Yes/No
Frequency thresholds "F1 ?" to "F6?"	Yes/No
Frequency out of range	Yes/No
VT Supervision	Yes/No
Control trip?	Yes/No
P923 additional alarms	
Voltage variation ("DU/Dt1?" to "DU/DT4?")	Yes/No
Frequency variations "df/dt1?" to "df/dt6?"	Yes/No
Frequency trip AND variation (6 rates)	Yes/No
Voltage balance per phase	Yes/No
Multi-voltage balance (> 2 phases)	Yes/No

3

Control and monitoring functions setting ranges

Functions	Setting range		
	min.	max.	Steps
VT Supervision (P922 & P923)			
VT Supervision	Yes/No		
Detection mode	VTS Input, delta Vr or both		
Delta Vr setting - Range (57-130V)	2	130V	1V
CB Supervision (P922 & P923)			
CB OPEN Supervision	Yes / No		
CB Opening time	0.1 s	5 s	0.05 s
CB CLOSE supervision	Yes/No		
CB Closing time	0.1 s	5 s	0.05 s
NB operation alarm	Yes/No		
Nb operations	0	50000	1
Close pulse time	0.1 s	5 s	0.05 s
Trip pulse time	0.1 s	5 s	0.05 s
Boolean logic equation			
<ul style="list-style-type: none"> ■ 8 independants equations are available ■ Each one can used a maximum of 16 operands among all start and trip signal ■ Each one can used NOT, OR, AND, OR NOT, AND NOT logical gates 			
T operate	0	600s	0.01s
t Reset	0	600s	0.01s

PM103544



3

Presentation

User-Machine Interface (HMI)

The user interface for MiCOM P921, P922 and P923 relays comprises:

- back-lit, 2 x 16 characters LCD display,
- four dedicated LEDs to provide information such as “Trip”, “Alarm”, “Warning” and “Relay Healthy”
- four programmable LEDs: Each one lights up when protection information is displayed, or if a logic input state changes
- five tactile keys for scrolling through the menus and entering settings the pull-down structure of the menus enables quick and easy access to required information
- 1 key for reading and one for acknowledging alarms

Working language

The following languages can be settable in most of the relays:

- French, English, Spanish, Portuguese, Turkish, Polish, Russian, Chinese, Dutch, German, Italian, Czech, Hungarian and Greek.

Wiring

- Rear (double fast on + M4 screw per connection)
- Full draw-out with automatic CT shorting in the case of the relay

Loose relays are supplied with sufficient M4 screws for making connections to the rear mounted terminal blocks using ring terminals, with a recommended maximum of two ring terminals per relay terminal.

Communication

- RS485 rear communication port
All MiCOM relays have an RS485 rear communication port. The terminals 29-30-31-32 are dedicated to the RS485 communication port.
- RS232 front communication port (P921, P922, P923)
MiCOM P921, P922 and P923 relays provide a RS 232 communication port. This port is dedicated to Setting software MiCOM S1 Studio.
The cable between the relay and the PC is a standard RS 232 shielded-cable. The relay requires a RS232 cable with a 9-pin male connector.

Type Port	Physical Link	Connectors	Data Rate	Comms. mode	Protocol
RS485 Rear port	Screened twister pair	Screws or snap-on	<ul style="list-style-type: none"> ■ 9600 or 19200 ■ 300 to 38400 bits/s ■ 1200 to 38400 bits/s 	<ul style="list-style-type: none"> ■ Stop bit: 0 or 1 or 2 ■ Parity: Without/Odd/Even 	<ul style="list-style-type: none"> ■ IEC60870-5-103 ■ ModBus RTU
USB / RS232 Front port	Screened twister pair	PC interface DIN 41652 connector (x6), Type D_SUB, 9_PIN	<ul style="list-style-type: none"> ■ 19200 	<ul style="list-style-type: none"> ■ Data Bit:8 ■ Stop bit: 1 ■ Parity: Without 	<ul style="list-style-type: none"> ■ ModBus RTU

Dimensions & weight

Case

All the models of the MiCOM P92x range have a 4U draw out metal case, and can be flush-mounted in switchboard or panel or rack-mounted. External connections are made via MIDOS type terminal blocks. Each connection includes two 4.8 mm Faston and one M4 screw fixing.

The chassis is normally secured in the case by four screws (Self tap screws 6x1,4), to ensure good seating. The fixing screws should be fitted in normal service (do not add washers). Do not discard these screws.

Dimensions

■ Height	177 mm
■ Width	102.4 mm (20TE)
■ Depth	247.1 mm

Weight

■ P921/P922/P923	approx. 2Kg
------------------	-------------

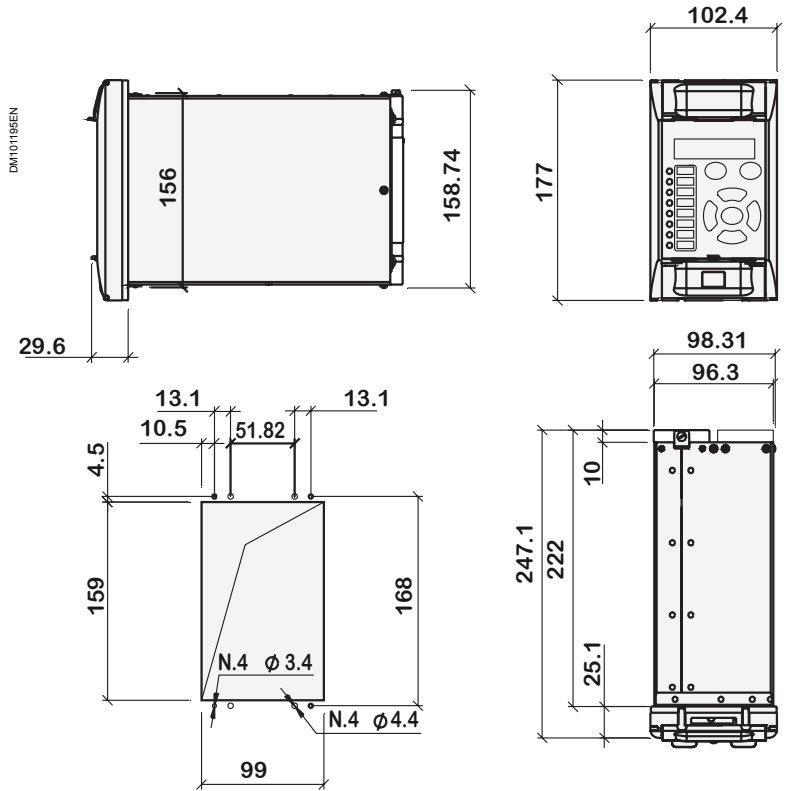

(cont.)

Front panel description

- 1 Top cover
- 2 Clear key)
- 3 Read key
- 4 Key pad (cursor keys)
- 5 Fixed function LEDs
- 6 User programmable function LEDs
- 7 Plastic cover
- 8 Battery (not used)
- 9 Comms front port (RS232)

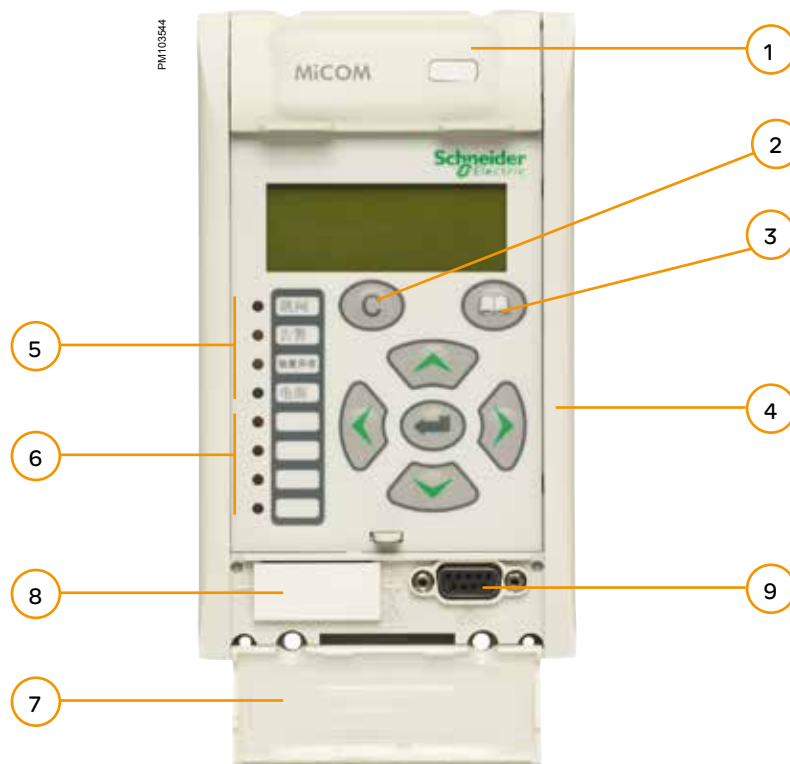

3

MiCOM P921, P922 and P923 case connection diagram

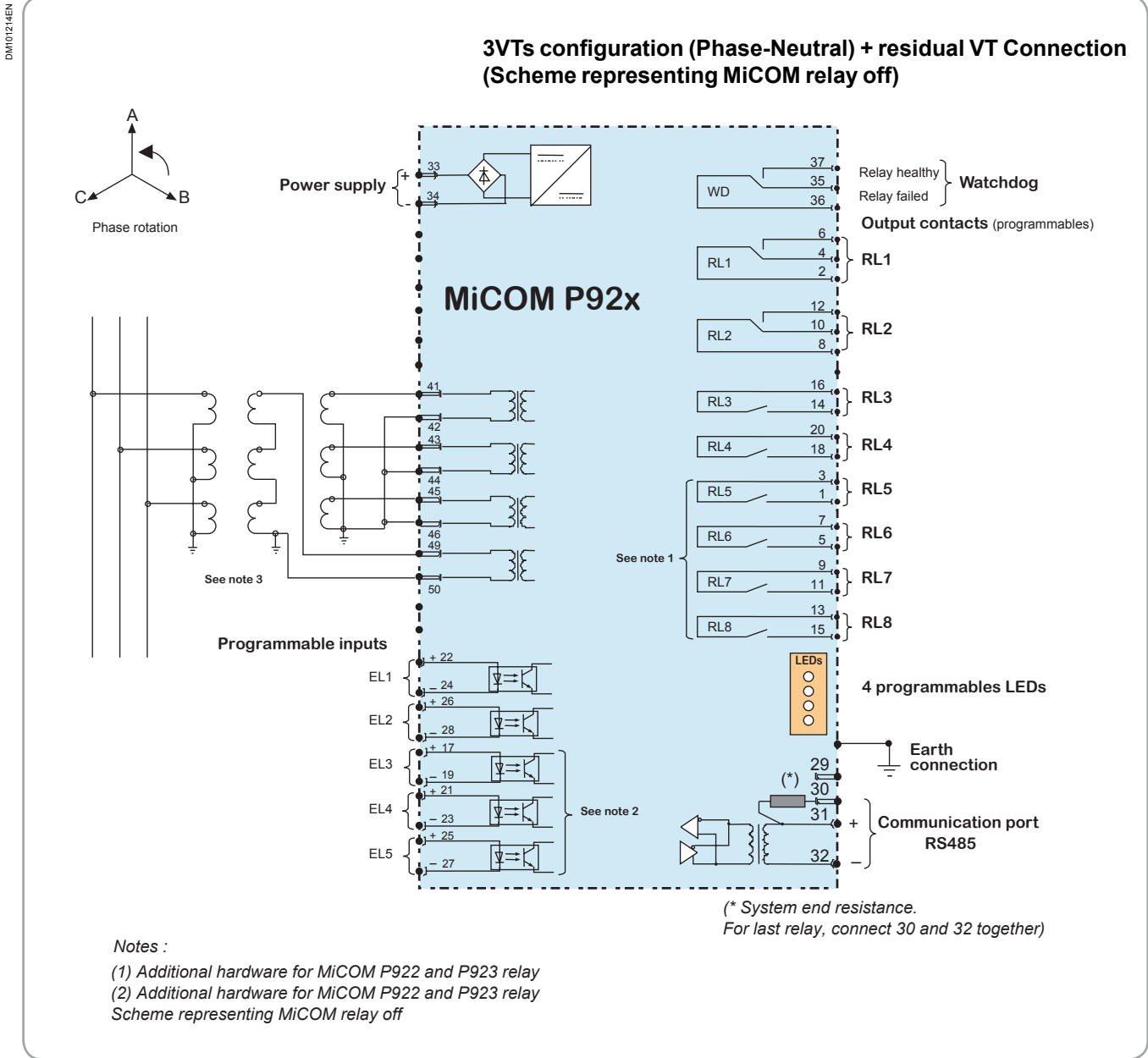

3

> TOOLS

schneider-electric.com

This international site allows you to access all the Schneider Electric products in just 2 clicks via comprehensive range data-sheets, with direct links to:

- complete library: technical documents, catalogs, FAQs, brochures...
- selection guides from the e-catalog.
- product discovery sites and their Flash animations.

You will also find illustrated overviews, news to which you can subscribe, the list of country contacts...



Automation panorama

This animated tool helps you to select the best Automation Intelligent Electronic Device adapted to your need. This CD includes description of all Schneider Electric IEDs ranges (Sepam, MiCOM, VAMP, Easergy). This selector is also included in the Schneider Electric web site.

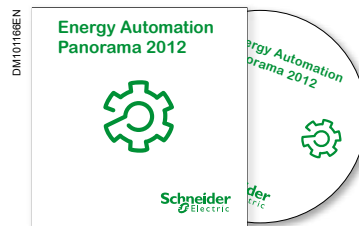

4

MiCOM series 10

MiCOM series 20

Range description	5
MiCOM series 10	25
MiCOM series 20	99
Order form	187
MiCOM series 10	188
MiCOM P111	188
MiCOM P115	190
MiCOM P116	191
MiCOM series 20	193
MiCOM P12x	193
MiCOM P122 / MiCOM P123	193
MiCOM P127	194
MiCOM P22x	195
MiCOM P220	195
MiCOM P225	196
MiCOM P521	197
MiCOM P92x	198
MiCOM P921 / MiCOM P922 / MiCOM P923	198

MiCOM P111

Ready-to-use configuration

Number of identical MiCOM configurations ordered

This order form can be used to define a complete MiCOM configuration. Check the boxes that match your choices.

■ Please indicate the Catalogue No. (for example: **REL10010**) to your Schneider Electric correspondent. For other variant please contact your Schneider Electric correspondent.

MiCOM P111 ordering variants

Catalog No.	Description	Cortec type (see below)
Model L: No Binary Inputs, 4 Binary Outputs		
REL10000	<input type="checkbox"/> lon = 1A/5A ; 0.01-2 lon Vx = 24-240Vac/250Vdc;	P111L1N0N92N0NN11N
REL10001	<input type="checkbox"/> lon = 1A/5A ; 0.05-12lon Vx = 24-240Vac/250Vdc	P111L1N3N92N0NN11N
Model L: No Binary Inputs, 4 Binary Outputs, RS485 comm. port included		
REL10002	<input type="checkbox"/> lon = 1A/5A ; 0.01-2 lon Vx = 24-240Vac/250Vdc	P111L1N0N92N1NN11N
REL10003	<input type="checkbox"/> lon = 1A/5A ; 0.05-12lon Vx = 24-240Vac/250Vdc	P111L1N3N92N1NN11N
Model N: No Binary Inputs, 6 Binary Outputs		
REL10020	<input type="checkbox"/> lon = 1A/5A ; 0.01-2lon Vx = 24-240Vac/250Vdc	P111N1N0N92N1NN11N
REL10021	<input type="checkbox"/> lon = 1A/5A ; 0.05-12lon Vx = 24-240Vac/250Vdc	P111N1N3N92N1NN11N
Model B: 4 Binary Inputs; 4 Binary Outputs		
REL10040	<input type="checkbox"/> lon = 1A/5A ; 0.01-2 lon Vx = 24-60Vac/Vdc	P111B1N0N91N1NN11N
REL10041	<input type="checkbox"/> lon = 1A/5A ; 0.01-2 lon Vx = 90-240Vac/250Vdc	P111B1N0N92N1NN11N
REL10042	<input type="checkbox"/> lon = 1A/5A ; 0.05-12lon Vx = 24-60Vac/Vdc	P111B1N3N91N1NN11N
REL10043	<input type="checkbox"/> lon = 1A/5A ; 0.05-12lon Vx = 90-240Vac/250Vdc	P111B1N3N92N1NN11N
Model A: 4 Binary Inputs, 8 Binary Outputs		
REL10010	<input type="checkbox"/> lon = 1A/5A ; 0.01-2lon Vx = 24-60Vac/Vdc	P111A1N0N91N1NN11N
REL10011	<input type="checkbox"/> lon = 1A/5A ; 0.01-2lon Vx = 90-240Vac/250Vdc	P111A1N0N92N1NN11N
REL10012	<input type="checkbox"/> lon = 1A/5A ; 0.05-12lon Vx = 24-60Vac/Vdc	P111A1N3N91N1NN11N
REL10013	<input type="checkbox"/> lon = 1A/5A ; 0.05-12lon Vx = 90-240Vac/250Vdc	P111A1N3N92N1NN11N
Model E: 8 Binary Inputs; 6 Binary Outputs		
REL10050	<input type="checkbox"/> lon = 1A/5A ; 0.01-2 lon Vx = 24-60Vac/Vdc	P111E1N0N91N1NN11N
REL10051	<input type="checkbox"/> lon = 1A/5A ; 0.01-2 lon Vx = 90-240Vac/250Vdc	P111E1N0N92N1NN11N
REL10052	<input type="checkbox"/> lon = 1A/5A ; 0.05-12lon Vx = 24-60Vac/Vdc	P111E1N3N91N1NN11N
REL10053	<input type="checkbox"/> lon = 1A/5A ; 0.05-12lon Vx = 90-240Vac/250Vdc	P111E1N3N92N1NN11N
REL10054	<input type="checkbox"/> lon = 1A/5A ; 0.01-12 lon Vx = 24-60Vac/Vdc	P111E1N4N91N1NN11N
REL10055	<input type="checkbox"/> lon = 1A/5A ; 0.01-12 lon Vx = 90-240Vac/250Vdc	P111E1N4N92N1NN11N

4

MiCOM P111

Ready-to-use configuration

(cont.)

MiCOM P111 ordering variants		
Catalog No.	Description	Cortec type (see below)
Accessories for P111		
REL10030	<input type="checkbox"/> Adapter for standard case of P111 to allow mounting the relay on a wall	
REL10031	<input type="checkbox"/> Front cover for Px11 preventing from unauthorised access	

■ Check the corresponding **Cortec code**

Model

L No Binary Inputs, 4 Binary Outputs

N No Binary Inputs, 6 Binary Outputs

B 4 Binary Inputs, 4 Binary Outputs

A 4 Binary Inputs, 8 Binary Outputs

E 8 Binary Inputs, 6 Binary Outputs

Earth current input

0 Ion = 1 A/5A (selectable via HMI); 0.01 – 2 Ion

3 Ion = 1 A/5A (selectable via HMI); 0.05 – 12 Ion

4 **Model E special range:**
Ion = 1 A/5A (selectable via HMI); 0.01 – 12 Ion

Vx Auxiliary Voltage Supply

1 **Model B, A, E:** 24 - 60 Vac/dc

2 **Model B, A, E:** 90 - 240 Vac/250 Vdc

2 **Model L, N:** 24 - 240 Vac/250 Vdc

Communication port / protocol

0 **Model L:** Without USB port and RS485

1 **Model N, B, A, E:** USB port and RS485 with settable switching between Modbus and IEC103 via HMI

1 **Model L:** rear port RS485 with settable switching between Modbus and IEC103 via HMI

Language

1 English/ German/ French/ Spanish/ Russian/ Turkish/ Polish

4

P111

1

N

N

9

N

N

N

1

N

Number of identical MiCOM configurations ordered

This order form can be used to define a complete MiCOM configuration. Check the boxes that match your choices.

■ Please indicate the Catalogue No. (for example: **REL10100**) to your Schneider Electric correspondent. For other variant please contact your Schneider Electric correspondent.

MiCOM P115 ordering variants

Catalog No.	Description	Cortec type (see below)
REL10100 <input type="checkbox"/>	In =1A; 0.2 – 40 In Ion = 1 A; 0.01 – 2 Ion Vx = 60-240Vac/60-250Vdc	P11574611110001
REL10101 <input type="checkbox"/>	In =1A; 0.2 – 40 In Ion = 1 A; 0.01 – 2 Ion Vx = 24-60Vac/dc	P11574611111001
REL10102 <input type="checkbox"/>	In =1A; 0.2 – 40 In Ion = 1 A; 0.05 – 10 Ion Vx = 60-240Vac/60-250Vdc	P11574611110101
REL10103 <input type="checkbox"/>	In =1A; 0.2 – 40 In Ion = 1 A; 0.05 – 10 Ion Vx = 24-60Vac/dc	P11574611111101
REL10104 <input type="checkbox"/>	In =5A; 0.2 – 40 In Ion = 5 A; 0.01 – 2 Ion Vx = 60-240Vac/60-250Vdc	P11574611110311
REL10105 <input type="checkbox"/>	In =5A; 0.2 – 40 In Ion = 5 A; 0.01 – 2 Ion Vx = 24-60Vac/dc	P11574611111311
REL10106 <input type="checkbox"/>	In = 5A ; 0.05-10 Ion Ion = 5 A; 0.05 – 10 Ion Vx = 60-240Vac/60-250Vdc	P11574611110411
REL10107 <input type="checkbox"/>	In = 5A ; 0.05-10 Ion Ion = 5 A; 0.05 – 10 Ion Vx = 24-60Vac/dc	P11574611111411
REL10108 <input type="checkbox"/>	In = 5A ; 0.05-10 Ion Ion = 5 A; 0.05 – 10 Ion no auxiliary voltage	P11574611112411

4

■ Check the corresponding **Cortec code**

Note
The above ordering variants have:

- flush mounting case
- dual powering (CTs and auxiliary voltage Vx)
- language set: English/ German/Polish/French/ Spanish
- energy output for sensitive CB coil/striker: 12-24Vdc/0.1J or MiTOP

Supply mode: dual powering (CTs and auxiliary voltage Vx) or single powering (CTs only)

- 0 Vx=60-240Vac/60-250Vdc
- 1 Vx=24-60Vac/dc
- 2 Self powering: no auxiliary voltage

Earth current input

- 0 Ion = 1 A; 0.01 – 2 Ion
- 1 Ion = 1 A; 0.05 – 10 Ion
- 3 Ion = 5 A; 0.01 – 2 Ion
- 4 Ion = 5 A; 0.05 – 10 Ion

Phase current inputs

- 0 In=1A; 0.2 – 40 In
- 1 In=5A; 0.2 – 40 In

Language

- 1 English/ German/ French/ Spanish/ Polish

P115

Number of identical MiCOM configurations ordered

This order form can be used to define a complete MiCOM configuration.

Check the boxes that match your choices.

■ Please indicate the Catalogue No. (for example: **REL10200**) to your Schneider Electric correspondent.
For other variant please contact your Schneider Electric correspondent.

MiCOM P116 ordering variants

Catalog No.	Description	Cortec type (see below)
Model A: Standard variant - Flush mounted		
REL10200	<input type="checkbox"/> In=1A; 0.1 – 40 In Ion = 1 A; 0.002 – 1 Ion Vx=60-240Vac/60-250Vdc	P116A1N1N15115111N
REL10201	<input type="checkbox"/> In=1A; 0.1 – 40 In Ion = 1 A; 0.002 – 1 Ion Vx=24-60Vac/dc	P116A1N1N14115111N
REL10202	<input type="checkbox"/> In=1A; 0.1 – 40 In Ion = 1 A; 0.01 – 8 Ion Vx=60-240Vac/60-250Vdc	P116A1N2N15115111N
REL10203	<input type="checkbox"/> In=1A; 0.1 – 40 In Ion = 1 A; 0.01 – 8 Ion Vx=24-60Vac/dc	P116A1N2N14115111N
REL10204	<input type="checkbox"/> In=5A; 0.1 – 40 In Ion = 5 A; 0.01 – 8 Ion Vx=60-240Vac/60-250Vdc	P116A1N5N25115111N
REL10205	<input type="checkbox"/> In=5A; 0.1 – 40 In Ion = 5 A; 0.01 – 8 Ion Vx=24-60Vac/dc	P116A1N5N24115111N
REL10206	<input type="checkbox"/> In=1A; 0.1 – 40 In Ion = 1 A; 0.10 – 40 Ion Vx=24-60Vac/dc	P116A1N3N14111111N
REL10207	<input type="checkbox"/> In=1A; 0.1 – 40 In Ion = 1 A; 0.01 – 8 Ion Vx=60-240Vac/60-250Vdc	P116A1N2N15111111N
REL10208	<input type="checkbox"/> In=5A; 0.1 – 40 In Ion = 5 A; 0.01 – 8 Ion Vx=60-240Vac/60-250Vdc	P116A1N5N25111111N
Model A: Standard variant - Withdrawable solution		
REL10210	<input type="checkbox"/> In=1A; 0.1 – 40 In Ion = 1 A; 0.002 – 1 Ion Vx=60-240Vac/60-250Vdc	P116A1N1N15115111W
REL10211	<input type="checkbox"/> In=1A; 0.1 – 40 In Ion = 1A; 0.002 – 1 Ion Vx=24-60Vac/dc	P116A1N1N14115111W
REL10212	<input type="checkbox"/> In=1A; 0.1 – 40 In Ion = 1 A; 0.01 – 8 Ion Vx=60-240Vac/60-250Vdc	P116A1N2N15115111W
REL10213	<input type="checkbox"/> In=1A; 0.1 – 40 In Ion = 1 A; 0.01 – 8 Ion Vx=24-60Vac/dc	P116A1N2N14115111W
REL10214	<input type="checkbox"/> In=5A; 0.1 – 40 In Ion = 5 A; 0.01 – 8 Ion Vx=60-240Vac/60-250Vdc	P116A1N5N25115111W
REL10215	<input type="checkbox"/> In=5A; 0.1 – 40 In Ion = 5 A; 0.01 – 8 Ion Vx=24-60Vac/dc	P116A1N5N24115111W
REL10216	<input type="checkbox"/> In=1A; 0.1 – 40 In Ion = 1 A; 0.002 – 1 Ion Vx=60-240Vac/60-250Vdc	P116A1N1N15111111W
Model L: Without auxiliary voltage - Flush mounted		
REL10300	<input type="checkbox"/> In=1A; 0.1 – 40 In Ion = 1 A; 0.002 – 1 Ion Vx= no auxiliary voltage	P116L1N1N13NN1111N
REL10301	<input type="checkbox"/> In=1A; 0.1 – 40 In Ion = 1 A; 0.01 – 8 Ion Vx= no auxiliary voltage	P116L1N2N13NN1111N
REL10302	<input type="checkbox"/> In=1A; 0.1 – 40 In Ion = 1 A; 0.1 – 40 Ion Vx= no auxiliary voltage	P116L1N3N13NN1111N
REL10303	<input type="checkbox"/> In=5A; 0.1 – 40 In Ion = 1 A; 0.002 – 1 Ion Vx= no auxiliary voltage	P116L1N1N23NN1111N
REL10304	<input type="checkbox"/> In=5A; 0.1 – 40 In Ion = 1 A; 0.01 – 8 Ion Vx= no auxiliary voltage	P116L1N2N23NN1111N
REL10305	<input type="checkbox"/> In=5A; 0.1 – 40 In Ion = 5 A; 0.01 – 8 Ion Vx= no auxiliary voltage	P116L1N5N23NN1111N
REL10306	<input type="checkbox"/> In=5A; 0.1 – 40 In Ion = 5 A; 0.1 – 40 Ion Vx= no auxiliary voltage	P116L1N6N23NN1111N
REL10307	<input type="checkbox"/> In=5A; 0.1 – 40 In Ion = 5 A; 0.002 – 1 Ion Vx= no auxiliary voltage	P116L1N4N23NN1111N
Model L: Without auxiliary voltage - Withdrawable solution		
REL10310	<input type="checkbox"/> In=1A; 0.1 – 40 In Ion = 1 A; 0.002 – 1 Ion Vx= no auxiliary voltage	P116L1N1N13NN1111W
REL10311	<input type="checkbox"/> In=1A; 0.1 – 40 In Ion = 1A; 0,01 - 8 Ion Vx= no auxiliary voltage	P116L1N2N13NN1111W
REL10312	<input type="checkbox"/> In=1A; 0.1 – 40 In Ion = 1 A; 0.1 – 40 Ion IVx= no auxiliary voltage	P116L1N3N13NN1111W
REL10313	<input type="checkbox"/> In=5A; 0.1 – 40 In Ion = 1 A; 0.002 – 1 Ion Vx= no auxiliary voltage	P116L1N1N23NN1111W
REL10314	<input type="checkbox"/> In=5A; 0.1 – 40 In Ion = 1 A; 0.01 – 8 Ion Vx= no auxiliary voltage	P116L1N2N23NN1111W
REL10315	<input type="checkbox"/> In=5A; 0.1 – 40 In Ion = 5 A; 0.01 – 8 Ion Vx= no auxiliary voltage	P116L1N5N23NN1111W
REL10316	<input type="checkbox"/> In=5A; 0.1 – 40 In Ion = 5A; 0,1 - 40 Ion Vx= no auxiliary voltage	P116L1N6N23NN1111W
REL10317	<input type="checkbox"/> In=5A; 0.1 – 40 In Ion = 5 A; 0.002 – 1 Ion Vx= no auxiliary voltage	P116L1N4N23NN1111W

4

■ Check the corresponding
Cortec code
P116 Model A

Note

The above ordering variants are for Model A equipped with:

- 1 or 5 electro-magnetic flags
- RS485 with settable switching between Modbus or IEC103 in HMI
- Universal binary inputs: 24-240Vac or 24-250Vdc
- Language: English/German/French/Spanish/Portuguese/Russian/Turkish

Earth current input

- 1 I_{on} = 1 A; 0.002 – 1 I_{on}
- 2 I_{on} = 1 A; 0.01 – 8 I_{on}
- 3 I_{on} = 1 A; 0.10 – 40 I_{on}
- 5 I_{on} = 5 A; 0.01 – 8 I_{on}

Phase current inputs

- 1 I_n=1A; 0.1 – 40 I_n
- 2 I_n=5A; 0.1 – 40 I_n

**Auxiliary supply
Dual Powered (CT and Vx Auxiliary Voltage)**

- 4 V_x=24-60Vac/dc
- 5 V_x=60-240Vac/60-250Vdc

Electro magnetic flags on the front panel

- 1 One trip flag indicator
- 5 Four additional electro magnetic flags

Case (Mounting solution)

- W Basic flush mounting case with the cassette for withdrawable solution
- N Basic flush mounting case

P116 A 1 N N 1 1 1 1 1

■ Check the corresponding
Cortec code
P116 Model L

Note

The above ordering variants are for Model L equipped with:

- 2 binary outputs
- 1 electro magnetic flag
- no communication
- no binary inputs
- Language: English/German/French/Spanish/Portuguese/Russian/Turkish

Earth current input

- 1 I_{on} = 1 A; 0.002 – 1 I_{on}
- 2 I_{on} = 1 A; 0.01 – 8 I_{on}
- 3 I_{on} = 1 A; 0.10 – 40 I_{on}
- 4 I_{on} = 5 A; 0,002 - 1 I_{on}
- 5 I_{on} = 5 A; 0.01 – 8 I_{on}
- 6 I_{on} = 5 A; 0.1 – 40 I_{on}

Phase current inputs

- 1 I_n=1A; 0.1 – 40 I_n
- 2 I_n=5A; 0.1 – 40 I_n

Case (Mounting solution)

- W Basic flush mounting case with the cassette for withdrawable solution
- N Basic flush mounting case

P116 L 1 N N 3 N N 1 1 1 1

Number of identical MiCOM configurations ordered

This order form can be used to define a complete MiCOM configuration.

Check the boxes that match your choices.

■ Please indicate the Catalogue No. (for example: **REL21202**) to your Schneider Electric correspondent. For other variant please contact your Schneider Electric correspondent.

MiCOM P122 ordering variants					
Catalog No.	Description	Cortec type (see below)			
REL21201	<input type="checkbox"/> Ion = 1A; 0,1 - 40 Ion	Vx = 24-250 Vdc / 48-240 Vac	Modbus	P122A00Z112CE0	
REL21202	<input type="checkbox"/> Ion = 1A; 0,01 - 8 Ion	Vx = 24-250 Vdc / 48-240 Vac	Modbus	P122B00Z112CE0	
REL21203	<input type="checkbox"/> Ion = 1A; 0,01 - 8 Ion	Vx = 24-250 Vdc / 48-240 Vac	IEC 60870-5-103	P122B00Z312CE0	

MiCOM P123 ordering variants					
Catalog No.	Description	Cortec type (see below)			
REL21301	<input type="checkbox"/> Ion = 1A; 0,1 - 40 Ion	Vx = 24-250 Vdc / 48-240 Vac	Modbus	P123A00Z112CE0	
REL21302	<input type="checkbox"/> Ion = 1A; 0,01 - 8 Ion	Vx = 24-250 Vdc / 48-240 Vac	Modbus	P123B00Z112CE0	
REL21303	<input type="checkbox"/> Ion = 1A; 0,01 - 8 Ion	Vx = 24-250 Vdc / 48-240 Vac	IEC 60870-5-103	P123B00Z312CE0	

■ Check the corresponding **Cortec code**

Model

2 MiCOM P122

3 MiCOM P123

Earth current input

A Ion = 1A; 0,1 - 40 Ion

B Ion = 1 A; 0.01 - 8 Ion

Voltage inputs

0 None

Optional features

0 None

Communication protocol

1 Modbus

3 IEC 60870-5-103

Language

1 English (*)

P12

0

0

Z

1

2

C

E

0

*** Working language**

The following languages can be settable from the keypad:

- French/English/Spanish/Portuguese/Turkish/Polish/Russian/Chinese/Dutch/German/Italian/Czech/Hungarian/Greek



MiCOM P127

Ready-to-use configuration

Number of identical MiCOM configurations ordered

This order form can be used to define a complete MiCOM configuration. Check the boxes that match your choices.

■ Please indicate the Catalogue No. (for example: **REL21702** to your Schneider Electric correspondent. For other variant please contact your Schneider Electric correspondent.

MiCOM P127 ordering variants					
Catalog No.	Description	Cortec type (see below)			
REL21701	<input type="checkbox"/> Ion = 1A; 0,1 - 40 Ion	Vx = 24-250 Vdc / 48-240 Vac	Modbus	P127AA0Z112FB0	
REL21702	<input type="checkbox"/> Ion = 1A; 0,01 - 8 Ion	Vx = 24-250 Vdc / 48-240 Vac	Modbus	P127BA0Z112FB0	
REL21703	<input type="checkbox"/> Ion = 1A; 0,01 - 8 Ion	Vx = 24-250 Vdc / 48-240 Vac	IEC 60870-5-103	P127BA0Z312FB0	
Additional 5 digital inputs					
REL21704	<input type="checkbox"/> Ion = 1A; 0,01 - 8 Ion	Vx = 24-250 Vdc / 48-240 Vac	Modbus	P127BA1Z112FB0	
REL21705	<input type="checkbox"/> Ion = 1A; 0,1 - 40 Ion	Vx = 24-250 Vdc / 48-240 Vac	IEC 60870-5-103	P127BA1Z312FB0	
Irig B inputs + additional 2nd rear port					
REL21706	<input type="checkbox"/> Ion = 1A; 0,01 - 8 Ion	Vx = 24-250 Vdc / 48-240 Vac	Modbus	P127BA2Z112FB0	
REL21707	<input type="checkbox"/> Ion = 1A; 0,01 - 8 Ion	Vx = 24-250 Vdc / 48-240 Vac	IEC 60870-5-103	P127BA2Z312FB0	

4

■ Check the corresponding **Cortec code**

	Earth current input
	A <input type="checkbox"/> Ion = 1A; 0,1 - 40 Ion
	B <input type="checkbox"/> Ion = 1 A; 0.01 – 8 Ion
	Voltage inputs
	A <input checked="" type="checkbox"/> 57-130 V
	Optional features
	0 <input type="checkbox"/> None
	1 <input type="checkbox"/> Additional 5 digital inputs
	2 <input type="checkbox"/> Irig B inputs + addit. 2nd rear port
	Communication protocol
1 <input type="checkbox"/> Modbus/Modbus (if addit. 2nd rear port)	
3 <input type="checkbox"/> IEC60870-5-103/Modbus (if addit. 2nd rear port)	
Language	
1 <input checked="" type="checkbox"/> English (*)	

P127	<input type="checkbox"/>	A	<input type="checkbox"/>	Z	<input type="checkbox"/>	1	2	F	B	O
------	--------------------------	---	--------------------------	---	--------------------------	---	---	---	---	---

*** Working language**

The following languages can be settable from the keypad:

- French/English/Spanish/Portuguese/Turkish/Polish/Russian/Chinese/Dutch/German/Italian/Czech/Hungarian/Greek

Number of identical MiCOM configurations ordered

This order form can be used to define a complete MiCOM configuration. Check the boxes that match your choices.

■ Please indicate the Catalogue No. (for example: **REL22003**) to your Schneider Electric correspondent. For other variant please contact your Schneider Electric correspondent.

MiCOM P220 ordering variants					
Catalog No.	Description	Cortec type (see below)			
REL22001	<input type="checkbox"/> Ion = 1A; 0,002 to 1 Ion	Vx = 24-250 Vdc / 48-240 Vac	Modbus	P220C00Z11200BA	
REL22003	<input type="checkbox"/> Ion = 1A; 0,002 to 1 Ion	Vx = 24-250 Vdc / 48-240 Vac	IEC60870-5-103	P220C00Z31200BA	
6 RTDs Monitoring					
REL22002	<input type="checkbox"/> Ion = 1A; 0,002 to 1 Ion	Vx = 24-250 Vdc / 48-240 Vac	Modbus	P220C00Z112A0BA	
REL22004	<input type="checkbox"/> Ion = 1A; 0,002 to 1 Ion	Vx = 24-250 Vdc / 48-240 Vac	IEC60870-5-103	P220C00Z312A0BA	

■ Check the corresponding **Cortec code**

Earth current input

C 0,002 to 1 Ion

Voltage inputs

0 None

Communication protocol

1 Modbus

3 IEC 60870-5-103

Optional temperature monitoring

0 None

A 6 RTDs monitoring

Language

1 English (*)

P220 C 0 0 Z 1 2 0 B A

*** Working language**

The following languages can be settable from the keypad:

- French/English/Spanish/Portuguese/Turkish/Polish/Russian/Chinese/Dutch/German/Italian/Czech/Hungarian/Greek



MiCOM P225

Ready-to-use configuration

Number of identical MiCOM configurations ordered

This order form can be used to define a complete MiCOM configuration. Check the boxes that match your choices.

■ Please indicate the Catalogue No. (for example: **REL22502**) to your Schneider Electric correspondent. For other variant please contact your Schneider Electric correspondent.

MiCOM P225 ordering variants						
Catalog No.		Description				Cortec type (see below)
REL22501	<input type="checkbox"/>	Ion = 1A; 0,002 to 1 Ion	Vx = 24-250 Vdc / 48-240 Vac	Modbus		P225CA0Z11200BA
REL22503	<input type="checkbox"/>	Ion = 1A; 0,002 to 1 Ion	Vx = 24-250 Vdc / 48-240 Vac	IEC60870-5-103		P225CA0Z31200BA
10 RTDs Monitoring						
REL22502	<input type="checkbox"/>	Ion = 1A; 0,002 to 1 Ion	Vx = 24-250 Vdc / 48-240 Vac	Modbus		P225CA0Z112A0BA
REL22504	<input type="checkbox"/>	Ion = 1A; 0,002 to 1 Ion	Vx = 24-250 Vdc / 48-240 Vac	IEC60870-5-103		P225CA0Z312A0BA

■ Check the corresponding **Cortec code**

4

Earth current input

C 0,002 to 1 Ion

Voltage inputs

A 57-130 V

Communication protocol

1 Modbus/Modbus

3 IEC 60870-5-103/modbus

Optional temperature monitoring

0 None

A 10 RTDs monitoring

Language

1 English (*)

P225 C A 0 Z 1 2 0 B A

*** Working language**

The following languages can be settable from the keypad:

- French/English/Spanish/Portuguese/Turkish/Polish/Russian/Chinese/Dutch/German/Italian/Czech/Hungarian/Greek

Number of identical MiCOM configurations ordered

This order form can be used to define a complete MiCOM configuration. Check the boxes that match your choices.

■ Please indicate the Catalogue No. (for example: **REL25103**) to your Schneider Electric correspondent. For other variant please contact your Schneider Electric correspondent.

MiCOM P521 ordering variants					
Catalog No.	Description	Cortec type (see below)			
Protection communication: EIA (RS) 485 single channel					
REL25101	<input type="checkbox"/> Ion = 1A; 0,01 to 8 Ion	Vx = 24-250 Vdc / 48-240 Vac	Modbus	P521B0BZ112DA0	
REL25102	<input type="checkbox"/> Ion = 1A; 0,01 to 8 Ion	Vx = 24-250 Vdc / 48-240 Vac	IEC60870-5-103	P521B0BZ312DA0	
Protection communication: 1300 nm single mode/single channel					
REL25103	<input type="checkbox"/> Ion = 1A; 0,01 to 8 Ion	Vx = 24-250 Vdc / 48-240 Vac	Modbus	P521B0GZ112DA0	
REL25104	<input type="checkbox"/> Ion = 1A; 0,01 to 8 Ion	Vx = 24-250 Vdc / 48-240 Vac	IEC60870-5-103	P521B0GZ312DA0	

■ Check the corresponding **Cortec code**

P521	B	0		Z		1	2	D	A	0
------	---	---	--	---	--	---	---	---	---	---

Protection communication

B EIA (RS) 485 single channel

G 1300 nm single mode / single channel

Communication protocol

1 Modbus

3 IEC 60870-5-103

Language

1 English (*)

*** Working language**

The following languages can be settable from the keypad:

- French/English/Spanish/Portuguese/Turkish/Polish/Russian/Chinese/Dutch/German/Italian/Czech/Hungarian/Greek

MiCOM P921 - P922 - P923

Ready-to-use configuration

Number of identical MiCOM configurations ordered

This order form can be used to define a complete MiCOM configuration. Check the boxes that match your choices.

■ Please indicate the Catalogue No. (for example: **REL29101**) to your Schneider Electric correspondent. For other variant please contact your Schneider Electric correspondent.

MiCOM P92x ordering variants					
Catalog No.	Description	Cortec type (see below)			
Model 1: P921 voltage relay					
REL29101	<input type="checkbox"/> Vrange = 57-130 V	Vx = 24-250 Vdc / 48-240 Vac	Modbus	P9210ASZ112CC0	
REL29102	<input type="checkbox"/> Vrange = 57-130 V	Vx = 24-250 Vdc / 48-240 Vac	IEC60870-5-103	P9210ASZ312CC0	
Model 2: P922 voltage / frequency relay					
REL29201	<input type="checkbox"/> Vrange = 57-130 V	Vx = 24-250 Vdc / 48-240 Vac	Modbus	P9220ASZ112CC0	
REL29202	<input type="checkbox"/> Vrange = 57-130 V	Vx = 24-250 Vdc / 48-240 Vac	IEC60870-5-103	P9220ASZ312CC0	
Model 3: P923 voltage / frequency relay with (df / dt) relay					
REL29301	<input type="checkbox"/> Vrange = 57-130 V	Vx = 24-250 Vdc / 48-240 Vac	Modbus	P9230ASZ112CC0	
REL29302	<input type="checkbox"/> Vrange = 57-130 V	Vx = 24-250 Vdc / 48-240 Vac	IEC60870-5-103	P9230ASZ312CC0	

4

■ Check the corresponding **Cortec code**

P92	<input type="checkbox"/>	O	A	S	Z	<input type="checkbox"/>	1	2	C	C	0
-----	--------------------------	---	---	---	---	--------------------------	---	---	---	---	---

Model

1 P921 voltage relay

2 P922 voltage / frequency relay

3 P923 voltage / frequency relay with (df / dt) relay

Voltage input

A 57-130 V

Auxiliary voltage

Z 24-250 Vdc / 48-240 Vac

Communication protocol

1 Modbus

3 IEC 60870-5-103

Language

1 English (*)

*** Working language**

The following languages can be settable from the keypad:

- French/English/Spanish/Portuguese/Turkish/Polish/Russian/Chinese/Dutch/German/Italian/Czech/Hungarian/Greek

Schneider Electric Industries SAS

35, rue Joseph Monier
CS 30323
F - 92506 Reuil Malmaison Cedex (France)
Tel.: +33 (0) 1 41 29 70 00
RCS Nanterre 954 503 439
Capital social 896 313 776 €
www.schneider-electric.com

As standards, specifications and designs change from time to time, please ask for confirmation of the information given in this publication.

Design: Schneider Electric - Sonovision
Photos: Schneider Electric and ©iStockphoto
Printed:



*This document has been
printed on recycled paper.*

Schneider Electric

35, rue Joseph Monier
CS 30323
F - 92506 Rueil Malmaison Cedex (France)
Tel.: +33 (0) 1 41 29 70 00
RCS Nanterre 954 503 439
Capital social 928 298 512 €
www.schneider-electric.com

As standards, specifications and designs change from time to time, please ask for confirmation of the information given in this publication.

Design: Schneider Electric
Photos: Schneider Electric and ©iStockphoto



*This document has been
printed on recycled paper.*